

Data Sheet

Strainer housing
Type **FIA**

Reliable filtration upto 65 bar



FIA strainers are a range of angleway and straightway strainers, which are carefully designed to give favourable flow conditions. The design makes the strainer easy to install, and ensures quick strainer inspection and cleaning.

FIA strainers are used ahead of automatic controls, pumps, compressors etc., for initial plant start-up and where permanent filtration of the refrigerant is required. The strainer reduces the risk of undesirable system breakdowns and reduces wear and tear on plant components.

FIA strainers are equipped with a screen mesh of stainless steel, available in sizes 100, 150, 250 and 500 μ (microns*), (US 150, 100, 72, 38 mesh*).

* Mesh is the number of threads per inch. μ (microns) is the distance between two threads ($1\mu = 1/1000$ mm).

Features

- Modular Concept:
 - Each valve housing is available with DIN and ANSI butt weld connection and in several different sizes.
 - Possible to convert FIA strainers to any other product in the SVL family (Shut-off valve, regulating valve, check & stop valve or check valve) just by replacing the complete top part.
- Quick and easy maintenance. Replacement of top part does not require welding.
- Filter net of stainless steel mounted direct without extra gaskets means easy servicing.
- Two types of strainer inserts are available:
 - A plain insert made of stainless steel.
 - A pleated insert (DN 15-200) with extra large surface, which ensures long intervals between cleaning and low pressure drop.
- FIA 15-40 (½ – 1 ½ in.):
A special insert (50µ) can be used in combination with a standard version when cleaning a plant during commissioning.
- FIA 50-200 (2 - 8 in.):
A large capacity filter bag (50µ) can be inserted for cleaning plant during commissioning.
- FIA 65-200 (2½ - 8 in.) can be equipped with a magnetic insert for detention of iron particles and other magnetic particles.
- Each strainer clearly marked with type, size and performance range
- Housing and bonnet of low temperature steel in accordance with the requirements of the Pressure Equipment Directive and those of other international classification authorities
- Classification: DNV, CRN, BV, EAC etc. To get an updated list of certification on the products please contact your local Danfoss Sales Company.
- Equipped with 42CrMo5 bolts to withstand high pressure.

Media

Refrigerants

Applicable to HCFC, HFC, R717 (Ammonia), R744 (CO₂) and flammable refrigerants.

For further information refer to the product instruction for FIA.

New refrigerants

Danfoss products are continually evaluated for use with new refrigerants depending on market requirements.

When a refrigerant is approved for use by Danfoss, it is added to the relevant portfolio, and the R number of the refrigerant (e.g. R513A) will be added to the technical data of the code number. Therefore, products for specific refrigerants are best checked at store.danfoss.com/en/, or by contacting your local Danfoss representative.

Product specification

Pressure and temperature data

Table 1: Temperature and pressure

Description	Values
Temperature range	-60 °C /+150 °C (-76 °F /+302 °F)
Max working pressure	65 bar (943 psig)

Connections

Figure 1: DIN

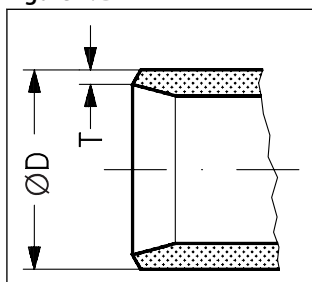

Table 2: Butt-weld DIN (EN 10220)

Size		ØD	T	ØD	T	k _v -angle	k _v -straight	C _v -angle	C _v -straight
mm	in.	mm	mm	in.	in.	m ³ /h	m ³ /h	US _{gal} /min	US _{gal} /min
6	¼	13.5	2.3	0.531	0.091	2.9	2.0	3.4	2.4
10	¾	17.2	2.3	0.677	0.091	4.5	3.2	5.2	3.6
15	½	21.3	2.3	0.839	0.091	7.0	4.9	8.1	5.7
20	¾	26.9	2.3	1.059	0.091	14.6	10.2	16.9	11.8
25	1	33.7	2.6	1.327	0.103	24.8	17.4	28.8	20.2
32	1¼	42.4	2.6	1.669	0.102	42.6	29.8	49.4	34.6
40	1½	48.3	2.6	1.902	0.103	45.2	31.6	52.4	36.7
50	2	60.3	2.9	2.37	0.11	80	65	93	76
65	2½	76.1	2.9	3	0.11	120	97	140	113
80	3	88.9	3.2	3.50	0.13	182	152	211	176
100	4	114.3	3.6	4.50	0.14	313	278	363	323
125	5	139.7	4.0	5.50	0.16	514	470	596	545
150	6	168.3	4.5	6.63	0.18	785	597	911	693
200	8	219.1	6.3	8.63	0.25	1168	1024	1355	1188

Figure 2: ANSI

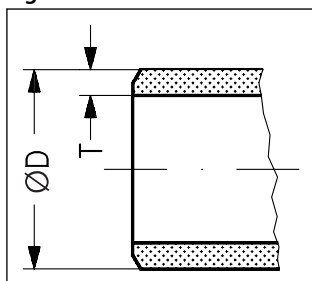

Table 3: Butt-weld ANSI (B 36.10 Schedule 80)

Size		ØD	T	ØD	T	k _v -angle	k _v -straight	C _v -angle	C _v -straight
mm	in.	mm	mm	in.	in.	m ³ /h	m ³ /h	US _{gal} /min	US _{gal} /min
6	¼	13.5	3.0	0.531	0.118	2.9	2.03	3.4	2.4
10	¾	17.2	3.2	0.677	0.126	4.5	3.15	5.2	3.6
15	½	21.3	3.7	0.839	0.146	7.0	4.9	8.1	5.7
20	¾	26.9	4.0	1.059	0.158	14.6	10.2	16.9	11.8

Strainer housing, type FIA

Size		ØD	T	ØD	T	k _{v-angle}	k _{v-straight}	C _{v-angle}	C _{v-straight}
mm	in.	mm	mm	in.	in.	m ³ /h	m ³ /h	US _{gal/min}	US _{gal/min}
25	1	33.7	4.6	1.327	0.181	24.8	17.4	28.8	20.2
32	1¼	42.4	4.9	1.669	0.193	42.6	29.8	49.4	34.6
40	1½	48.3	5.1	1.902	0.201	45.2	31.6	52.4	36.7

Table 4: Butt-weld ANSI (B 36.10 Schedule 40)

Size		ØD	T	ØD	T	k _{v-angle}	k _{v-straight}	C _{v-angle}	C _{v-straight}
mm	in.	mm	mm	in.	in.	m ³ /h	m ³ /h	US _{gal/min}	US _{gal/min}
50	2	60.3	3.9	2.37	0.15	80	65	93	76
65	2½	73.0	5.2	2.87	0.20	120	97	140	113
80	3	88.9	5.5	3.50	0.22	182	152	211	176
100	4	114.3	6.0	4.50	0.24	313	278	363	323
125	5	141.3	6.6	5.56	0.26	514	470	596	545
150	6	168.3	7.1	6.63	0.28	785	597	911	693
200	8	219.1	8.2	8.63	0.32	1168	1024	1355	1188

Figure 3: SD (DIN)

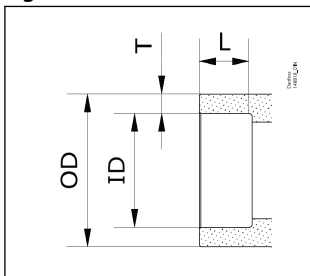

Table 5: Socket-Brazing DIN (EN 1254-5)

Size		ID	L	ØD	T	k _{v-angle}	k _{v-straight}	C _{v-angle}	C _{v-straight}
mm	in.	mm	mm	mm	mm	m ³ /h	m ³ /h	US _{gal/min}	US _{gal/min}
6	¼	6	7.7	12.7	3.35	2.9	2.0	3.4	2.4
10	⅜	10	8	15.88	2.94	4.5	3.2	5.2	3.6
15	½	16	8	21.3	2.65	7.0	4.9	8.1	5.7
20	¾	22	11	26.9	2.45	14.6	10.2	16.9	11.8
25	1	28	11	33.7	2.85	24.8	17.4	28.8	20.2
32	1¼	35	15	42.4	3.7	42.6	29.8	49.4	34.6
40	1½	42	15	48.3	3.15	45.2	31.6	52.4	36.7
50	2	54	13.5	60.3	3.15	80	65	93	76
65	2½	64	13.5	73	4.5	120	97	140	113
80	3	76.1	15	88.9	6.4	182	152	211	176
100	4	108	17.5	118	5	313	278	363	323

Figure 4: SA (ASME)

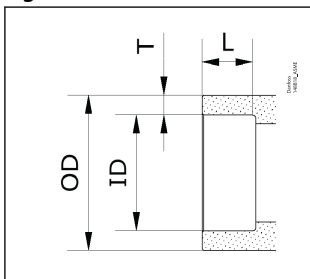

Table 6: Socket-Brazing ASME (ASME B16.50)

Size	ID	L	ØD	T	k _{v-angle}	k _{v-straight}	C _{v-angle}	C _{v-straight}
in.	mm	mm	mm	mm	m ³ /h	m ³ /h	US _{gal/min}	US _{gal/min}
¼	6.35	7.7	12.7	3.18	2.9	2.0	3.4	2.4
⅜	9.53	8	15.88	3.18	4.5	3.2	5.2	3.6
½	15.88	8	21.3	2.71	7.0	4.9	8.1	5.7

Strainer housing, type FIA

Size	ID	L	ØD	T	k _{v-angle}	k _{v-straight}	C _{v-angle}	C _{v-straight}
in.	mm	mm	mm	mm	m ² /h	m ² /h	US gal/min	US gal/min
¾	22.23	11	26.9	2.34	14.6	10.2	16.9	11.8
1½	28.58	11	33.7	2.56	24.8	17.4	28.8	20.2
1¾	34.93	15	42.4	3.74	42.6	29.8	49.4	34.6
1⅝	41.28	15	48.3	3.51	45.2	31.6	52.4	36.7
2½	54	13.5	60.3	3.15	80	65	93	76
2⅝	66.7	13.5	76.1	4.70	120	97	140	113
3¾	79.38	15	88.9	4.76	182	152	211	176
4¾	104.78	17.5	114.3	4.76	313	278	363	323

Design

Strainer Insert

A filter grid and filter net of stainless steel ensure long element life. The filter net offers a very high degree of cleanability.

Housing

The strainer housing is made of special, cold resistant steel.

Installation/Maintenance

The strainer is designed to resist high internal pressures. However, the piping system in general should be designed to avoid liquid traps and reduce the risk of hydraulic pressure caused by thermal expansion.

Install the strainer with the cover in downward position.

Danfoss recommends replacement/cleaning of the strainer when the differential pressure loss >0.5 bar (7.3 psi) in the liquid line and >0.05 bar (0.7 psi) in the suction line. The max. permissible differential pressure is 1 bar (15 psi).

For further information refer to installation instruction for FIA.

Figure 5: Example of marking ring, FIA

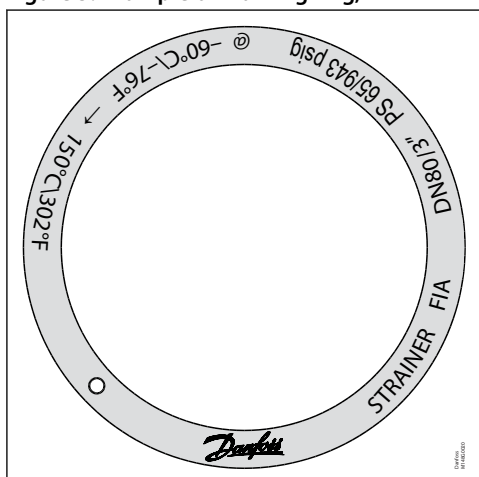

Selection of strainer size

The mesh aperture size of the strainer must satisfy the requirements stated by the suppliers of the equipment to be protected.

The following recommendations of aperture size apply in general to refrigeration installations:

Table 7: All lines

First start up: (Use strainer element with removable insert for FIA DN15-40 or separate filter bag for FIA DN 50-200. 50µ insert should normally be removed after the first 24 hours of operation)	50µ
---	-----

Strainer housing, type FIA

Table 8: Liquid Lines

Ahead of pumps:	500μ [38 mesh]
After pumps:	150μ [100 mesh] / 250μ [72 mesh]
In front of AKVA valves:	100μ [150 mesh]

Table 9: Protection of automatic regulation equipment

Generally	150μ [100 mesh] / 250μ [72 mesh]
Sensitive equipment, e.g. suction regulators with low temperature	250μ [72 mesh]

Table 10: Suction Lines

Ahead of screw compressor	250μ [72 mesh]
Ahead of piston compressor	150μ [100 mesh]

NOTE:

Mesh is the number of threads per inch. μ (microns) is the distance between two threads (1μ = 1 /1000 mm).

Table 11: Flow coefficient (DIN/ANSI)

Connection size (DN)	μ	Mesh	Wire		Free space	Screen area			
			mm	in.		Plain elements		Pleated elements	
FIA					%	cm ²	in ²	cm ²	in ²
15 - 20 (½" - ¾")	100		0.068	0.003	35	25	3.9	45	7.0
	150	100	0.10	0.004	36	25	3.9	45	7.0
	250	72	0.10	0.004	51	25	3.9	45	7.0
	500	38	0.16	0.006	57.6	25	3.9	45	7.0
25 - 40 (1" - 1½")	100		0.068	0.003	35	71	11	160	25.0
	150	100	0.10	0.004	36	71	11	160	25.0
	250	72	0.10	0.004	51	71	11	160	25.0
	500	38	0.16	0.006	57.6	71	11	160	25.0
50 (2")	100		0.068	0.003	35	71	11	200	31.2
	150	100	0.10	0.004	36	87	13.5	200	31.2
	250	72	0.10	0.004	51	87	13.5	200	31.2
	500	38	0.16	0.006	57.6	87	13.5	200	31.2
65 (2½")	150	100	0.10	0.004	36	127	19.7	305	47.6
	250	72	0.10	0.004	51	127	19.7	305	47.6
	500	38	0.16	0.006	57.6	127	19.7	305	47.6
	150	100	0.10	0.004	36	205	31.8	450	70.2
80 (3")	250	72	0.10	0.004	51	205	31.8	450	70.2
	500	38	0.16	0.006	57.6	205	31.8	450	70.2
	150	100	0.10	0.004	36	370	57.4	790	123.2
	250	72	0.10	0.004	51	370	57.4	790	123.2
100 (4")	500	38	0.16	0.006	57.6	370	57.4	790	123.2
	150	100	0.10	0.004	36	510	79.1	1105	172.4
	250	72	0.10	0.004	51	510	79.1	1105	172.4
	500	38	0.16	0.006	57.6	510	79.1	1105	172.4
125 (5")	150	100	0.10	0.004	36	726	112.5	1600	249.6
	250	72	0.10	0.004	51	726	112.5	1600	249.6
	500	38	0.16	0.006	57.6	726	112.5	1600	249.6
	150	100	0.10	0.004	36	1315	203.8	2900	453.1
150 (6")	250	72	0.10	0.004	51	1315	203.8	2900	453.1
	500	38	0.16	0.006	57.6	1315	203.8	2900	453.1
	150	100	0.10	0.004	36	1315	203.8	2900	453.1
	250	72	0.10	0.004	51	1315	203.8	2900	453.1

Table 12: k_v values for FIA angle - plain filter net/pleated filter net

DN	FIA angle - plain filter net				FIA angle - pleated filter net		
	μ100	μ150	μ250	μ500	μ150	μ250	μ500
15	3.3	3.4	3.5	3.7	4.2		
20	6.9	7.1	7.3	7.7	8.8		
25	13.8	14.0	14.5	15.2	17.2	17.9	
32	23.0	23.8	24.7	25.5	29.2	30.5	
40	25.1	25.5	26.4	28.1	31.4	32.6	

Strainer housing, type FIA

DN	FIA angle - plain filter net				FIA angle - pleated filter net		
	μ100	μ150	μ250	μ500	μ150	μ250	μ500
50	45.1	45.9	47.6	50.2	56.7	58.8	62.0
65		56.1	57.8	60.4	69.3	71.4	74.6
80		104.6	108.0	113.1	129.2	133.4	139.7
100		162.4	167.5	176.0	200.6	206.9	217.4
125		275.4	283.9	298.4	340.2	350.7	368.6
150		362.1	373.2	391.9	447.3	462.9	
200		572.9	590.8	620.5	704.9	730.0	

Table 13: k_v values for FIA straight - plain filter net/pleated filter net

DN	FIA straight - plain filter net				FIA straight - pleated filter net		
	μ100	μ150	μ250	μ500	μ150	μ250	μ500
15	2.5	2.6	2.7	2.8	3.3		
20	5.3	5.4	5.6	5.9	6.9		
25	10.5	10.7	11.1	11.6	13.8	14.5	
32	17.6	18.2	18.9	19.5	23.9	24.7	
40	19.2	19.5	20.2	21.5	25.5	26.4	
50	34.5	35.1	36.4	38.4	45.9	47.6	50.2
65		42.9	44.2	46.2	56.1	57.8	60.4
80		80.0	82.6	86.5	104.6	108.0	113.1
100		124.2	128.1	134.6	162.4	167.5	176.0
125		210.6	217.1	228.2	275.4	283.9	298.4
150		276.9	285.4	299.7	362.1	374.0	
200		438.1	451.8	474.5	570.8	587.3	

Material specification

Figure 6: FIA 15 - 40 (½ in. - 1 ½ in.)

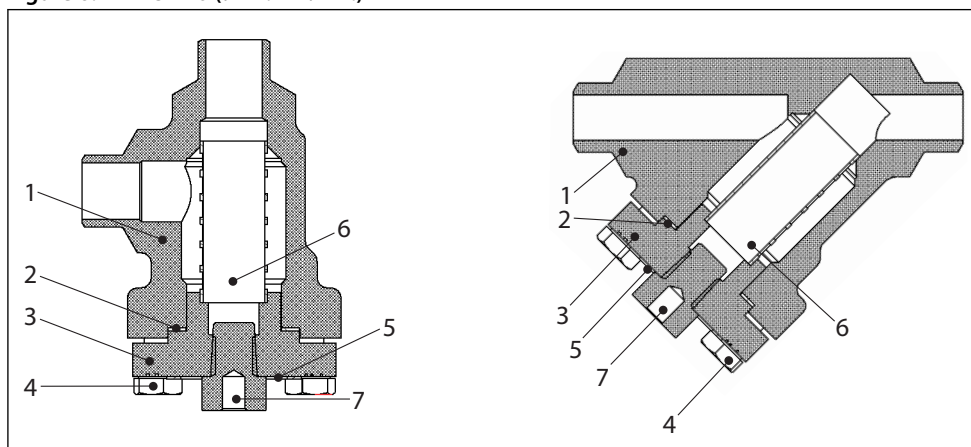

Table 14: FIA 15 - 40 (½ in. - 1 ½ in.)

No.	Part	Material	DIN	ISO	ASTM
1	Housing	Steel	G20Mn5QT, 10213-3 P285QH+QT, 10222-4		LCC, A352 LF2, A350
2	Gasket	Fibre, Non-asbestos			
3	Cover	Steel	P285QH EN10222-4 P275NL1 or 2 EN10028-3		LF2, A350 A, A662
4	Bolts	Stainless steel	A2-70	A2-70	Type 308
5	Marking label	Aluminium			
6	Strainer insert	Stainless steel			
7	Pressure relief screw NPT ¼"	Stainless steel			

Strainer housing, type FIA

Figure 7: FIA 50 - 200 (2 in. - 8 in.)

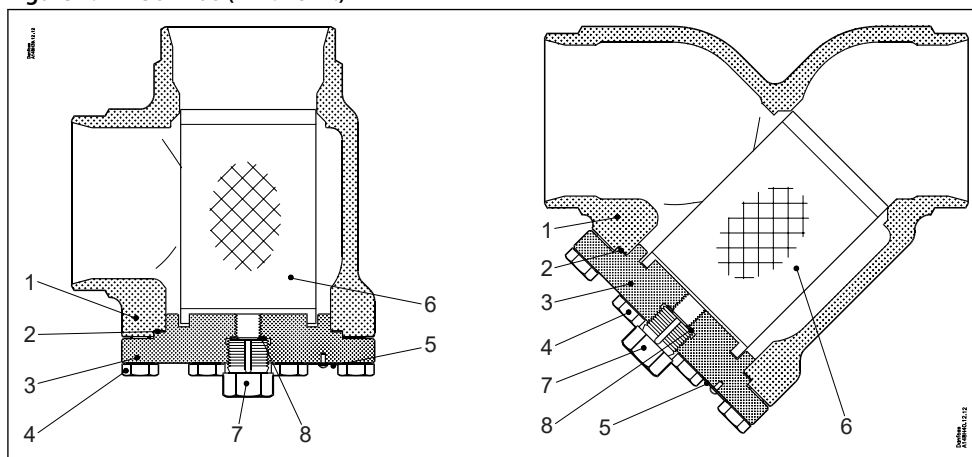

Table 15: FIA 50 - 200 (2 in. - 8 in.)

No.	Part	Material	DIN	ISO	ASTM
1	Housing	Steel	G20Mn5QT, 10213-3 P285QH+QT, 10222-4		LCC, A352 LF2, A350
2	Gasket	Fibre, Non-asbestos			
3	Cover	Steel	P285QH EN10222-4 P275NL1 or 2 EN10028-3		LF2, A350 A, A662
4	Bolts	Stainless steel	A2-70	A2-70	Type 308
5	Marking label	Aluminium			
6	Strainer insert	Stainless steel			
7	Pressure relief screw G $\frac{1}{2}$ "	Stainless steel			
8 ⁽¹⁾	Packing washer	Aluminium			

⁽¹⁾ pos 8 used in FIA 50-200

Dimensions and weights

Figure 8: FIA 15 - 65 Angleway/Straightway dimensions

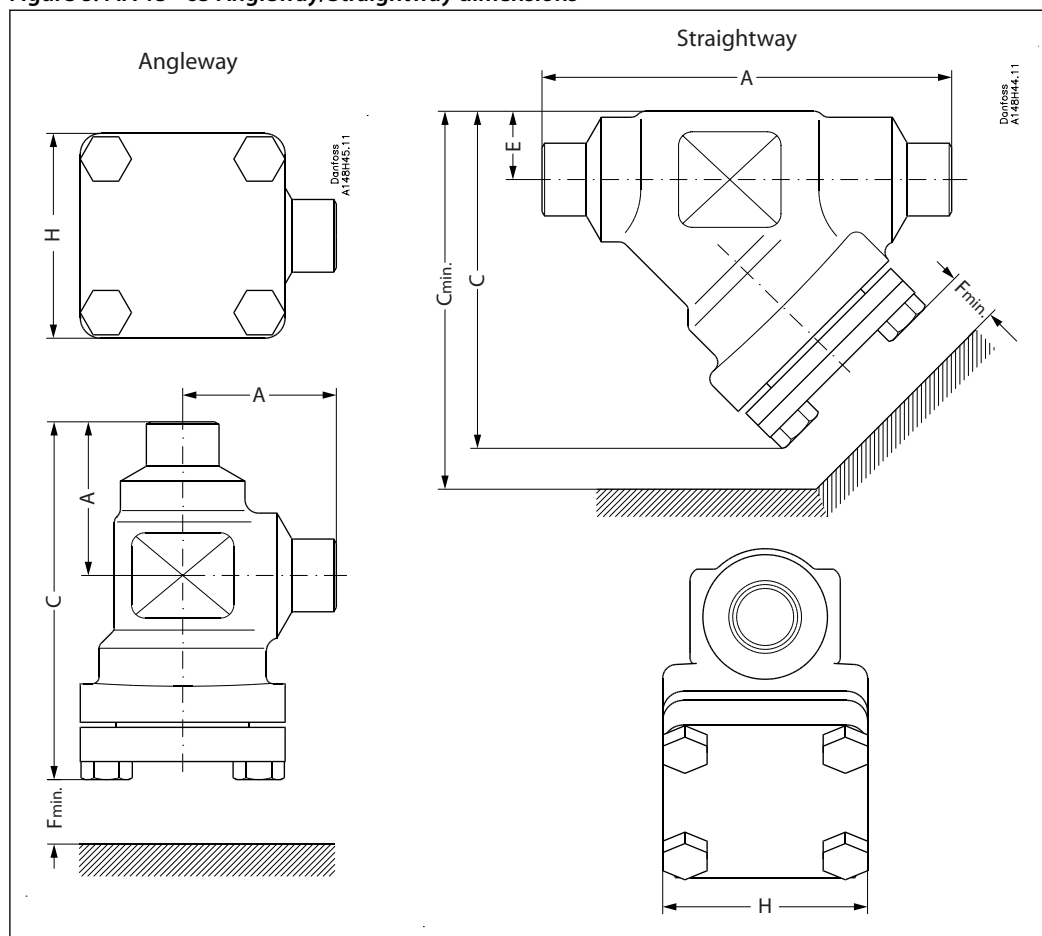

Table 16: Angleway

Strainer size		A	C	H	F _{min.}	Weight
FIA 15-20 (½" - ¾")	mm	45	105	60	68	1.1 kg
	in.	1.77	4.13	2.36	2.68	2.4 lbs
FIA 25-40 (1" - 1½")	mm	55	132	70	95	1.7 kg
	in.	2.17	5.20	2.76	3.74	3.7 lbs
FIA 50 (2")	mm	60	132	77	92	2.8 kg
	in.	2.36	5.20	3.03	3.62	6.2 lbs
FIA 65 (2½")	mm	70	152	90	107	3.8 kg
	in.	2.76	5.98	3.54	4.21	8.4 lbs

Table 17: Straightway

Strainer size		A	C	C _{min.}	H	E	F _{min.}	Weight
FIA 15-20 (½" - ¾")	mm	120	99	133	60	20	68	1.4 kg
	in.	4.72	3.90	5.24	2.36	0.79	2.68	3.1 lbs
FIA 25-40 (1" - 1½")	mm	155	129	177	70	26	95	2.4 kg
	in.	6.10	5.08	6.97	2.76	1.02	3.74	5.3 lbs
FIA 50 (2")	mm	148	138	184	77	32	92	3.5 kg
	in.	5.83	5.43	7.24	3.03	1.26	3.62	7.7 lbs
FIA 65 (2½")	mm	176	165	219	90	40	107	5.3 kg
	in.	6.93	6.50	8.62	3.54	1.57	4.21	11.7 lbs

NOTE:

Specified weights are approximate values only.

Strainer housing, type FIA

Figure 9: FIA 80 - 200 Angleway/Straightway

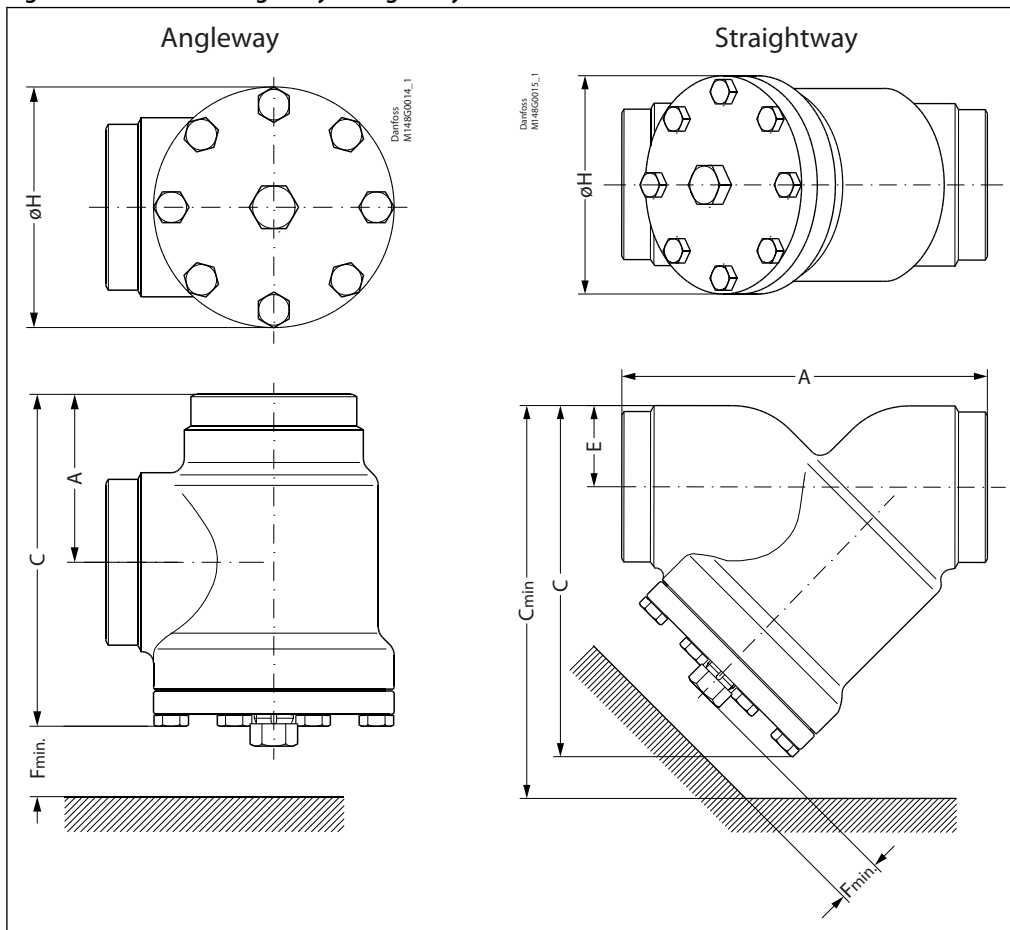

Table 18: Angleway

Strainer size		A	C	øH	F _{min.}	Weight
FIA 80 (3")	mm	90	189	129	133	7.3 kg
	in.	3.54	7.44	5.08	5.24	16.1 lbs
FIA 100 (4")	mm	106	223	156	163	11.9 kg
	in.	4.17	8.78	6.14	6.42	26.2 lbs
FIA 125 (5")	mm	128	268	192	190	21.2 kg
	in.	5.04	10.6	7.56	7.48	46.7 lbs
FIA 150 (6")	mm	145	303	219	223	30.5 kg
	in.	5.71	11.93	8.62	8.78	67.2 lbs
FIA 200 (8")	mm	180	372	276	280	68 kg
	in.	7.09	14.65	10.87	11.02	150 lbs

Table 19: Straightway

Strainer size		A	C	C _{min.}	øH	E	F _{min.}	Weight
FIA 80 (3")	mm	216	204	271	129	48	133	8.6 kg
	in.	8.50	8.03	10.67	5.08	1.89	5.24	19 lbs
FIA 100 (4")	mm	264	256	337	156	60	163	14.9 kg
	in.	10.39	10.08	13.27	6.14	2.36	6.42	32.8 lbs
FIA 125 (5")	mm	322	313	408	192	74	190	26.9 kg
	in.	12.68	12.32	16.06	7.56	2.91	7.48	59.3 lbs
FIA 150 (6")	mm	370	370	482	219	91	223	51 kg
	in.	14.57	14.57	18.98	8.62	3.58	8.78	112 lbs
FIA 200 (8")	mm	464	465	605	276	117	280	95 kg
	in.	18.27	18.31	23.82	10.87	4.61	11.02	209 lbs

NOTE:

Specified weights are approximate values only.

Ordering

Strainer element

Please note that you have to order **FIA strainer without element, a strainer element and accessories.**

Table 20: Strainer elements

FIA size		Strainer insert 100µ 150 mesh	Strainer insert 150µ 100 mesh	Strainer insert 250µ 72 mesh	Strainer insert 500µ 38 mesh	Pleated Strainer insert 150µ 100 mesh	Pleated Strainer insert 250µ 72 mesh	Pleated Strainer insert 500µ 38 mesh
mm	in.							
15	½	148H3122	148H3124	148H3126	148H3128	148H3303	148H3363	-
20	¾							
25	1	148H3123	148H3125	148H3127	148H3129	148H3304	148H3269	-
32	1¼							
40	1½							
50	2	148H3157	148H3130	148H3138	148H3144	148H3179	148H3184	148H3189
65	2½	-	148H3131	148H3139	148H3145	148H3180	148H3185	148H3190
80	3	-	148H3119	148H3120	148H3121	148H3181	148H3186	148H3191
100	4	-	148H3132	148H3140	148H3146	148H3182	148H3187	148H3192
125	5	-	148H3133	148H3141	148H3147	148H3183	148H3188	148H3193
150	6	-	148H3134	148H3142	148H3148	148H3226	148H3293 ⁽¹⁾	-
200	8	-	148H3135	148H3143	148H3149	148H3297	148H3294 ⁽¹⁾	-

⁽¹⁾ 60 mesh

Accessories

Table 21: Accessories

Part	Accessory for	Code number
Magnet insert	FIA 65-100	148H3447
	FIA 125-200	148H3448
Strainer element µ150 with removable element µ50 for the first start up	FIA 15-20	148H3301
	FIA 25-40	148H3302
Filter bag	FIA 50	148H3150
	FIA 65	148H3151
	FIA 80	148H3152
	FIA 100	148H3153
	FIA 125	148H3154
	FIA 150	148H3155
	FIA 200	148H3156
Purge valve complete	FIA 50 - 300	148B3745
Blind nut with gasket		148H3450

Certificates, declarations, and approvals

The list contains all certificates, declarations, and approvals for this product type. Individual code number may have some or all of these approvals, and certain local approvals may not appear on the list.

Some approvals may change over time. You can check the most current status at danfoss.com or contact your local Danfoss representative if you have any questions.

Table 22: Certificates and declarations

File name	Document type	Approval authority
RU Д-DK.БЛ08.В.00828_19	EAC Declaration	EAC
0045 202 1204 Z 00354 19 D 001(00)	Pressure - Safety Certificate	TÜV
03709-F0 BV	Marine - Safety Certificate	BV
RU Д-DK.РА01.В.32851_20	EAC Declaration	EAC
RU C-DK.БЛ08.В.01095_20	Pressure - Safety Certificate	EAC
TAP0000005 Rev. 1	Marine - Safety Certificate	DNV GL
EU 033F0685.AK	EU Declaration	Danfoss
MD 033F0691.AE	Manufacturers Declaration	Danfoss
MD 033F0686.AH	Manufacturers Declaration	Danfoss
0045 202 1204 Z 00355 19 D 001(00)	Pressure - Safety Certificate	TÜV
033F0453.AD	Manufacturers Declaration	Danfoss
19.10048.266	Marine - Safety Certificate	RMRS
CRN.0C16578.523467890YTN	Pressure - Safety Certificate	TSSA
07 202 STK1 Z 0540-2-D-01	Pressure - Safety Certificate	TUV
0045 202 1201 Z 00424 19 D 001(00)	Pressure - Safety Certificate	TÜV

Online support

Danfoss offers a wide range of support along with our products, including digital product information, software, mobile apps, and expert guidance. See the possibilities below.

The Danfoss Product Store



The Danfoss Product Store is your one-stop shop for everything product related—no matter where you are in the world or what area of the cooling industry you work in. Get quick access to essential information like product specs, code numbers, technical documentation, certifications, accessories, and more.

Start browsing at store.danfoss.com.

Find technical documentation



Find the technical documentation you need to get your project up and running. Get direct access to our official collection of data sheets, certificates and declarations, manuals and guides, 3D models and drawings, case stories, brochures, and much more.

Start searching now at www.danfoss.com/en/service-and-support/documentation.

Danfoss Learning



Danfoss Learning is a free online learning platform. It features courses and materials specifically designed to help engineers, installers, service technicians, and wholesalers better understand the products, applications, industry topics, and trends that will help you do your job better.

Create your Danfoss Learning account for free at www.danfoss.com/en/service-and-support/learning.

Get local information and support



Local Danfoss websites are the main sources for help and information about our company and products. Find product availability, get the latest regional news, or connect with a nearby expert—all in your own language.

Find your local Danfoss website here: www.danfoss.com/en/choose-region.

Spare Parts



Get access to the Danfoss spare parts and service kit catalog right from your smartphone. The app contains a wide range of components for air conditioning and refrigeration applications, such as valves, strainers, pressure switches, and sensors.

Download the Spare Parts app for free at www.danfoss.com/en/service-and-support/downloads.

Coolselector®2 - find the best components for you HVAC/R system



Coolselector®2 makes it easy for engineers, consultants, and designers to find and order the best components for refrigeration and air conditioning systems. Run calculations based on your operating conditions and then choose the best setup for your system design.

Download Coolselector®2 for free at coolselector.danfoss.com.

Danfoss A/S

Climate Solutions • danfoss.com • +45 7488 2222

Any information, including, but not limited to information on selection of product, its application or use, product design, weight, dimensions, capacity or any other technical data in product manuals, catalogues descriptions, advertisements, etc. and whether made available in writing, orally, electronically, online or via download, shall be considered informative, and is only binding if and to the extent, explicit reference is made in a quotation or order confirmation. Danfoss cannot accept any responsibility for possible errors in catalogues, brochures, videos and other material. Danfoss reserves the right to alter its products without notice. This also applies to products ordered but not delivered provided that such alterations can be made without changes to form, fit or function of the product.

All trademarks in this material are property of Danfoss A/S or Danfoss group companies. Danfoss and the Danfoss logo are trademarks of Danfoss A/S. All rights reserved.