

**ebm-papst Mulfingen GmbH & Co. KG**

Bachmühle 2 · D-74673 Mulfingen

Phone +49 7938 81-0

Fax +49 7938 81-110

info1@de.ebmpapst.com

www.ebmpapst.com

Limited partnership · Headquarters Mulfingen  
County court Stuttgart · HRA 590344General partner Elektrobau Mulfingen GmbH · Headquarters Mulfingen  
County court Stuttgart · HRB 590142**Nominal data**

<b>Type</b>	<b>A4E350-AN02-32</b>	
<b>Motor</b>	<b>M4E074-DF</b>	
Phase		1~
Nominal voltage	VAC	230
Frequency	Hz	50
Type of data definition		ml
Valid for approval / standard		CE
Speed	min <sup>-1</sup>	1340
Power input	W	165
Current draw	A	0.73
Motor capacitor	µF	4
Capacitor voltage	VDB	400
Capacitor standard		P0 (CE)
Max. back pressure	Pa	90
Min. ambient temperature	°C	-40
Max. ambient temperature	°C	40
Starting current	A	1.4

ml = max. load · me = max. efficiency · fa = running at free air · cs = customer specs · cu = customer unit  
Subject to alterations

**Data according to ErP directive**

		Actual	Request 2013	Request 2015
Installation category	A			
Efficiency category	Static			
Variable speed drive	No			
Specific ratio*	1.00			
Overall efficiency $\eta_{es}$		29	24.7	28.7
Efficiency grade N		40.4	36	40
Power input $P_e$	kW	0.16		
Air flow $q_v$	m <sup>3</sup> /h	2160		
Pressure increase $p_{fs}$	Pa	75		
Speed n	min <sup>-1</sup>	1355		

Data established at point of optimum efficiency

\* Specific ratio =  $1 + p_b / 100\,000\text{ Pa}$ 

## Technical features

<b>Mass</b>	3.4 kg
<b>Size</b>	350 mm
<b>Surface of rotor</b>	Coated in black
<b>Material of blades</b>	PP plastic
<b>Number of blades</b>	5
<b>Direction of air flow</b>	"V"
<b>Direction of rotation</b>	Counter-clockwise, seen on rotor
<b>Type of protection</b>	IP 44; Depending on installation and position as per EN 60034-5 The IP protection is guaranteed only if the provided cable guard and terminal box are installed.
<b>Insulation class</b>	"F"
<b>Humidity class</b>	F2-2
<b>Max. permissible ambient motor temp. (transp./ storage)</b>	+ 80 °C
<b>Min. permissible ambient motor temp. (transp./storage)</b>	- 40 °C
<b>Mounting position</b>	Shaft horizontal or rotor on bottom; rotor on top on request
<b>Condensate discharge holes</b>	Rotor-side
<b>Operation mode</b>	S1
<b>Motor bearing</b>	Ball bearing with anti-freezing grease
<b>Touch current acc. IEC 60990 (measuring network Fig. 4, TN system)</b>	< 0.75 mA
<b>Electrical leads</b>	Prepared for terminal box installation/assembly
<b>Motor protection</b>	Thermal overload protector (TOP) wired internally
<b>Cable exit</b>	Variable
<b>Protection class</b>	I (if protective earth is connected by customer)
<b>Product conforming to standard</b>	EN 60335-1; CE

## Product drawing

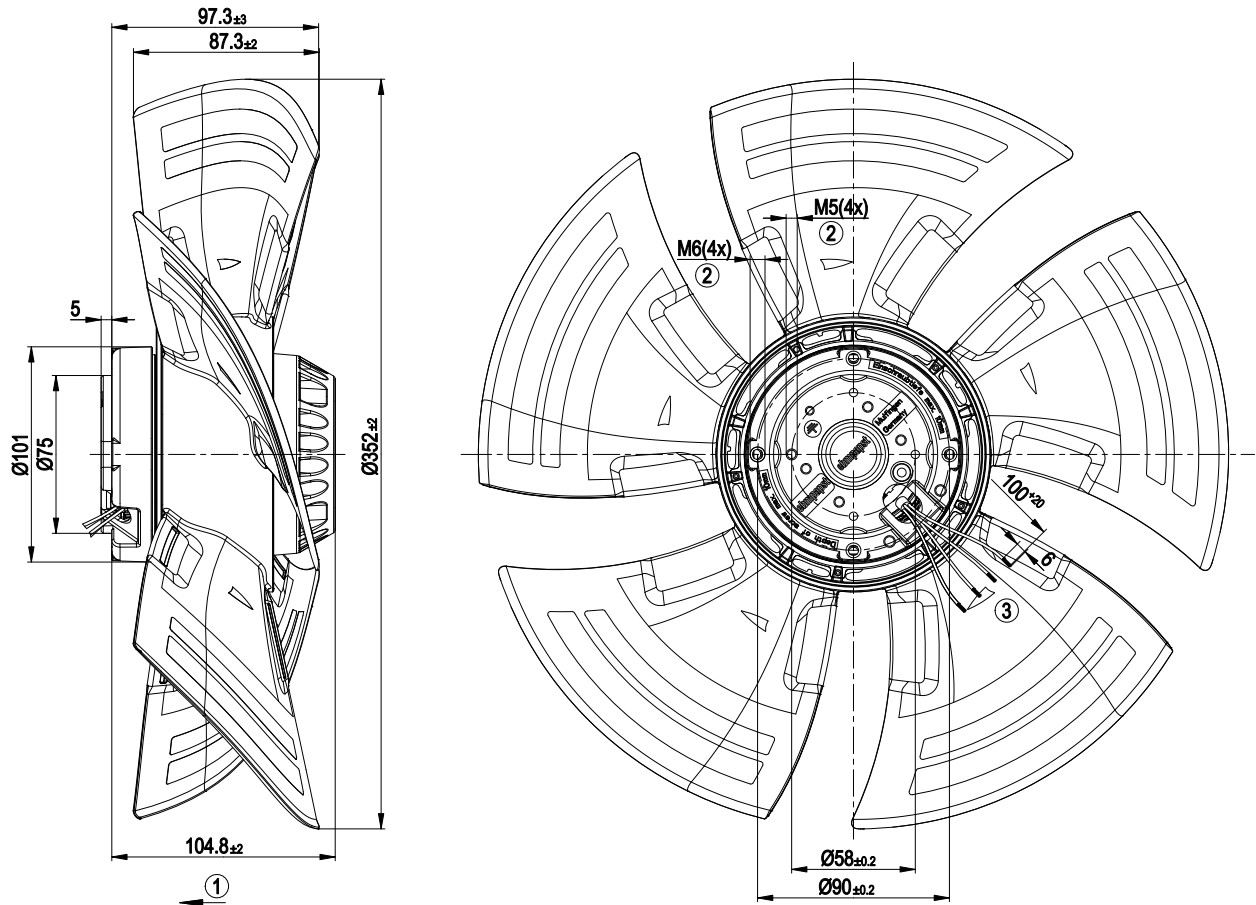

1	Direction of air flow "V"
2	Depth of screw max. 10 mm
3	Connection line Dipotherm 4G 0.5 mm <sup>2</sup> , 4x brass lead tips crimped

## Connection screen



U1	blue	Z	brown	U2	black
PE	green/yellow				

## Charts: Air flow 50 Hz

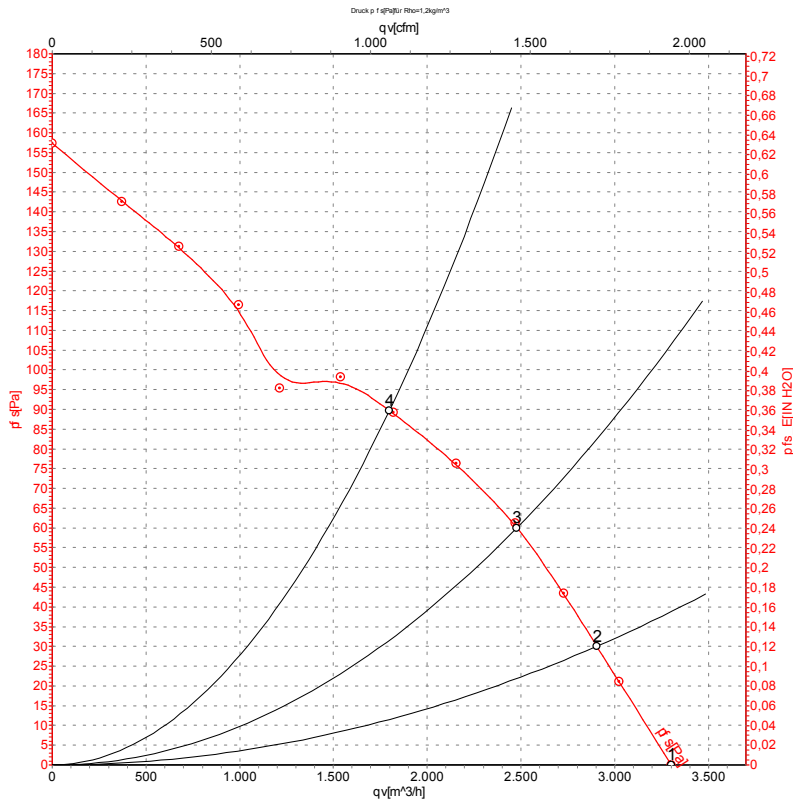

Measurement: LU-131320

Air performance measured as per ISO 5801 Installation category A. For detailed information on the measuring set-up, please contact ebm-papst. Suction-side noise levels: LwA measured as per ISO 13347 / LpA measured with 1m distance to fan axis. The values given are valid under the measuring conditions mentioned above and may vary according to the actual installation situation. With any deviation from the standard set-up, the specific values have to be checked and reviewed with the unit installed.

## Measured values

	U	f	n	P <sub>e</sub>	I	LpA <sub>in</sub>	LwA <sub>in</sub>	qv	p <sub>fs</sub>
	V	Hz	min <sup>-1</sup>	W	A	dB(A)	dB(A)	m <sup>3</sup> /h	Pa
1	230	50	1400	135	0.60	62	69	3305	0
2	230	50	1380	145	0.64	59	66	2905	30
3	230	50	1365	155	0.68	56	64	2480	60
4	230	50	1340	165	0.73	56	64	1800	90

U = Supply voltage · f = Frequency · n = Speed · P<sub>e</sub> = Power input · I = Current draw · LpA<sub>in</sub> = Sound pressure level inlet side · LwA<sub>in</sub> = Sound power level inlet side · qv = Air flow  
 p<sub>fs</sub> = Pressure increase

