

Fans and motors for refrigerated display cases

Product Catalogue 2019-07

ebmpapst

the engineer's choice



Fans and motors for refrigerated display cases

Refrigeration applications in supermarkets make very exacting demands on the technologies used. Alongside great energy efficiency, the most important properties include high reliability and a long service life. Hygiene and product protection are however also absolutely essential. And in certain cases, there is a need to find an appropriate solution for extreme temperatures and particularly confined spaces.

Our fans excel in all these respects. They also offer extremely good performance and smooth operation. Which makes them ideal for use specifically in the refrigeration and freezer sector. ebm-papst can supply a broad product portfolio of energy-saving fans for all areas of application.



Fans and motors for refrigerated display cases

ebmpapst

the engineer's choice



	Page		Page
Information	4	About ebm-papst	4
		The ideal solution for all refrigerated display cases	6
		Quick, simple, retrofit: 1:1 replacement with NiQ	8
		F-gas regulation and natural refrigerants	10
Products	12	Compact fans	12
		Axial fans	24
		Diagonal fans	60
		Tangential fans	68
		NiQ motors	78
Accessories	90	Cables	92
		Hand-held programmer	94
		Plug-in module	95
		Air-inlet grille	96
		Guard grilles	98
		Axial impellers	102
		Mounting brackets	103
Fan housings	104		
Technology	106	Connection diagrams	108
		Technical parameters and scope	120
ebm-papst agents	126		126

Information

Products

Accessories

Technology

Agents

About ebm-papst.

ebm-papst is a leader in ventilation and drive engineering technology and a much sought-after engineering partner in many industries. With around 20,000 different products, we have the perfect solution for practically every requirement. We have placed the highest emphasis on economy and ecology for many years.

We believe the consistent further development of our highly-efficient GreenTech EC technology provides our customers with the best opportunities for the future in industrial digitization. With GreenIntelligence, ebm-papst already offers intelligent networked complete solutions that are unique anywhere in the world today and that secure our customers a decisive advantage.

Six reasons that make us the ideal partner:

Our systems expertise.

You want the best solution for every project. The entire ventilation system must thus be considered as a whole. And that's what we do – with **motor technology** that sets standards, sophisticated **electronics** and **aerodynamic** designs – all from a single source and perfectly matched.

Our spirit of invention.

We are also always able to develop customized solutions for you with our versatile team of over 600 engineers and technicians.

Our lead in technology.

We are not only pioneers and trailblazers in the development of highly efficient EC technology, we also recognized the opportunities of digitization at an early stage. Therefore, we can offer solutions today that combine the highest energy efficiency with the advantages of IoT and digital networking.

Closeness to our customers.

ebm-papst has 25 production locations worldwide (including facilities in Germany, China and the USA), together with 49 sales offices, each of which has a dense network of sales representatives. You will always have a local contact, someone who speaks your language and knows your market.

Our standard of quality.

Our quality management is uncompromising, at every step in every process. This is underscored by our certification according to international standards including DIN EN ISO 9001, TS declaration of conformity and DIN EN ISO 14001.

Our sustainable approach.

Assuming responsibility for the environment, for our employees and for society is an integral part of our corporate philosophy. We develop products with an eye to maximum environmental compatibility, in particular resource-preserving production methods. We promote environmental awareness among our young staff and are actively involved in sports, culture and education. That's what makes us a leading company – and an ideal partner for you.

The story of our success to market and technology pioneer.

- 1963** Founding of **Elektrobau Mulfingen GmbH & Co. KG** by Gerhard Sturm and Heinz Ziehl.
- 1965** First tubeaxial fan developed in EC/DC technology.
- 1966** ebm-papst's success takes off with the new 68 motor.
- 1972** The first ebm foreign subsidiary is established in Sweden.
- 1988** Gerhard Sturm is awarded the Federal Cross of Merit.
- 1990** The sixty-millionth external-rotor fan is produced.
- 1992** Acquisition of **PAPST Motoren GmbH** in St. Georgen.
- 1997** Buyout of the **Landshut** (mvl) plant.
- 1998** Development of first fans with integrated electronics.
- 2003** Change of name to **ebm-papst**.
- 2008** The **HyBlade®** range of fans sets new efficiency standards.
- 2010** **GreenTech** – our sign for energy efficiency and resource preservation.
- 2011** **RadiCal** defines a new standard for EC centrifugal fans.
- 2013** ebm-papst takes over the gearbox specialist Zeitlauf and wins the **German Sustainability Award**.
- 2014** Team partnership with Mercedes-AMG Petronas Formula 1 team.
- 2015** **RadiPac** pushes the limits of efficiency.
- 2016** **AxiBlade** sets new standards in ventilation, refrigeration and air-conditioning.
- 2017** Factory expansions Germany: logistics center in Hollenbach and production unit in Hagenmoos.
- 2018** **GreenIntelligence** becomes the new byword for smart complete solutions.

The ideal solution *for* *all refrigerated display cases.*

Keep cool – even when the requirements are very special.

Refrigeration applications in supermarkets pose special challenges on the technology used. Apart from high energy efficiency, high reliability and long service life are the most important properties. But hygiene and goods protection are also absolutely necessary. In some cases, a suitable solution must also be found for extreme temperatures or particularly tight spaces.

Compact energy-saving fans for refrigerated display cases and freezer cabinets.

Our fans with GreenTech EC technology score excellently in all these points. And they deliver impressively high performance at low noise levels. This makes them ideally suited for normal refrigeration or freezer applications.

No matter the application, ebm-papst provides a broad and consistent product portfolio of energy-saving EC fans. Axial fans are designed for installation beneath the shelves in refrigerated display cases and freezer cabinets, for example. On the other hand, we designed our diagonal fans especially for the back walls of refrigerated display cases and the tight installation situation they often present. Thanks to their extremely flat design, they fit into even the smallest gaps to enable optimum operation.



ebm-papst motors and fans prove their excellence in a wide range of refrigerated display cases and freezer cabinets in supermarkets. What all our solutions have in common: They continuously set new standards, whether it's lowering energy consumption, extending service life, reducing noise or when it comes to speed control and monitoring. Our motors and fans for refrigeration and air-conditioning are able to look back at a long history of success. Write the next chapter in the story and discover the highly innovative, reliable solutions available at ebm-papst.

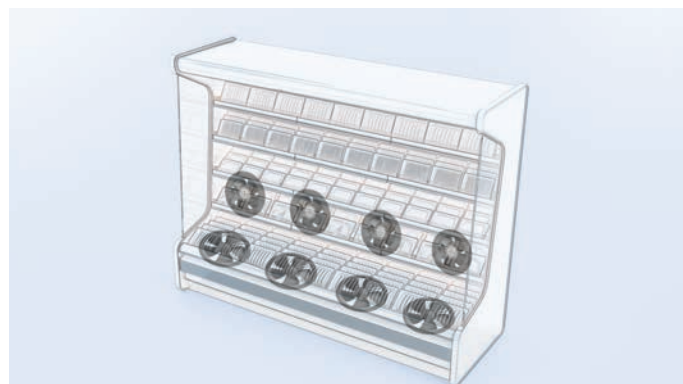

Saving energy *has* no closing time.



An investment that quickly pays off.

Refrigeration systems such as the refrigerated display cases in supermarkets are typically in operation 24/7. Obviously, the energy they consume is a major cost factor. Nowadays, it is more important than ever to save energy. The fans in these systems have long operating times, making them prime candidates for major energy savings. ebm-papst fans are highly efficient, which not only translates into environmental benefits. Ultimately, efficiency has a positive impact on end users' budgets as well. After all, one of the fans' most outstanding properties is their tremendous energy efficiency. And the more fans in use, the greater the potential for savings. Refrigerated display cases are the perfect example.

Small calculation example.

Per running meter, two fans typically operate in a refrigerated display case. If 200 GreenTech EC fans in size 200 are used in a typical supermarket with a total of 100 meters of refrigerated display cases, the energy savings compared to conventional shaded-pole motors would be 70%. Their higher efficiency results in lower intrinsic heat of the energy-saving motor, thus a reduction in operating costs. Every year, this results in a savings potential of 38 MWh and 22 t CO₂. For the environment, this means more than 22 t less carbon emissions (with today's typical energy mix).

At the same time, at an electricity price of 0.1169 €/kWh, users have annual savings of over €4,400. This makes converting existing systems highly profitable, since the investment pays for itself in less than 12 months.

Even small supermarkets benefit from this investment: 40 GreenTech EC fans would save over 9.4 MWh per year. That equals 5.6 t CO₂ and at the electricity price mentioned above, a €1,080 saving on costs. Energy-saving potential in all areas.

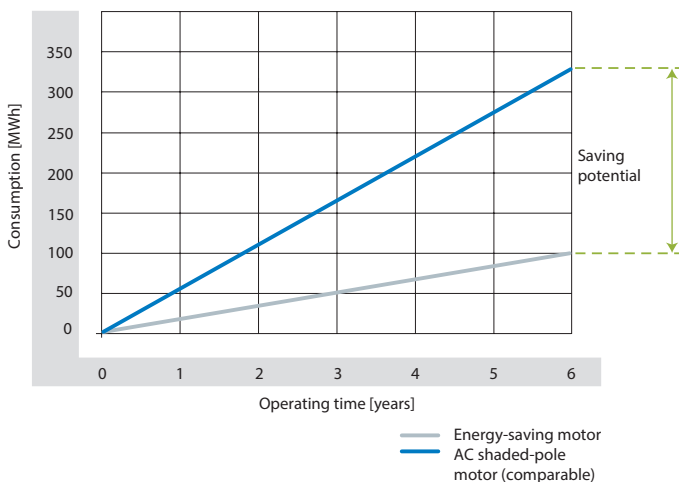

Quick, simple, retrofit: *1:1 replacement with NiQ.*

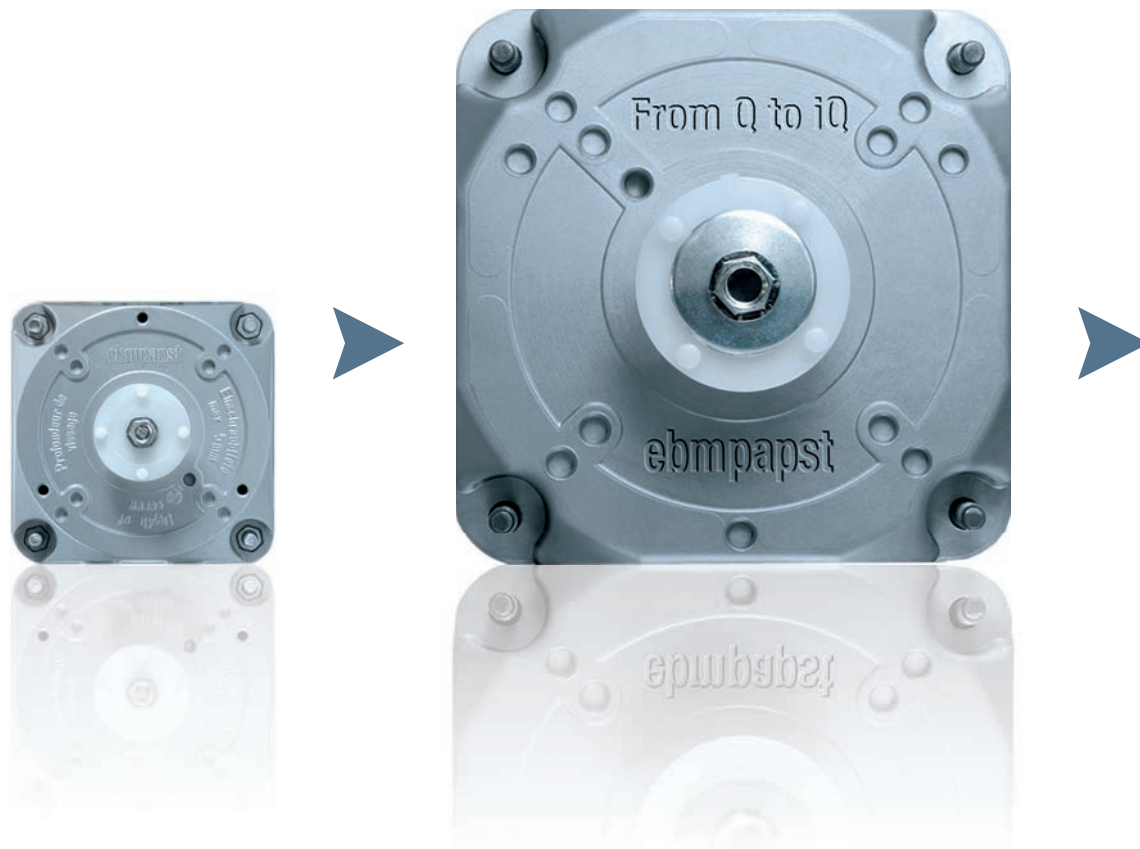

Even today, many fans are still driven by uncontrolled asynchronous motors. Their comparatively low efficiency has an effect on energy consumption in almost all applications. With ebm-papst, you can replace typically inefficient fans containing AC motors 1:1 with highly efficient EC technology of the same mechanical design.

EC motors are extremely efficient, unbeatably compact and run very smoothly. Switching from AC to EC fans not only pays for the environment and user budgets, it also enhances comfort.

The latest generation of energy-saving motors.

Many renowned supermarket chains already use our proven iQ motors today and successfully save energy. In the latest generation, the NiQ, we have not only enhanced the existing advantages but have also added new ones. A modified winding technique and optimized material selection allowed us to improve the product's properties.



With the plastic used, approval in applications involving indirect contact with food (for example in open vegetable display cases) is possible. And in addition to making operations more economical, the NiQ solution was designed to further increase efficiency. Thanks to GreenTech EC technology, it delivers up to 70% more efficiency compared to our old motor concept. Even compared to the iQ and iQ², we were able to increase efficiency in some areas while extending service life and reducing noise.

Ready to retrofit.

Its many benefits and cost savings compared to older motors make our NiQ the first choice when it comes to new developments. But retrofitting existing applications with them also pays off after just a short time. Since the NiQ is mechanically compatible with both shaded-pole motors and the iQ motor series and has the same installation dimensions, 1:1 replacement is possible. This makes ecological and economical sense.

Clear statement: the EU regulation on fluorinated greenhouse gases.

The use of fluorinated greenhouse gases has been officially regulated since 2006. Regulation (EU) 517/2014, also known as the Fluorinated Gas Regulation, has been in force since 1 January 2015. It specifies a reduction in the emission of fluorinated greenhouse gases by 70 million tons of CO₂-equivalent to 35 million tons of CO₂-equivalent in the EU by 2030. And it is also designed to support the use of alternatives such as natural refrigerants.

HFC phasedown.

Another major issue with regard to refrigerated display cases is the refrigerant they use. Partially fluorinated hydrocarbons (HFC) are often used, but they severely damage the climate and contribute to increasing the greenhouse effect. The relative contribution of a refrigerant to the greenhouse effect is called Global Warming Potential (GWP) and expressed in CO₂ equivalents. In fact, commercial refrigeration plants are the biggest source of HFC emissions in Germany. The industry emitted 3.4 million tons of CO₂-equivalent in 2006,

which is almost 35% of total German HFC emissions. This is why the use and phasedown of HFC are officially regulated.

In effect: EU regulation no. 517/2014.

The figure below shows the steps involved in official regulation and the prohibitions that have gone into effect.

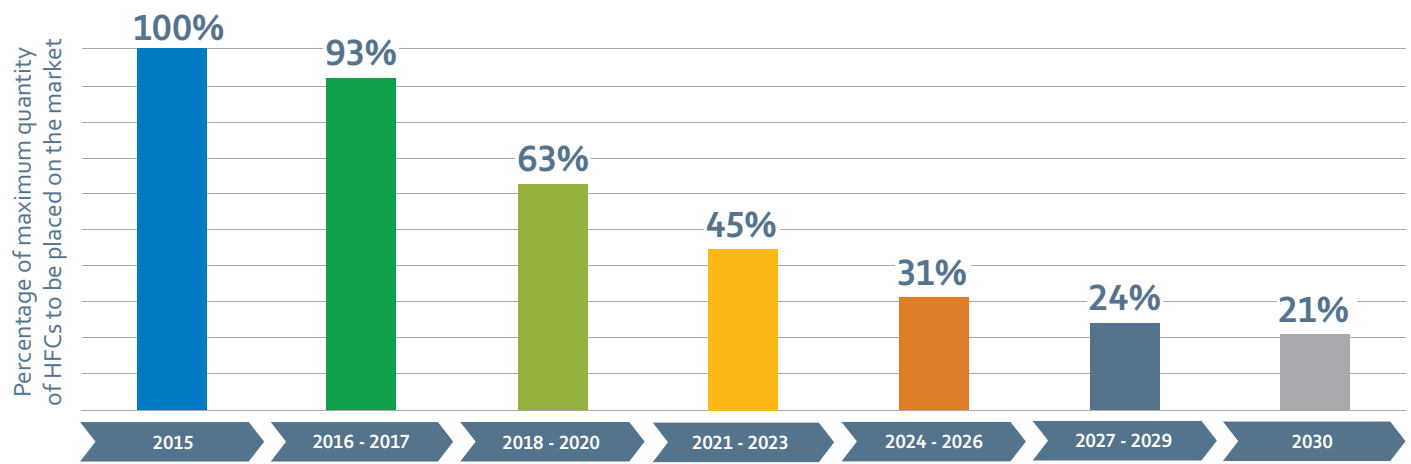

	from 1 January 2015	from 1 January 2020	from 1 January 2022
Placing on the market prohibitions	Domestic refrigerators and freezers that contain HFCs with GWP of 150 or more.	Stationary refrigeration equipment, that contains, or whose functioning relies upon, HFCs with GWP of 2,500 or more except equipment intended for application designed to cool products to temperatures below -50 °C.	Multipack centralised refrigeration systems for commercial use with a rated capacity of 40 kW or more that contain, or whose functioning relies upon, F-gases with GWP of 150 or more, except in the primary refrigerant circuit of cascade systems where F-gases with a GWP of less than 1,500 may be used.
		Refrigerators and freezers for commercial use (hermetically sealed equipment) that contain HFCs with GWP of 2,500 or more.	Refrigerators and freezers for commercial use (hermetically sealed equipment) that contain HFCs with GWP of 150 or more.

The alternative: *natural refrigerant.*



Stop and rethink.

In the wake of the Fluorinated Gas Regulation, the choice of refrigerant has gained in importance. As environmentally friendly alternatives to HFC, natural refrigerants such as propane (P290) and carbon dioxide CO₂ (R744) are increasingly popular. They enjoy virtually unlimited availability, have a minimal global warming potential and ensure a beneficial climate balance in refrigerated display cases. When malfunctions occur, flammable refrigerants such as R290 (refrigerants of safety class A3) can form highly explosive mixtures in combination with air. This is why switching to low-GWP refrigerants means refrigerating plants and integrated components with special construction requirements and variants. They are specified in European standard DIN EN 378.

Play it safe with ebm-papst.

To provide a safe cooling solution, all our motors and complete systems meet the European standard EN 60335-2-24 or -89 (Household appliance standard) as standard. This is fully adequate for most refrigerated display cases, since their cooling circuits work with the 150 or 500 g maximum refrigerant quantity required by the standard. In these cases, ATEX components are usually not necessary.

For refrigerating plants with over 150 or 500 g refrigerant, it may make sense to divide the plants into several circuits. If that is not possible, we also offer a suitable solution: ebm-papst fans with energy-saving motors with ATEX approval II 3G nA IIA T4. They meet ATEX standard EN 60079 and are therefore also approved for use in large refrigerated display cases, composite and cascade systems.



Compact fans

ebmpapst

the engineer's choice

	Page
8300N (□ 80 x 32 mm)	14
3300N (□ 92 x 32 mm)	16
4300N (□ 119 x 32 mm)	18
ACi4400 (□ 119 x 38 mm)	20
ACi4400N (□ 119 x 38 mm)	22

DC compact fans

□ 80 x 32 mm



Material/surface

- Housing: plastic
- Impeller: plastic

Mechanical data

- Number of blades: 5
- Direction of airflow: blowing over struts ("V")
- Direction of rotation: counter-clockwise viewed toward rotor
- Degree of protection: IP 68
- Insulation class: "E"
- Installation position: any
- Mode: continuous operation (S1)
- Mounting: maintenance-free ball bearings

Electrical data

- Motor protection: EP (Electronic Protection)
- Electrical hookup: leads AWG 26 stripped and tin-plated
- Cable exit: lateral
- Protection class: III
- Speed levels: with infinitely variable control (optional)

Standards and approvals

- Conformity with standards: EN 60335-1*; EN 60335-2-24*; EN 60335-2-89*; EN 60335-2-80*
- Approvals:
VDE: EN 60950-1; EN 62368-1
UL: UL 507
CSA: C22.2 No. 113-15
TÜV: EN 60079-07

* Customer back-up fuse necessary to satisfy this standard.
The fuse rating is available on request.

on Page 90	Accessories
on Page 108	Connection diagrams and technical features
on Page 120	Technical parameters and scope
More at	www.ebmpapst.com

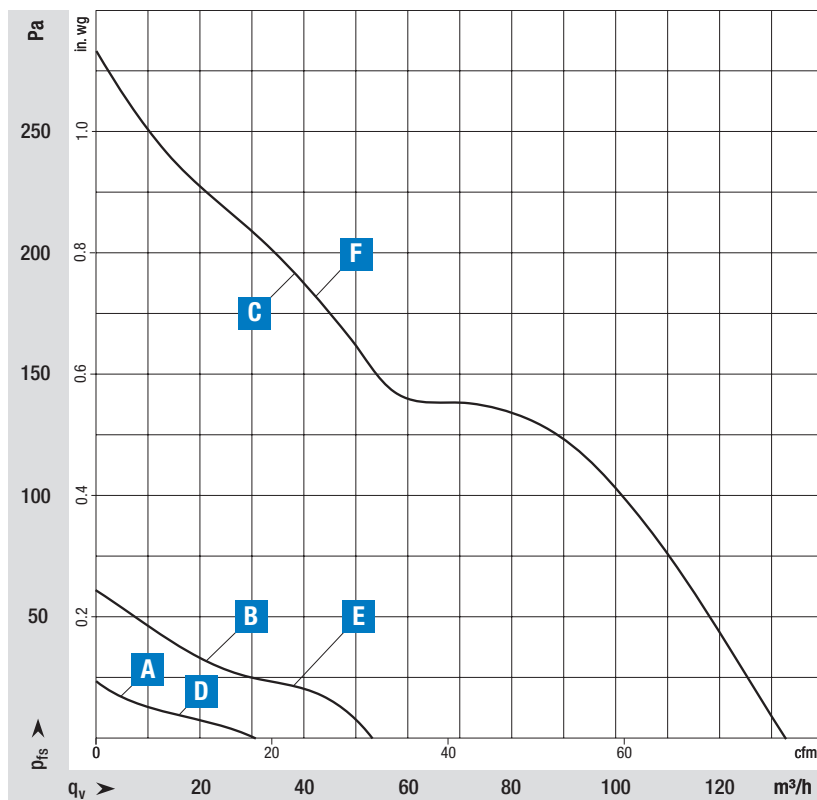

Measuring requirements

Air performance measured according to: ISO 5801, installation category A, in ebm-papst full nozzle without contact protection.
Intake-side sound level: L_{pA} according to ISO 13347, L_{pA} measured at 1 m distance from fan axis. The values given are only applicable under the specified measuring conditions and may differ depending on the installation conditions. In the event of deviation from the standard configuration, the parameters must be checked in installed condition.

Curve	Nominal voltage VDC	Speed n min ⁻¹	Max. input power P _{ed} W	Max. input current I A	Sound power level L _w /A dB(A)	Max. back pressure ⁽¹⁾ Pa	Perm. ambient temp. °C	Conn. diagram
Voltage range 6-15 VDC								
A	12	2300	1.0	0.08	40	5	-20...+75	ESM8)
B	12	3800	1.8	0.15	45	20	-20...+75	
Voltage range 6-12.8 VDC								
C	12	8500	13	1.08	66	125	-20...+70	ESM8)
Voltage range 12-28 VDC								
D	24	2300	1.0	0.04	40	5	-20...+75	ESM8)
E	24	3800	1.8	0.08	45	20	-20...+75	
Voltage range 18-28 VDC								
F	24	8500	12	0.50	66	125	-20...+75	ESM8)

Subject to change. ⁽¹⁾Max. recommended back pressure before saddle area.

Curve	DC compact fans	
	Part number	Weight kg
A	8312 NLU	0.16
B	8312 NNU	0.16
C	8312 NH4U	0.16
D	8314 NLU	0.16
E	8314 NNU	0.16
F	8314 NH4U	0.16

Engineering drawing

Dimensions in mm

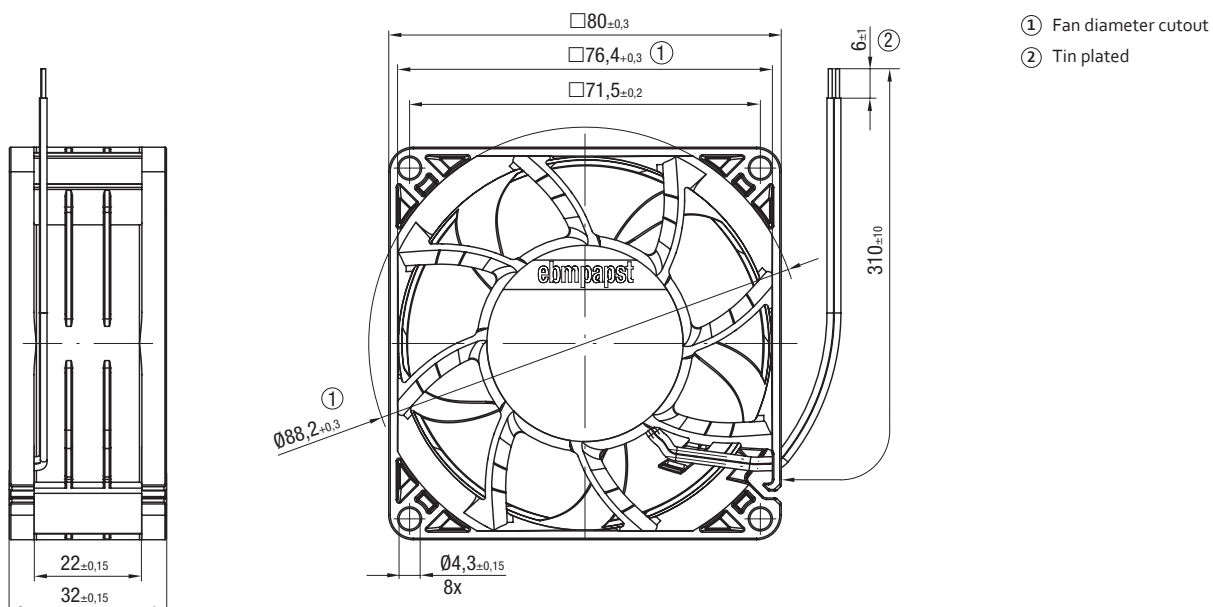

DC compact fans

□ 92 x 32 mm



Material/surface

- Housing: plastic
- Impeller: plastic

Mechanical data

- Number of blades: 5
- Direction of airflow: blowing over struts ("V")
- Direction of rotation: clockwise viewed toward rotor
- Degree of protection: IP 68
- Insulation class: "E"
- Installation position: any
- Mode: continuous operation (S1)
- Mounting: maintenance-free ball bearings

Electrical data

- Motor protection: EP (Electronic Protection)
- Electrical hookup: leads AWG 24 stripped and tin-plated
- Cable exit: lateral
- Protection class: III
- Speed levels: with infinitely variable control (optional)

Standards and approvals

- Conformity with standards: EN 60335-1*; EN 60335-2-24*; EN 60335-2-89*; EN 60335-2-80*
- Approvals:
VDE: EN 60950-1; EN 62368-1
UL: UL 507
CSA: C22.2 No. 113-15
TÜV: EN 60079-07

* Customer back-up fuse necessary to satisfy this standard.
The fuse rating is available on request.

on Page 90	Accessories
on Page 108	Connection diagrams and technical features
on Page 120	Technical parameters and scope
More at	www.ebmpapst.com

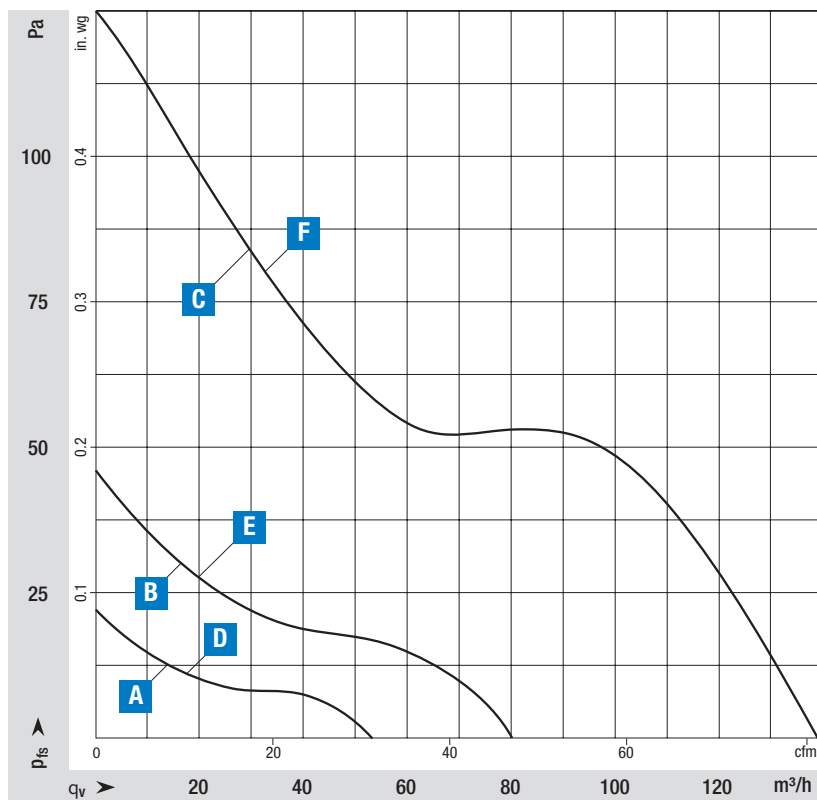

Measuring requirements

Air performance measured according to: ISO 5801, installation category A, in ebm-papst full nozzle without contact protection.
Intake-side sound level: L_{pA} according to ISO 13347, L_{pA} measured at 1 m distance from fan axis. The values given are only applicable under the specified measuring conditions and may differ depending on the installation conditions. In the event of deviation from the standard configuration, the parameters must be checked in installed condition.

Curve	Nominal voltage VDC	Speed n min ⁻¹	Max. input power P _{ed} W	Max. input current I A	Sound power level L _w /A dB(A)	Max. back pressure ⁽¹⁾ Pa	Perm. ambient temp. °C	Conn. diagram
Voltage range 6-15VDC								
A	12	1850	0.8	0.07	41	5	-20...+75	ESM8)
B	12	2650	1.8	0.15	47	15	-20...+75	
Voltage range 6-14 VDC								
C	12	4350	6.7	0.56	60	50	-20...+70	ESM8)
Voltage range 12-28VDC								
D	24	1850	1.0	0.04	41	5	-20...+75	ESM8)
E	24	2650	1.8	0.08	47	15	-20...+75	
F	24	4350	6.0	0.25	60	50	-20...+75	

Subject to change. ⁽¹⁾ Max. recommended back pressure before saddle area.

Curve	DC compact fans	
	Part number	Weight kg
A	3312 NLU	0.19
B	3312 NNU	0.19
C	3312 NH3U	0.19
D	3314 NLU	0.19
E	3314 NNU	0.19
F	3314 NH3U	0.19

Engineering drawing

Dimensions in mm

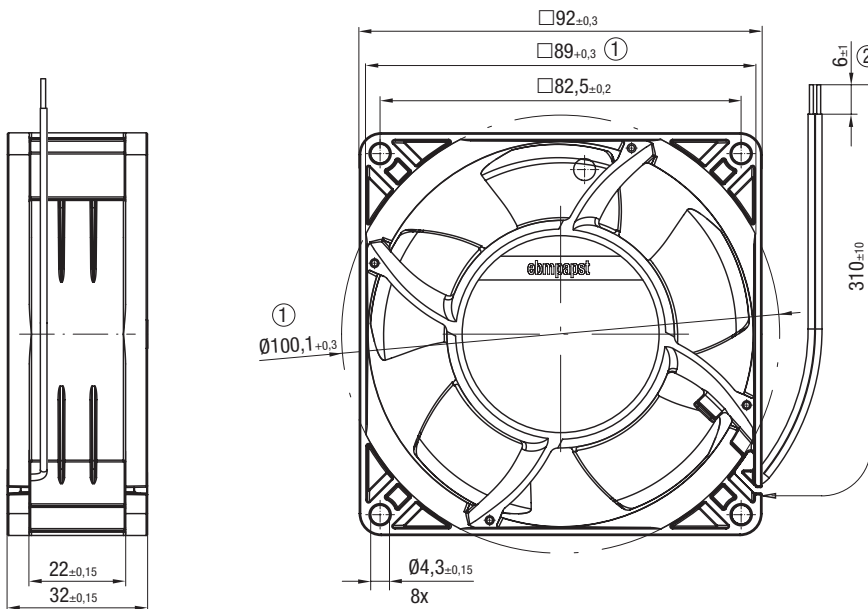

- ① Fan diameter cutout
- ② Tin plated

DC compact fans

□ 119 x 32 mm



on Page 90	Accessories
on Page 108	Connection diagrams and technical features
on Page 120	Technical parameters and scope
More at	www.ebmpapst.com

Material/surface

- Housing: plastic
- Impeller: plastic

Mechanical data

- Number of blades: 5
- Direction of airflow: blowing over struts ("V")
- Direction of rotation: clockwise viewed toward rotor
- Degree of protection: IP 68
- Insulation class: "E"
- Installation position: any
- Mode: continuous operation (S1)
- Mounting: maintenance-free ball bearings

Electrical data

- Motor protection: EP (Electronic Protection)
- Electrical hookup: Leads AWG 24 stripped and tin-plated
- Cable exit: lateral
- Protection class: III
- Speed levels: with infinitely variable control (optional)

Standards and approvals

- Conformity with standards: EN 60335-1*; EN 60335-2-24*; EN 60335-2-89*; EN 60335-2-80*
- Approvals:
VDE: EN 60950-1; EN 62368-1
4300N mit LIN: EN 60335-1
UL: UL 507
CSA: C22.2 No. 113-15
TÜV: EN 60079-07

* Customer back-up fuse necessary to satisfy this standard.
The fuse rating is available on request.

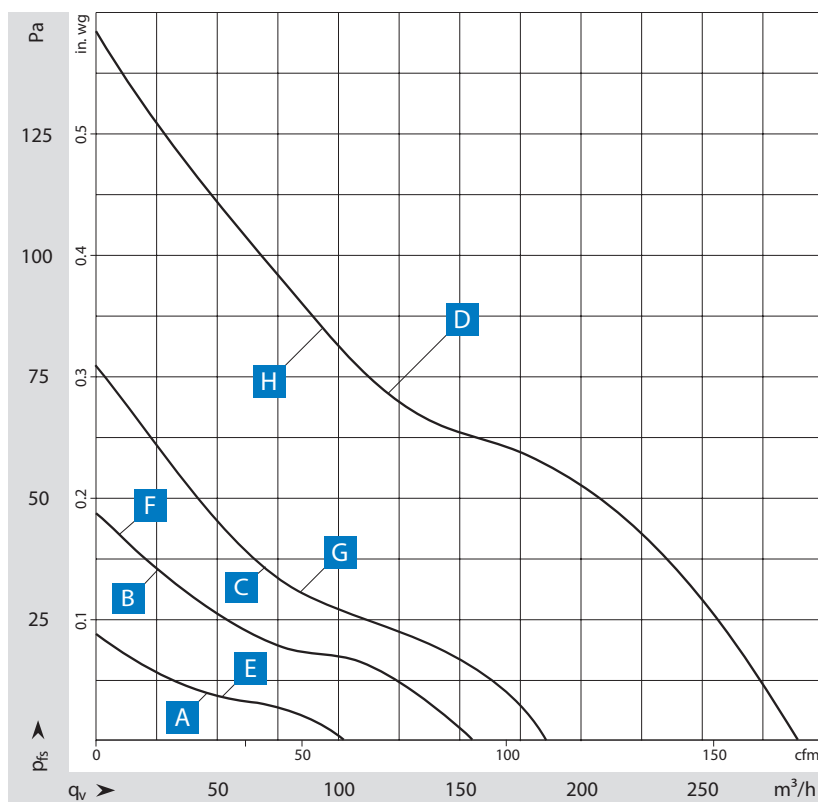

Measuring requirements

Air performance measured according to: ISO 5801, installation category A, in ebm-papst full nozzle without contact protection.
Intake-side sound level: L_{pA} according to ISO 13347, L_{pA} measured at 1 m distance from fan axis. The values given are only applicable under the specified measuring conditions and may differ depending on the installation conditions. In the event of deviation from the standard configuration, the parameters must be checked in installed condition.

Curve	Nominal voltage VDC	Speed n min ⁻¹	Max. input power P _{ed} W	Max. input current I A	Sound power level L _w /A dB(A)	Max. back pressure ⁽¹⁾ Pa	Perm. ambient temp. °C	Conn. diagram
Voltage range 6-15 VDC								
A	12	1450	0.9	0.08	41	5	-20...+75	ESM8)
B	12	2100	2.2	0.18	47	15	-20...+75	
C	12	2700	4.3	0.36	54	25	-20...+75	
Voltage range 7-13.2 VDC								
D	12	4050	12	1.00	66	50	-20...+70	ESM8)
Voltage range 12-28 VDC								
E	24	1450	1.0	0.04	41	5	-20...+75	ESM8)
F	24	2100	2.4	0.10	47	15	-20...+75	
G	24	2700	4.1	0.17	54	25	-20...+75	
Voltage range 14-26.4 VDC								
H	24	4050	11	0.46	66	50	-20...+70	ESM8)

Subject to change. ⁽¹⁾Max. recommended back pressure before saddle area.

Curve	DC compact fans	
	Part number	Weight kg
A	4312 NLU	0.25
B	4312 NMU	0.25
C	4312 NNU	0.25
D	4312 NH3U	0.25
E	4314 NLU	0.25
F	4314 NMU	0.25
G	4314 NNU	0.25
H	4314 NH3U	0.25

Engineering drawing

Dimensions in mm

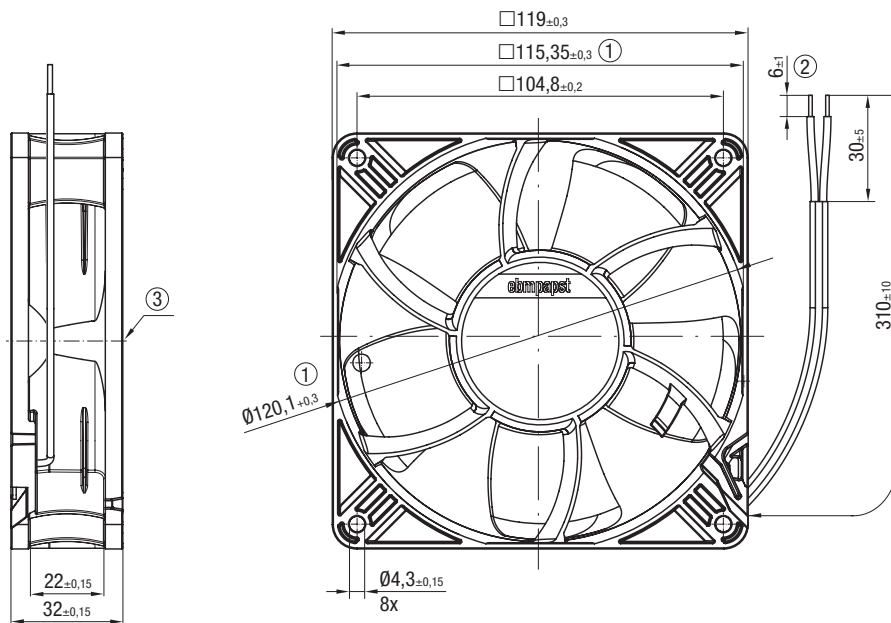

- ① Fan diameter cutout
- ② Tin plated
- ③ Rotor protrusion max. 0.4 mm

EC compact fans

□ 119 x 38 mm



Material/surface

- Housing: plastic
- Impeller: plastic

Mechanical data

- Number of blades: 5
- Direction of airflow: blowing over struts ("V")
- Direction of rotation: clockwise viewed toward rotor
- Degree of protection: IP 65
- Insulation class: "E"
- Installation position: any
- Mode: continuous operation (S1)
- Mounting: maintenance-free ball bearings

Electrical data

- Motor protection: EP (Electronic Protection)
- Electrical hookup: Leads AWG 24 stripped and tin-plated
- Cable exit: lateral
- Protection class: built-in fan
- Speed levels: with infinitely variable control (optional)

Standards and approvals

- Conformity with standards: EN 60335-2-80
- Approvals:
VDE: EN 60950-1; EN 62368-1; EN 60335-1;
EN 60335-2-24; EN 60335-2-89
UL: UL 507; UL 1004-1; UL 1004-7; UL 508C
CSA: C22.2 No. 113-15

on Page 90	Accessories
on Page 108	Connection diagrams and technical features
on Page 120	Technical parameters and scope
More at	www.ebmpapst.com

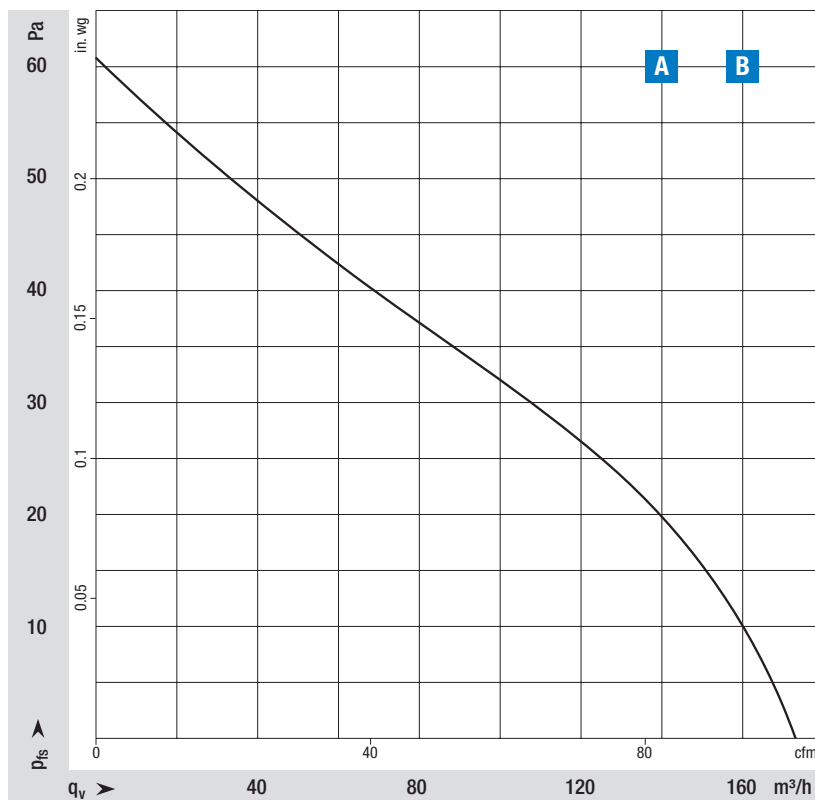

Measuring requirements

Air performance measured according to: ISO 5801, installation category A, in ebm-papst full nozzle without contact protection.
Intake-side sound level: L_{pA} according to ISO 13347, L_{pA} measured at 1 m distance from fan axis. The values given are only applicable under the specified measuring conditions and may differ depending on the installation conditions. In the event of deviation from the standard configuration, the parameters must be checked in installed condition.

Curve	Nominal voltage VAC	Speed n min ⁻¹	Max. input power P _{ed} W	Max. input current I A	Sound power level L _w /A dB(A)	Max. back pressure ⁽¹⁾ Pa	Perm. ambient temp. °C	Conn. diagram
Voltage range 90-264 VAC								
A	100...240	3300	4.6	0.10	55	30	-40...+75	ESM5)
B	100...240	3300	4.6	0.10	55	30	-40...+75	ESM6)

Subject to change. ⁽¹⁾ Max. recommended back pressure before saddle area.

EC compact fans		
Curve	Part number	Weight kg
A	ACi 4400/2 HHAU ⁽²⁾	0.275
B	ACi 4400/2 HHPU ⁽³⁾	0.275

⁽²⁾ With analog input 5-10 V. ⁽³⁾ With PWM interface.

Engineering drawing

Dimensions in mm

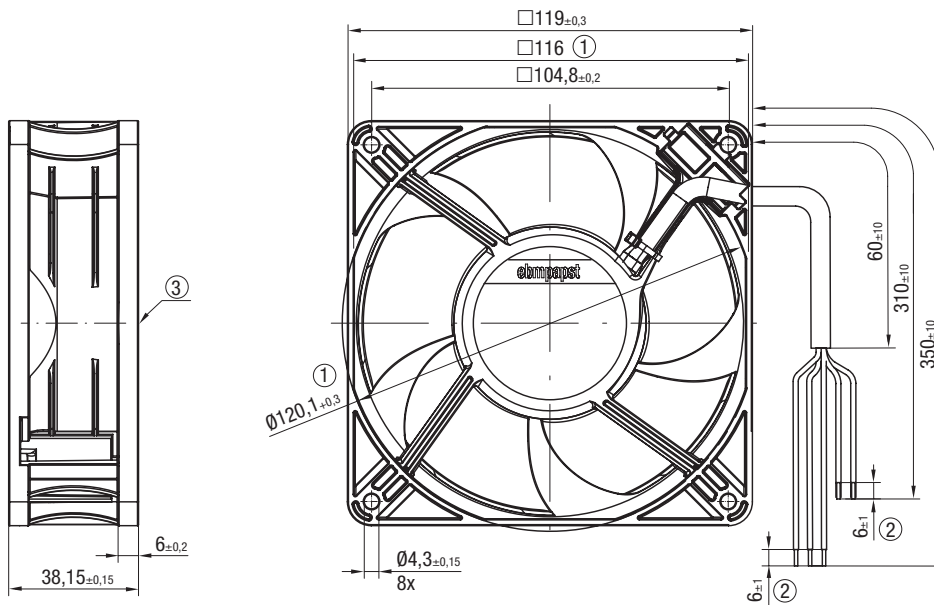

- ① Dimension for worktop mounting
- ② Tin plated
- ③ Rotor protrusion max. 0.6 mm

EC compact fans

□ 119 x 38 mm



Material/surface

- Housing: plastic
- Impeller: plastic

Mechanical data

- Number of blades: 5
- Direction of airflow: blowing over struts ("V")
- Direction of rotation: clockwise viewed toward rotor
- Degree of protection: IP 65
- Insulation class: "E"
- Installation position: any
- Mode: continuous operation (S1)
- Mounting: maintenance-free ball bearings

Electrical data

- Motor protection: EP (Electronic Protection)
- Electrical hookup: Einzellitzen AWG 24 abisoliert und verzinkt
- Cable exit: lateral
- Protection class: built-in fan
- Speed levels: with infinitely variable control (optional)

Standards and approvals

- Conformity with standards: EN 60335-2-80
- Approvals:
VDE: EN 60950-1; EN 62368-1; EN 60335-2-24; EN 60335-2-89
UL: UL 507; UL 60335
CSA: C22.2 No. 113-15

on Page 90	Accessories
on Page 108	Connection diagrams and technical features
on Page 120	Technical parameters and scope
More at	www.ebmpapst.com

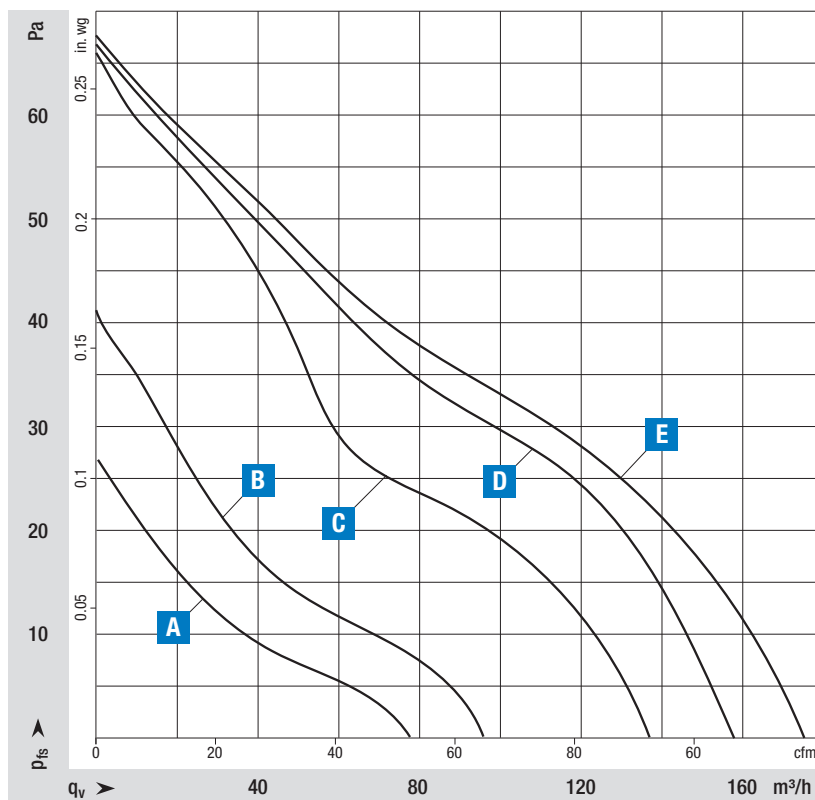

Measuring requirements

Air performance measured according to: ISO 5801, installation category A, in ebm-papst full nozzle without contact protection.
Intake-side sound level: L_{pA} according to ISO 13347, L_{pA} measured at 1 m distance from fan axis. The values given are only applicable under the specified measuring conditions and may differ depending on the installation conditions. In the event of deviation from the standard configuration, the parameters must be checked in installed condition.

Curve	Nominal voltage VAC	Speed n min ⁻¹	Max. input power P _{ed} W	Max. input current I A	Sound power level L _w /A dB(A)	Max. back pressure ⁽¹⁾ Pa	Perm. ambient temp. °C	Conn. diagram
Voltage range 90-264 VAC								
A	100...240	1500	1.1	0.04	37	5	-40...+75	ESM7)
B	100...240	1850	1.7	0.06	41	8	-40...+75	
C	100...240	2700	2.8	0.13	48	25	-40...+75	
D	100...240	3000	3.6	0.15	52	30	-40...+70	
E	100...240	3300	4.4	0.15	55	35	-40...+70	

Subject to change. ⁽¹⁾ Max. recommended back pressure before saddle area.

EC compact fans		
Curve	Part number	Weight kg
A	ACi 4400 NLU	0.275
B	ACi 4400 NMLU	0.275
C	ACi 4400 NNU	0.275
D	ACi 4400 NHU	0.275
E	ACi 4400 NHHU	0.275

Engineering drawing

Dimensions in mm

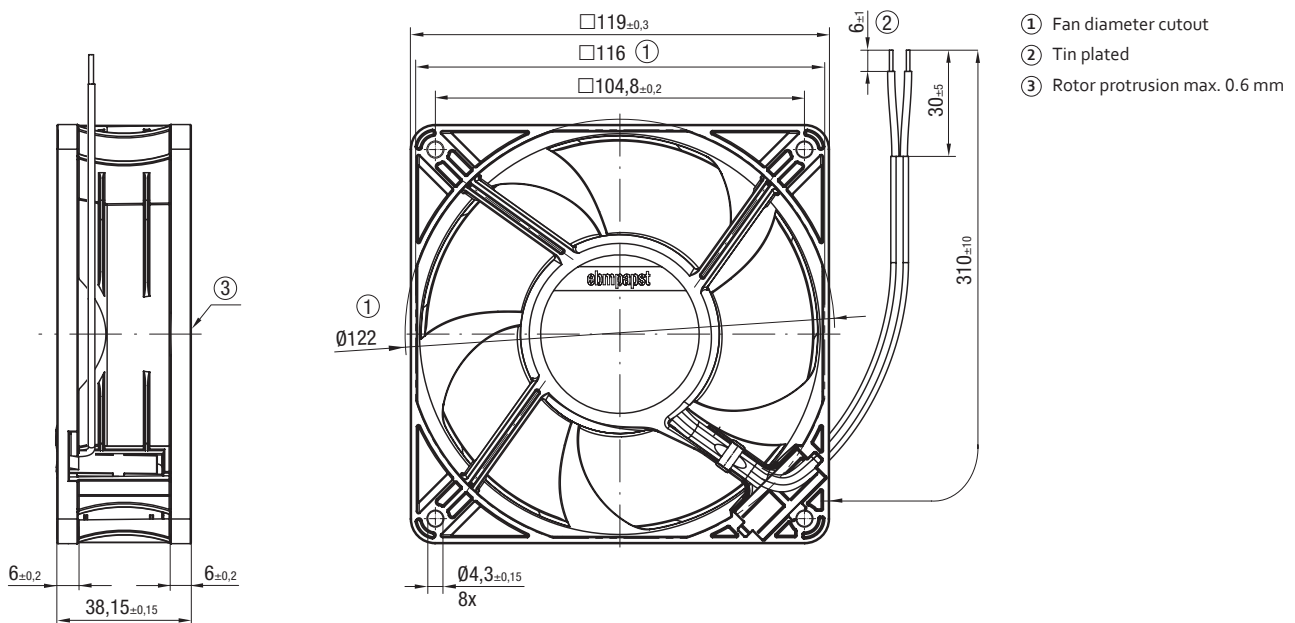



Axial fans

ebmpapst

the engineer's choice

	Page
Ø 130 mm	26
Ø 154 mm	28
Ø 172 mm	32
Ø 200 mm	36
Ø 230 mm	52
Ø 250 mm	54
Ø 300 mm	58

EC axial fans

Ø 130 mm, 2 speed levels (programmable)



on Page 90	Accessories
on Page 108	Connection diagrams and technical features
on Page 120	Technical parameters and scope
More at	www.ebmpapst.com

Material/surface

- Housing: plastic
- Impeller: plastic

Mechanical data

- Number of blades: 7
- Direction of airflow: blowing over struts ("V")
- Direction of rotation: counter-clockwise viewed toward rotor
- Degree of protection: IP 55
- Insulation class: "B"
- Installation position: any
- Mode: continuous operation (S1)
- Mounting: maintenance-free ball bearings

Electrical data

- Motor protection: thermal overload protector (TOP) internally connected
- Electrical hookup: cable for connection on motor side
- Cable exit: lateral
- Protection class: II
- Speed levels: 2 (programmable)

EMC

- Immunity to interference: according to EN 61000-6-2 (industrial environment)
- Interference emission: according to EN 61000-6-3 (household environment)
- System disturbance: according to EN 61000-3-2/3

Standards and approvals

- Conformity with standards: EN 60335-1; EN 60335-2-24; EN 60335-2-80; EN 60335-2-89; CE
- Approvals:
 - A** UL 1004-3 + 60730-1; EAC; VDE; CSA C22.2 No. 77 + CAN/CSA-E60730-1
 - B** UL 1004-3 + 60730-1; EAC; VDE; CCC; CSA C22.2 No. 77 + CAN/CSA-E60730-1

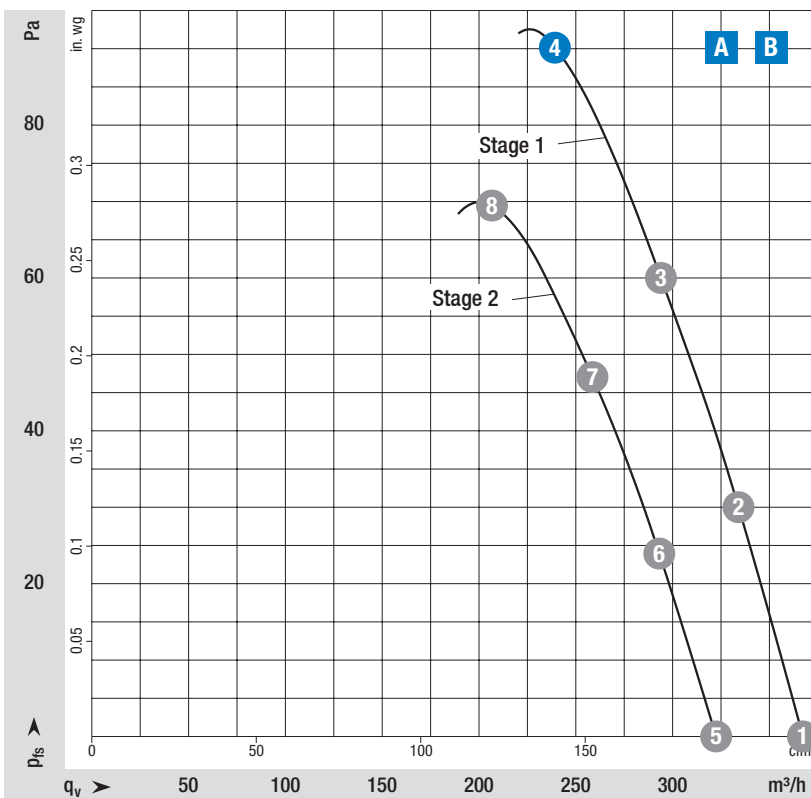

Measuring requirements

Air performance measured according to: ISO 5801, installation category A, in ebm-papst full nozzle without contact protection.
Intake-side sound level: L_{pA} according to ISO 13347, L_{pA} measured at 1 m distance from fan axis. The values given are only applicable under the specified measuring conditions and may differ depending on the installation conditions. In the event of deviation from the standard configuration, the parameters must be checked in installed condition.

Curve	Operating point	Nominal voltage	Frequency	Speed n	Input power P _{ed}	Input current I	Sound power level L _w /A	Back pressure ⁽¹⁾	Ferrn. ambient temp.	Conn. diagram
		VAC	Hz	min ⁻¹	W	A	dB(A)	Pa	°C	
Nominal voltage 115 VAC										
A	1 Stage 1	115	50/60	3200	23	0.35	63	0	-30...+60	ESM1)
	2 Stage 1	115	50/60	3200	23	0.35	63	30		
	3 Stage 1	115	50/60	3200	24	0.37	61	60		
	4 Stage 1	115	50/60	3200	24	0.38	62	90		
	5 Stage 2	115	50/60	2800	15	0.24	61	0		
	6 Stage 2	115	50/60	2800	16	0.24	61	24		
	7 Stage 2	115	50/60	2800	16	0.25	61	46		
	8 Stage 2	115	50/60	2800	16	0.24	61	70		
Nominal voltage 230 VAC										
B	1 Stage 1	230	50/60	3200	23	0.19	63	0	-30...+60	ESM1)
	2 Stage 1	230	50/60	3200	24	0.19	61	30		
	3 Stage 1	230	50/60	3200	24	0.19	60	60		
	4 Stage 1	230	50/60	3200	24	0.19	63	90		
	5 Stage 2	230	50/60	2800	16	0.13	60	0		
	6 Stage 2	230	50/60	2800	16	0.13	58	24		
	7 Stage 2	230	50/60	2800	16	0.13	57	47		
	8 Stage 2	230	50/60	2800	16	0.13	61	70		

Values set in blue are nominal data at operating point with maximum load and 115 or 230 VAC.

Subject to change. ⁽¹⁾ Max. recommended back pressure before saddle area.

Curve	EC axial fans	
	Part number	Weight
A	W1G130AA4901	0.75 kg
B	W1G130AA2501	0.75 kg

Engineering drawing

Dimensions in mm

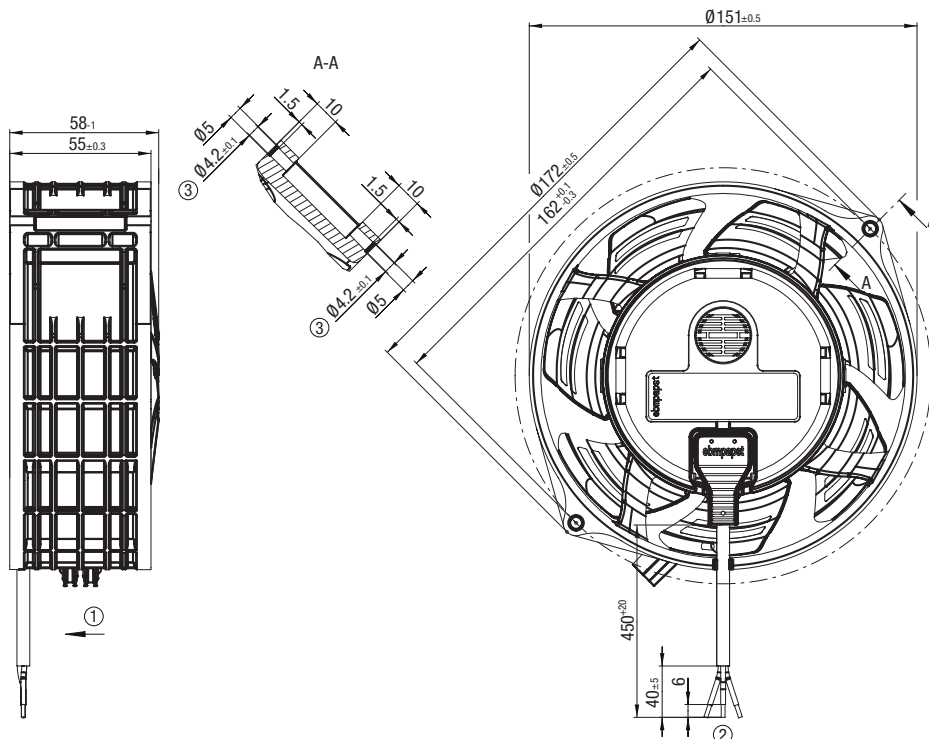

- ① Direction of airflow: "V"
- ② Cable PVC AWG20, 3x crimped splice
- ③ Use should preferably be made of 2x Remform screws WN-156-2 5.0x16 Torx galvanized from Arnold. Alternatively, 2x metric M4 bolts fastened with nuts

EC axial fans

Ø 154 mm, 2 speed levels (not programmable), 100-240 V



Material/surface

- Housing: plastic
- Impeller: plastic

Mechanical data

- Number of blades: 5
- Direction of airflow: blowing over struts ("V")
- Direction of rotation: counter-clockwise viewed toward rotor
- Degree of protection: IP 55
- Insulation class: "B"
- Installation position: any
- Mode: continuous operation (S1)
- Mounting: maintenance-free ball bearings

Electrical data

- Motor protection: electronic
- Electrical hookup: cable for connection on motor side
- Cable exit: lateral
- Protection class: II
- Speed levels: 2 (not programmable)

Standards and approvals

- Conformity with standards: EN 60335-1; EN 60335-2-24; EN 60335-2-80; EN 60335-2-89
- Approvals:
 - A** EAC; VDE
 - B** EAC; VDE; UL 1004-7 + 60730; CSA C22.2 No. 77 + CAN/CSA-E60730-1

on Page 90	Accessories
on Page 108	Connection diagrams and technical features
on Page 120	Technical parameters and scope
More at	www.ebmpapst.com

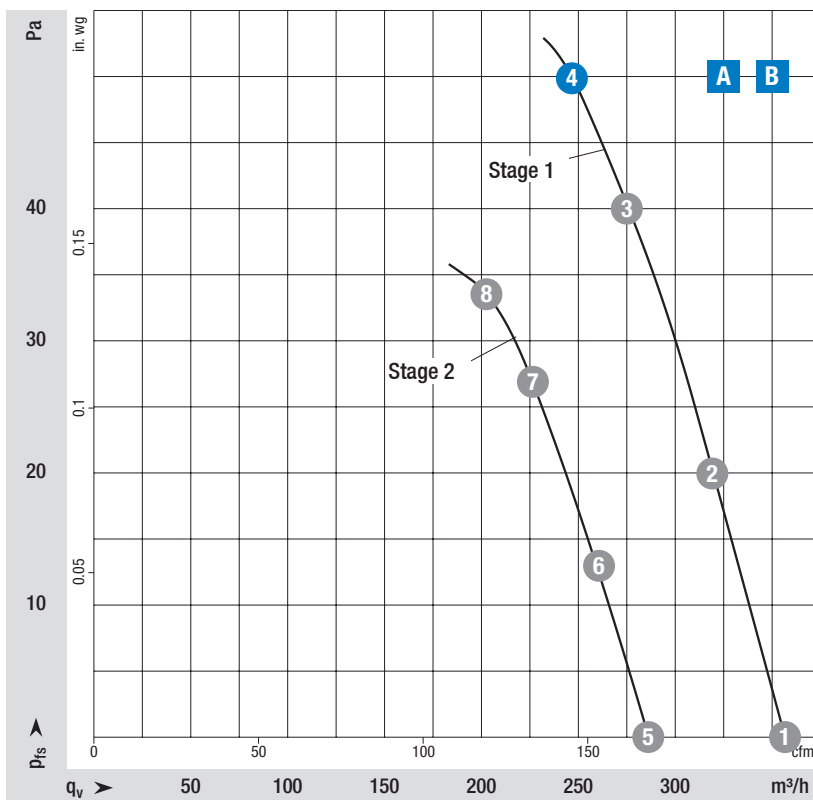

Measuring requirements

Air performance measured according to: ISO 5801, installation category A, in ebm-papst full nozzle without contact protection.
 Intake-side sound level: L_{pA} according to ISO 13347, L_{pA} measured at 1 m distance from fan axis. The values given are only applicable under the specified measuring conditions and may differ depending on the installation conditions. In the event of deviation from the standard configuration, the parameters must be checked in installed condition.

Curve	Operating point	Nominal voltage	Frequency	Speed n	Input power P _{ed}	Input current I	Sound power level L _w /A	Back pressure ⁽¹⁾	Perm. ambient temp.	Conn. diagram
		VAC	Hz	min ⁻¹	W	A	dB(A)	Pa	°C	
Voltage range 200-240 VAC										
A	① Stage 1	230	50/60	2700	11	0.10	57	0	-30...+50	ESM1)
	② Stage 1	230	50/60	2700	13	0.11	57	20		
	③ Stage 1	230	50/60	2700	14	0.12	58	40		
	④ Stage 1	230	50/60	2700	14	0.12	58	50		
	⑤ Stage 2	230	50/60	2200	7	0.07	53	0		
	⑥ Stage 2	230	50/60	2200	8	0.07	52	13		
	⑦ Stage 2	230	50/60	2200	8	0.08	53	27		
	⑧ Stage 2	230	50/60	2200	8	0.08	54	34		
Voltage range 100-240 VAC										
B	① Stage 1	230	50/60	2700	12	0.19	57	0	-30...+50	ESM1)
	② Stage 1	230	50/60	2700	13	0.19	57	20		
	③ Stage 1	230	50/60	2700	14	0.19	58	40		
	④ Stage 1	230	50/60	2700	14	0.19	58	50		
	⑤ Stage 2	230	50/60	2200	7	0.13	53	0		
	⑥ Stage 2	230	50/60	2200	8	0.13	52	13		
	⑦ Stage 2	230	50/60	2200	8	0.13	53	27		
	⑧ Stage 2	230	50/60	2200	9	0.13	54	34		

Values set in blue are nominal data at operating point with maximum load and 230 VAC.

Subject to change. ⁽¹⁾ Max. recommended back pressure before saddle area.

Curve	EC axial fans	
	Part number	Weight
A	W1G154EG5701	0.9 kg
B	W1G154EG5702	0.9 kg

Engineering drawing

Dimensions in mm

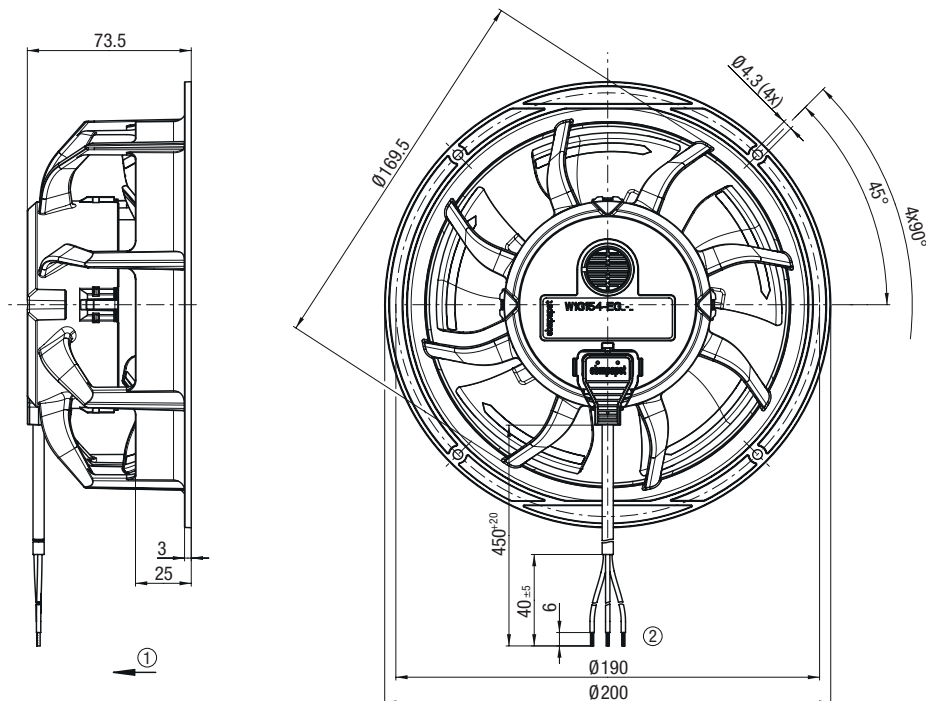

Fan also available with flat-type fan housing (type B). See page 105.

- ① Direction of airflow: "V"
- ② Cable PVC AWG20, 3x splice

EC axial fan

Ø 154 mm, 2 speed levels (not programmable), 100-240 V



Material/surface

- Housing: plastic
- Impeller: plastic

Mechanical data

- Number of blades: 5
- Direction of airflow: blowing over struts ("V")
- Direction of rotation: counter-clockwise viewed toward rotor
- Degree of protection: IP 55
- Insulation class: "B"
- Installation position: any
- Mode: continuous operation (S1)
- Mounting: maintenance-free ball bearings

Electrical data

- Motor protection: electronic
- Electrical hookup: cable for connection on motor side
- Cable exit: lateral
- Protection class: II
- Speed levels: 2 (not programmable)

Standards and approvals

- Conformity with standards: EN 60335-1; EN 60335-2-24; EN 60335-2-80; EN 60335-2-89; CE
- Approvals: UL 1004-7 + 60730; VDE; CSA C22.2 No. 77

on Page 90	Accessories
on Page 108	Connection diagrams and technical features
on Page 120	Technical parameters and scope
More at	www.ebmpapst.com

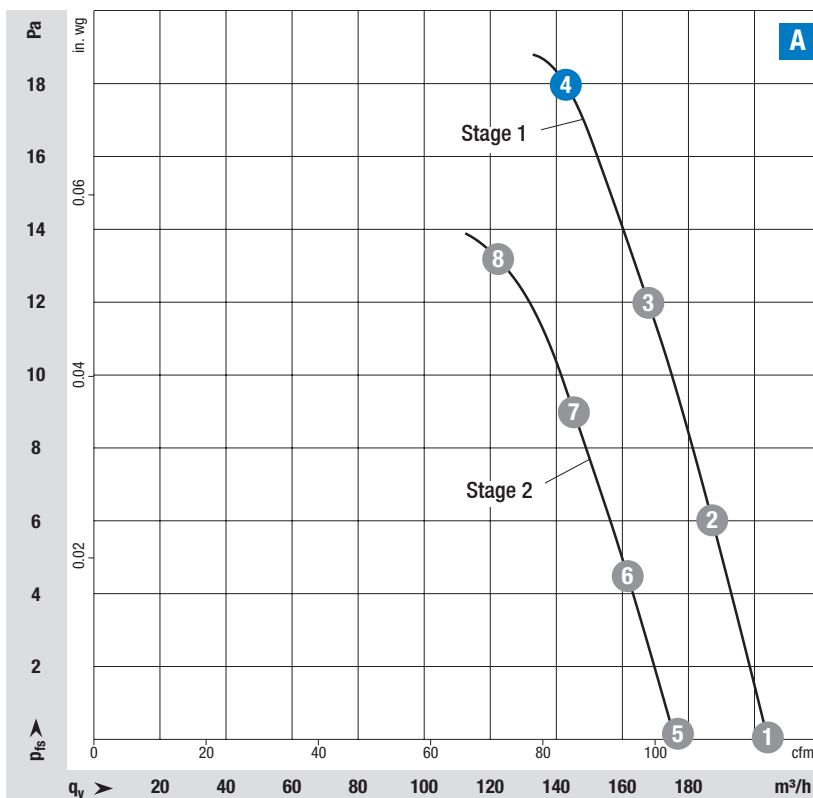

Measuring requirements

Air performance measured according to: ISO 5801, installation category A, in ebm-papst full nozzle without contact protection.
Intake-side sound level: L_{pA} according to ISO 13347, L_{pA} measured at 1 m distance from fan axis. The values given are only applicable under the specified measuring conditions and may differ depending on the installation conditions. In the event of deviation from the standard configuration, the parameters must be checked in installed condition.

Curve	Operating point	Nominal voltage	Frequency	Speed n	Input power P _{ed}	Input current I	Sound power level L _w /A	Back pressure ⁽¹⁾	Perm. ambient temp.	Conn. diagram
		VAC	Hz	min ⁻¹	W	A	dB(A)	Pa	°C	
Voltage range 100-240 VAC										
A	1 Stage 1	115	50/60	1600	9	0.14	54	0	-30...+50	ESM1)
	2 Stage 1	115	50/60	1600	10	0.15	53	10		
	3 Stage 1	115	50/60	1600	10	0.15	52	20		
	4 Stage 1	115	50/60	1600	10	0.16	54	28		
	5 Stage 2	115	50/60	1400	5	0.08	48	0		
	6 Stage 2	115	50/60	1400	5	0.09	47	6		
	7 Stage 2	115	50/60	1400	6	0.09	46	12		
	8 Stage 2	115	50/60	1400	6	0.09	46	18		

Values set in blue are nominal data at operating point with maximum load and 115 VAC.

Subject to change. ⁽¹⁾ Max. recommended back pressure before saddle area.

Curve	EC axial fan	
	Part number	Weight
A	W1G154EG5705	0.9 kg

Engineering drawing

Dimensions in mm

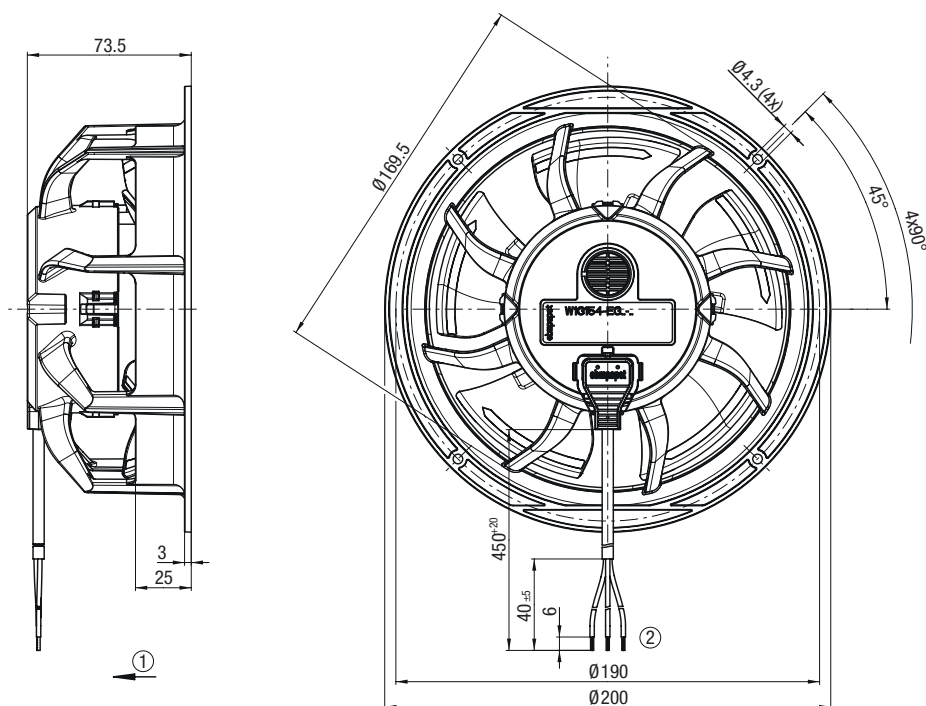

Fan also available with flat-type fan housing (type B). See page 105.

- ① Direction of airflow: "V"
- ② Cable PVC AWG20, 3x splice

EC axial fan

Ø 172 mm, 2 speed levels (not programmable), 100-240 V



Material/surface

- Housing: plastic
- Impeller: plastic

Mechanical data

- Number of blades: 5
- Direction of airflow: blowing over struts ("V")
- Direction of rotation: counter-clockwise viewed toward rotor
- Degree of protection: IP 55
- Insulation class: "B"
- Installation position: any
- Mode: continuous operation (S1)
- Mounting: maintenance-free ball bearings

Electrical data

- Motor protection: thermal overload protector (TOP) internally connected
- Electrical hookup: cable for connection on motor side
- Cable exit: lateral
- Protection class: II
- Speed levels: 2 (not programmable)

Standards and approvals

- Conformity with standards: EN 60335-1; EN 60335-2-24; EN 60335-2-80; EN 60335-2-89; CE; VDE
- Approvals: UL 1004-7 + 60730; CSA C22.2 No. 77; VDE; EAC

on Page 90	Accessories
on Page 108	Connection diagrams and technical features
on Page 120	Technical parameters and scope
More at	www.ebmpapst.com

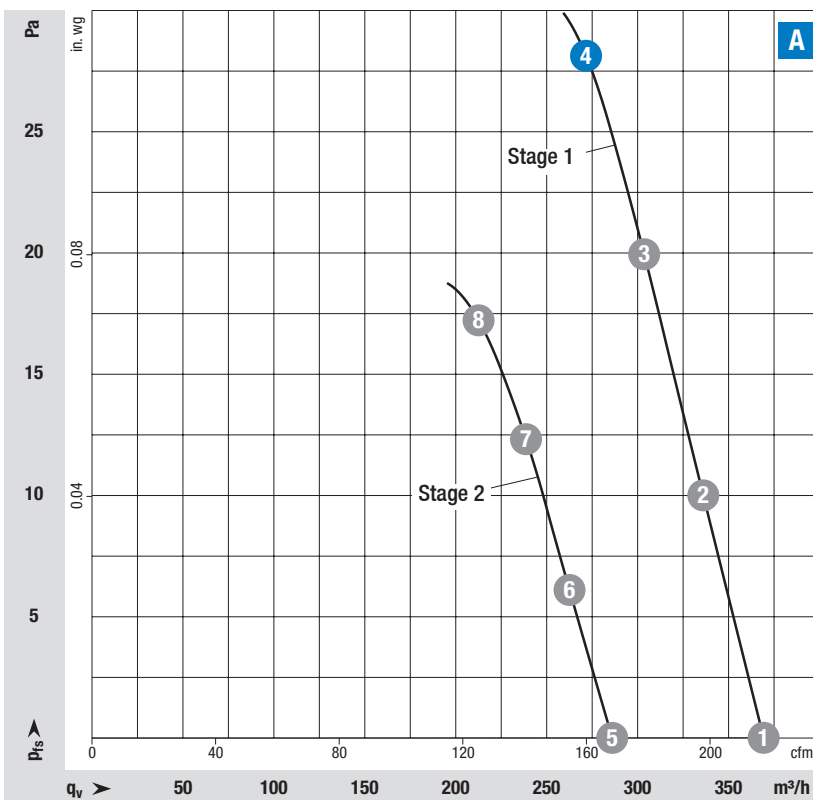

Measuring requirements

Air performance measured according to: ISO 5801, installation category A, in ebm-papst full nozzle without contact protection.
Intake-side sound level: L_{pA} according to ISO 13347, L_{pA} measured at 1 m distance from fan axis. The values given are only applicable under the specified measuring conditions and may differ depending on the installation conditions. In the event of deviation from the standard configuration, the parameters must be checked in installed condition.

Curve	Operating point	Nominal voltage	Frequency	Speed n	Input power P _{ed}	Input current I	Sound power level L _w /A	Back pressure ⁽¹⁾	Perm. ambient temp.	Conn. diagram
		VAC	Hz	min ⁻¹	W	A	dB(A)	Pa	°C	
Voltage range 100-240 VAC										
A	1 Stage 1	115	50/60	1800	9	0.14	54	0	-30...+50	ESM1)
	2 Stage 1	115	50/60	1800	10	0.15	53	10		
	3 Stage 1	115	50/60	1800	10	0.15	52	20		
	4 Stage 1	115	50/60	1800	10	0.16	54	28		
	5 Stage 2	115	50/60	1400	5	0.08	48	0		
	6 Stage 2	115	50/60	1400	5	0.09	47	6		
	7 Stage 2	115	50/60	1400	6	0.09	46	12		
	8 Stage 2	115	50/60	1400	6	0.09	46	18		

Values set in blue are nominal data at operating point with maximum load and 115 VAC.

Subject to change. ⁽¹⁾ Max. recommended back pressure before saddle area.

Curve	EC axial fan	
	Part number	Weight
A	W1G172EC8280	0.9 kg

Engineering drawing

Dimensions in mm

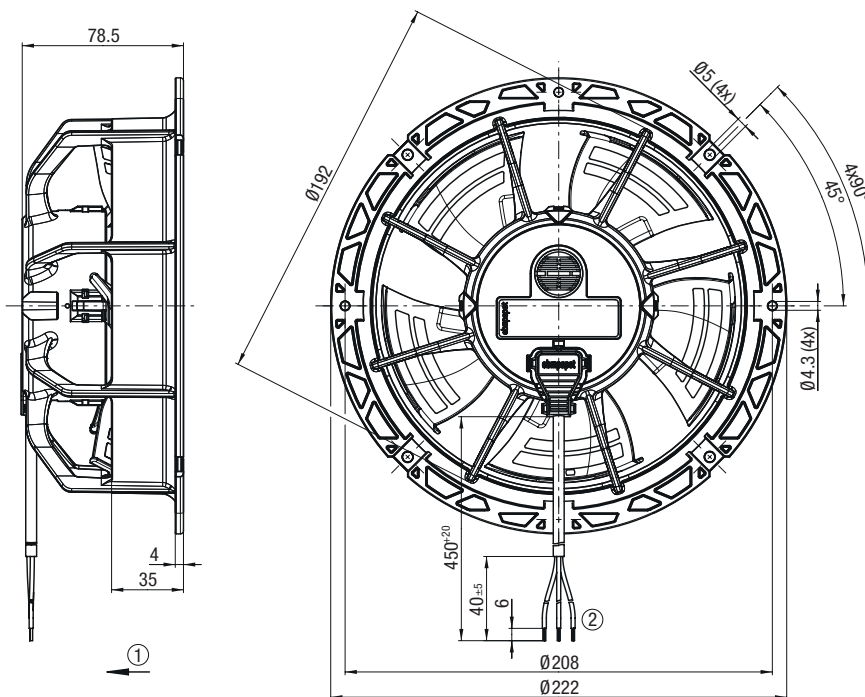

Fan also available with flat-type fan housing (type B). See page 105.

- ① Direction of airflow: "V"
- ② Cable AWG20, 3x crimped splice

EC axial fans

Ø 172 mm, 2 speed levels (programmable)



on Page 90	Accessories
on Page 108	Connection diagrams and technical features
on Page 120	Technical parameters and scope
More at	www.ebmpapst.com

Material/surface

- Housing: plastic
- Impeller: plastic

Mechanical data

- Number of blades: 5
- Direction of airflow: blowing over struts ("V")
- Direction of rotation: counter-clockwise viewed toward rotor
- Degree of protection: IP 55
- Insulation class: "B"
- Installation position: any
- Mode: continuous operation (S1)
- Mounting: maintenance-free ball bearings

Electrical data

- Motor protection: thermal overload protector (TOP) internally connected
- Electrical hookup: cable for connection on motor side
- Cable exit: lateral
- Protection class: II
- Speed levels: 2 (programmable) compatible with plug-in module CCC000-AE**-**

EMC

- Immunity to interference: according to EN 61000-6-2 (industrial environment)
- System disturbance: according to EN 61000-3-2/3
- Interference emission: according to EN 61000-6-3 (household environment)

Standards and approvals

- Conformity with standards: EN 60335-1; EN 60335-2-24; EN 60335-2-80; EN 60335-2-89; CE
- Approvals: UL 1004-3; VDE; EAC; CSA C22.2 No. 77

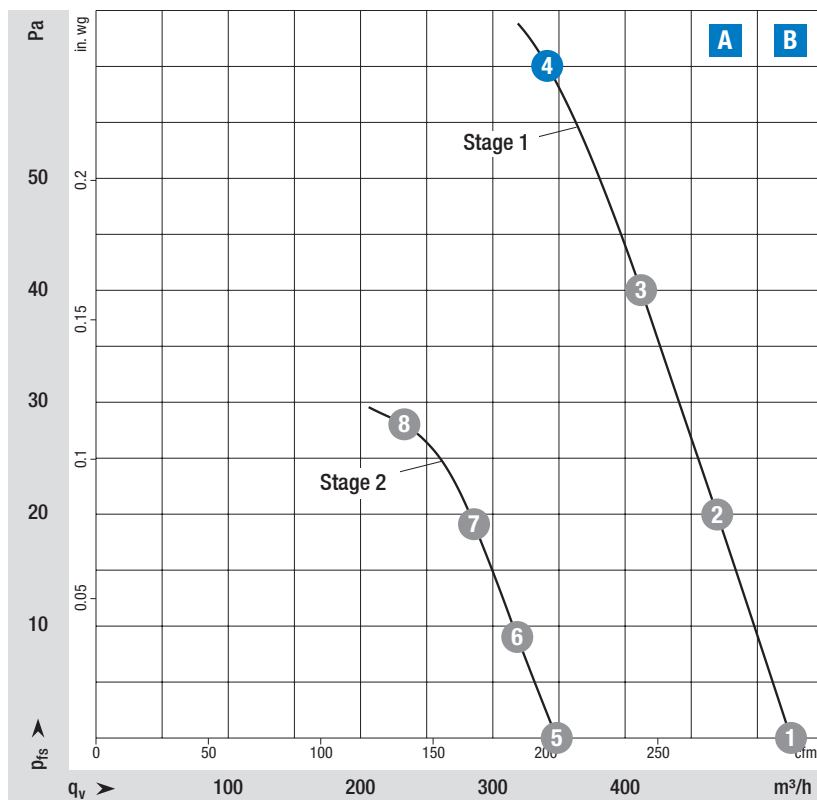

Measuring requirements

Air performance measured according to: ISO 5801, installation category A, in ebm-papst full nozzle without contact protection.
 Intake-side sound level: L_{pA} according to ISO 13347, L_{pA} measured at 1 m distance from fan axis. The values given are only applicable under the specified measuring conditions and may differ depending on the installation conditions. In the event of deviation from the standard configuration, the parameters must be checked in installed condition.

Curve	Operating point	Nominal voltage	Frequency	Speed n	Input power P _{ed}	Input current I	Sound power level L _w /A	Back pressure ⁽¹⁾	Perm. ambient temp.	Conn. diagram
		VAC	Hz	min ⁻¹	W	A	dB(A)	Pa	°C	
Nominal voltage 115 VAC										
A	1 Stage 1	115	50/60	2500	20	0.28	62	0	-30...+50	ESM1)
	2 Stage 1	115	50/60	2500	21	0.30	63	20		
	3 Stage 1	115	50/60	2500	21	0.30	63	40		
	4 Stage 1	115	50/60	2500	21	0.30	63	60		
	5 Stage 2	115	50/60	1700	9	0.14	54	0		
	6 Stage 2	115	50/60	1700	10	0.16	53	10		
	7 Stage 2	115	50/60	1700	11	0.16	53	20		
	8 Stage 2	115	50/60	1700	10	0.16	54	29		
Nominal voltage 230 VAC										
B	1 Stage 1	230	50/60	2500	21	0.17	62	0	-30...+50	ESM1)
	2 Stage 1	230	50/60	2500	22	0.18	63	20		
	3 Stage 1	230	50/60	2500	22	0.18	63	40		
	4 Stage 1	230	50/60	2500	22	0.18	63	60		
	5 Stage 2	230	50/60	1700	9	0.07	54	0		
	6 Stage 2	230	50/60	1700	10	0.08	53	9		
	7 Stage 2	230	50/60	1700	11	0.08	53	19		
	8 Stage 2	230	50/60	1700	10	0.08	54	28		

Values set in blue are nominal data at operating point with maximum load and 115 or 230 VAC.

Subject to change. ⁽¹⁾ Max. recommended back pressure before saddle area.

Curve	EC axial fans	
	Part number	Weight
A	W1G172EC9501	0.9 kg
B	W1G172EC9101	0.9 kg

Engineering drawing

Dimensions in mm

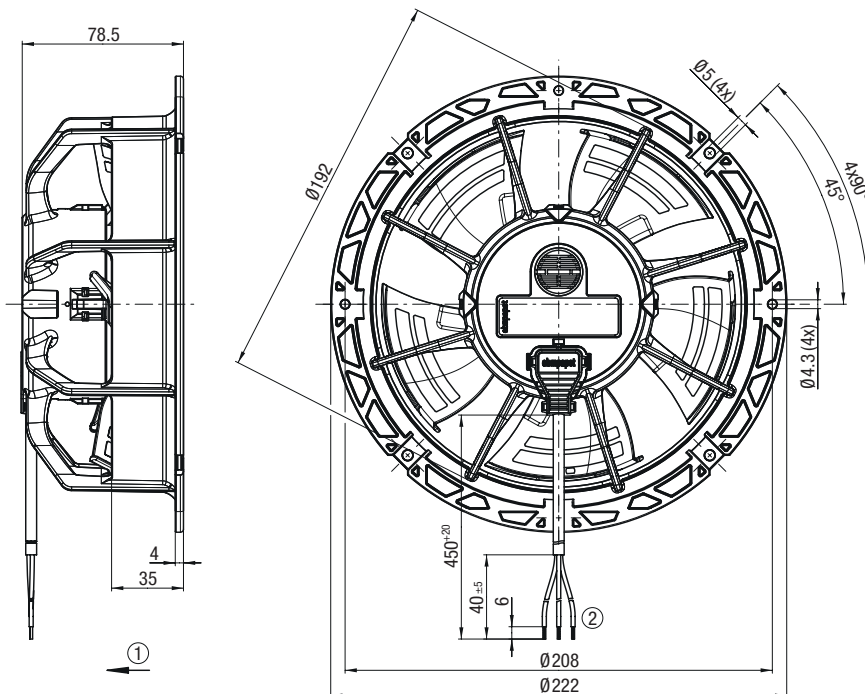

Fan also available with flat-type fan housing (type B). See page 105.

- ① Direction of airflow: "V"
- ② Cable PVC AWG20, 3x crimped splice

EC axial fans

Ø 200 mm, 2 speed levels (not programmable), 100-240 V



Material/surface

- Housing: plastic
- Impeller: plastic

Mechanical data

- Number of blades: 5
- Direction of airflow: blowing over struts ("V")
- Direction of rotation: counter-clockwise viewed toward rotor
- Degree of protection: IP 55
- Insulation class: "B"
- Installation position: any
- Mode: continuous operation (S1)
- Mounting: maintenance-free ball bearings

Electrical data

- Motor protection: electronic
- Electrical hookup: cable for connection on motor side
- Cable exit: lateral
- Protection class: II
- Speed levels: 2 (not programmable)

Standards and approvals

- Conformity with standards: EN 60335-1; EN 60335-2-24; EN 60335-2-80; EN 60335-2-89; CE
- Approvals:
 - A** EAC; VDE
 - B** EAC; VDE; UL 1004-7 + 60730; CSA C22.2 No. 77 + CAN/CSA-E60730-1

on Page 90	Accessories
on Page 108	Connection diagrams and technical features
on Page 120	Technical parameters and scope
More at	www.ebmpapst.com

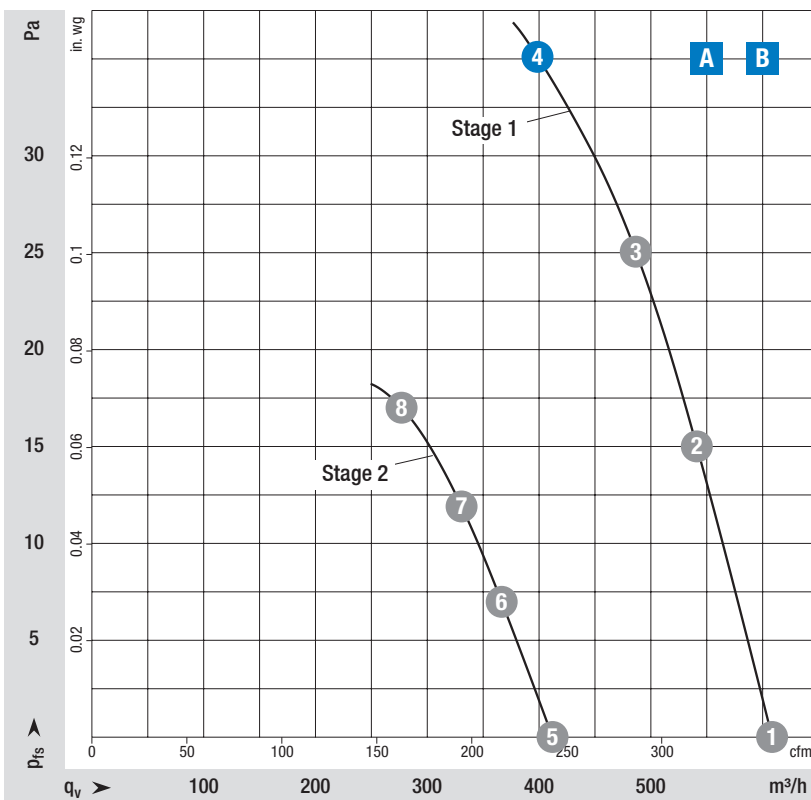

Measuring requirements

Air performance measured according to: ISO 5801, installation category A, in ebm-papst full nozzle without contact protection. Intake-side sound level: L_{pA} according to ISO 13347, L_{pA} measured at 1 m distance from fan axis. The values given are only applicable under the specified measuring conditions and may differ depending on the installation conditions. In the event of deviation from the standard configuration, the parameters must be checked in installed condition.

Curve	Operating point	Nominal voltage	Frequency	Speed n	Input power P _{ed}	Input current I	Sound power level L _{w,A}	Back pressure ⁽¹⁾	Perm. ambient temp.	Conn. diagram
		VAC	Hz	min ⁻¹	W	A	dB(A)	Pa	°C	
Voltage range 200-240 VAC										
A	1 Stage 1	230	50/60	1600	12	0.11	52	0	-25+50	ESM1)
	2 Stage 1	230	50/60	1600	14	0.13	50	15		
	3 Stage 1	230	50/60	1600	15	0.13	50	25		
	4 Stage 1	230	50/60	1600	15	0.13	53	35		
	5 Stage 2	230	50/60	1100	5	0.05	41	0		
	6 Stage 2	230	50/60	1100	5	0.06	39	7		
	7 Stage 2	230	50/60	1100	6	0.06	40	12		
	8 Stage 2	230	50/60	1100	6	0.06	42	17		
Voltage range 100-240 VAC										
B	1 Stage 1	230	50/60	1600	12	0.11	52	0	-30...+50	ESM1)
	2 Stage 1	230	50/60	1600	14	0.13	50	15		
	3 Stage 1	230	50/60	1600	15	0.13	50	25		
	4 Stage 1	230	50/60	1600	15	0.13	53	35		
	5 Stage 2	230	50/60	1100	5	0.05	41	0		
	6 Stage 2	230	50/60	1100	5	0.06	39	7		
	7 Stage 2	230	50/60	1100	6	0.06	40	12		
	8 Stage 2	230	50/60	1100	6	0.06	42	17		

Values set in blue are nominal data at operating point with maximum load and 230 VAC.

Subject to change. ⁽¹⁾Max. recommended back pressure before saddle area.

Curve	EC axial fans	
	Part number	Weight
A	W1G200EG5701	1.0 kg
B	W1G200EG5702	1.0

Engineering drawing

Dimensions in mm

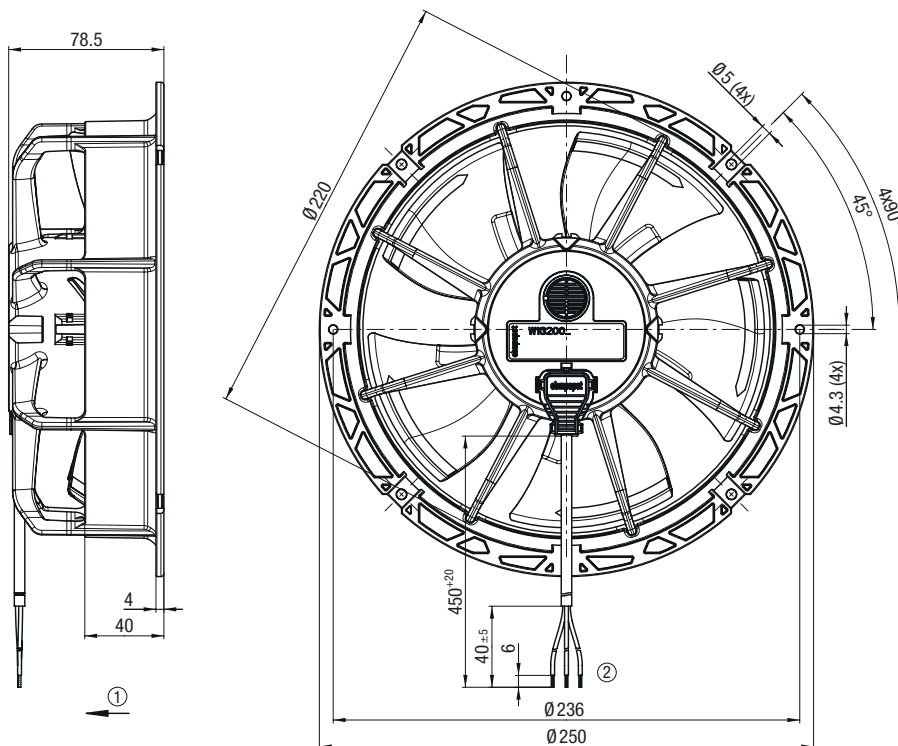

Fan also available with flat-type fan housing (type B). See page 105.

- ① Direction of airflow: "V"
- ② Cable PVC AWG20, 3x splice

EC axial fans

Ø 200 mm, 2 speed levels (not programmable), 100-240 V



Material/surface

- Housing: plastic
- Impeller: plastic

Mechanical data

- Number of blades: 5
- Direction of airflow: blowing over struts ("V")
- Direction of rotation: counter-clockwise viewed toward rotor
- Degree of protection: IP 55
- Insulation class: "B"
- Installation position: any
- Mode: continuous operation (S1)
- Mounting: maintenance-free ball bearings

Electrical data

- Motor protection: electronic
- Electrical hookup: cable for connection on motor side
- Cable exit: lateral
- Protection class: II
- Speed levels: 2 (not programmable)

Standards and approvals

- Conformity with standards: EN 60335-1; EN 60335-2-24; EN 60335-2-80; EN 60335-2-89; CE
- Approvals:
 - A** EAC; VDE
 - B** EAC; VDE; UL 1004-7 + 60730; CSA C22.2 No. 77 + CAN/CSA-E60730-1

on Page 90	Accessories
on Page 108	Connection diagrams and technical features
on Page 120	Technical parameters and scope
More at	www.ebmpapst.com

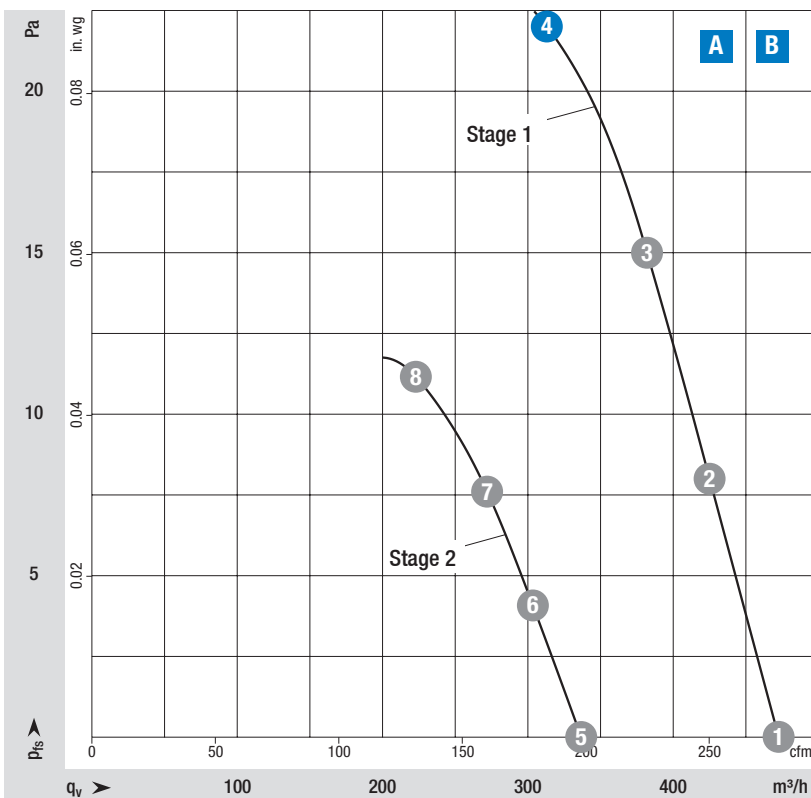

Measuring requirements

Air performance measured according to: ISO 5801, installation category A, in ebm-papst full nozzle without contact protection.
 Intake-side sound level: L_{pA} according to ISO 13347, L_{pA} measured at 1 m distance from fan axis. The values given are only applicable under the specified measuring conditions and may differ depending on the installation conditions. In the event of deviation from the standard configuration, the parameters must be checked in installed condition.

Curve	Operating point	Nominal voltage	Frequency	Speed n	Input power P _{ed}	Input current I	Sound power level L _{w,A}	Back pressure ⁽¹⁾	Perm. ambient temp.	Conn. diagram
		VAC	Hz	min ⁻¹	W	A	dB(A)	Pa	°C	
Voltage range 200-240 VAC										
A	1 Stage 1	230	50/60	1250	7	0.07	46	0	-25...+50	ESM1)
	2 Stage 1	230	50/60	1250	7	0.07	44	8		
	3 Stage 1	230	50/60	1250	8	0.08	44	15		
	4 Stage 1	230	50/60	1250	8	0.08	47	22		
	5 Stage 2	230	50/60	900	3	0.04	38	0		
	6 Stage 2	230	50/60	900	3	0.04	36	4		
	7 Stage 2	230	50/60	900	4	0.04	36	8		
	8 Stage 2	230	50/60	900	4	0.04	40	11		
Voltage range 100-240 VAC										
B	1 Stage 1	230	50/60	1250	7	0.07	46	0	-30...+50	ESM1)
	2 Stage 1	230	50/60	1250	7	0.07	44	8		
	3 Stage 1	230	50/60	1250	8	0.08	45	15		
	4 Stage 1	230	50/60	1250	8	0.08	49	22		
	5 Stage 2	230	50/60	900	3	0.04	38	0		
	6 Stage 2	230	50/60	900	3	0.04	36	4		
	7 Stage 2	230	50/60	900	4	0.04	37	8		
	8 Stage 2	230	50/60	900	4	0.04	41	11		

Values set in blue are nominal data at operating point with maximum load and 230 VAC.

Subject to change. ⁽¹⁾Max. recommended back pressure before saddle area.

Curve	EC axial fans	
	Part number	Weight
A	W1G200EG5704	1.0 kg
B	W1G200EG5705	1.0

Engineering drawing

Dimensions in mm

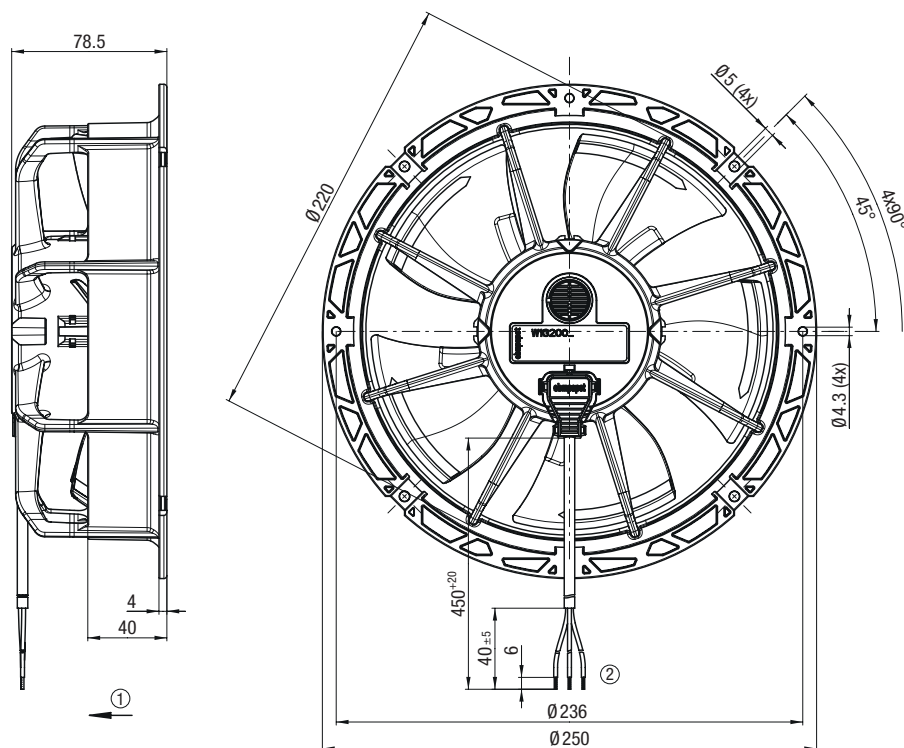

Fan also available with flat-type fan housing (type B). See page 105.

- ① Direction of airflow: "V"
- ② Cable PVC AWG20, 3x splice

EC axial fans

Ø 200 mm, 2 speed levels (programmable)



on Page 90	Accessories
on Page 108	Connection diagrams and technical features
on Page 120	Technical parameters and scope
More at	www.ebmpapst.com

Material/surface

- Housing: plastic
- Impeller: plastic

Mechanical data

- Number of blades: 5
- Direction of airflow: blowing over struts ("V")
- Direction of rotation: counter-clockwise viewed toward rotor
- Degree of protection: IP 55
- Insulation class: "B"
- Installation position: any
- Mode: continuous operation (S1)
- Mounting: maintenance-free ball bearings

Electrical data

- Motor protection: thermal overload protector (TOP) internally connected
- Electrical hookup: cable for connection on motor side
- Cable exit: lateral
- Protection class: II
- Speed levels: 2 (programmable) compatible with plug-in module CCC000-AE**.-**

EMC

- Immunity to interference: according to EN 61000-6-2 (industrial environment)
- System disturbance: according to EN 61000-3-2/3
- Interference emission: according to EN 61000-6-3 (household environment)

Standards and approvals

- Conformity with standards: EN 60335-1; EN 60335-2-24; EN 60335-2-80; EN 60335-2-89; CE
- Approvals: UL 1004-3; VDE; EAC; CSA C22.2 No. 77; CCC

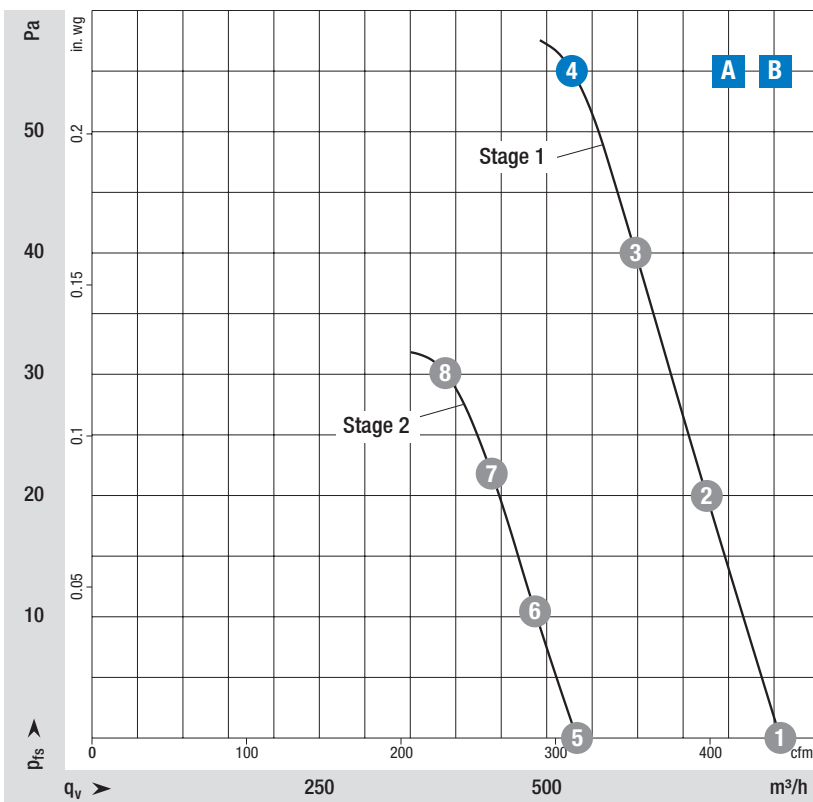

Measuring requirements

Air performance measured according to: ISO 5801, installation category A, in ebm-papst full nozzle without contact protection.
Intake-side sound level: L_{pA} according to ISO 13347, L_{pA} measured at 1 m distance from fan axis. The values given are only applicable under the specified measuring conditions and may differ depending on the installation conditions. In the event of deviation from the standard configuration, the parameters must be checked in installed condition.

Curve	Operating point	Nominal voltage	Frequency	Speed n	Input power P _{ed}	Input current I	Sound power level L _w /A	Back pressure ⁽¹⁾	Perm. ambient temp.	Conn. diagram
		VAC	Hz	min ⁻¹	W	A	dB(A)	Pa	°C	
Nominal voltage 115 VAC										
A	① Stage 1	115	50/60	2100	28	0.42	62	0	-30...+50	ESM1)
	② Stage 1	115	50/60	2100	30	0.45	61	20		
	③ Stage 1	115	50/60	2100	31	0.46	60	40		
	④ Stage 1	115	50/60	2100	31	0.46	62	55		
	⑤ Stage 2	115	50/60	1500	14	0.22	54	0		
	⑥ Stage 2	115	50/60	1500	15	0.22	54	10		
	⑦ Stage 2	115	50/60	1500	16	0.25	53	22		
	⑧ Stage 2	115	50/60	1500	17	0.26	55	31		
Nominal voltage 230 VAC										
B	① Stage 1	230	50/60	2100	29	0.22	62	0	-30...+50	ESM1)
	② Stage 1	230	50/60	2100	30	0.23	61	20		
	③ Stage 1	230	50/60	2100	31	0.24	60	40		
	④ Stage 1	230	50/60	2100	31	0.24	62	55		
	⑤ Stage 2	230	50/60	1500	14	0.11	54	0		
	⑥ Stage 2	230	50/60	1500	15	0.12	54	10		
	⑦ Stage 2	230	50/60	1500	15	0.12	53	21		
	⑧ Stage 2	230	50/60	1500	15	0.12	55	29		

Values set in blue are nominal data at operating point with maximum load and 115 or 230 VAC.

Subject to change. ⁽¹⁾Max. recommended back pressure before saddle area.

Curve	EC axial fans	
	Part number	Weight
A	W1G200EC9547	0.9 kg
B	W1G200EC9145	0.9 kg

Engineering drawing

Dimensions in mm

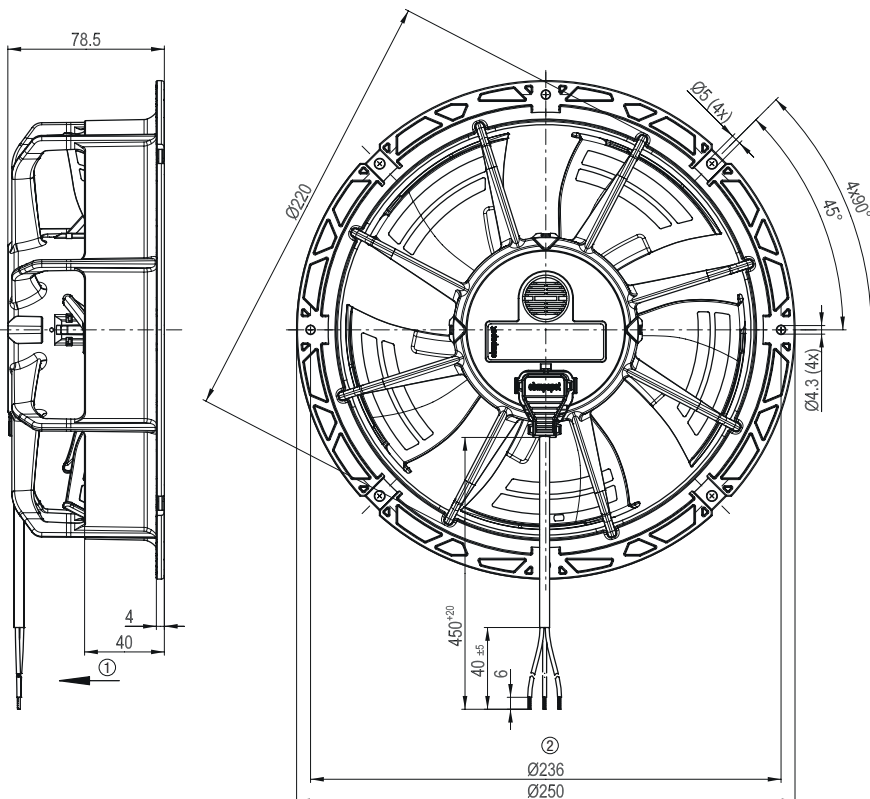

Fan also available with flat-type fan housing (type B). See page 105.

- ① Direction of airflow: "V"
- ② Cable PVC AWG20, 3x crimped splice

EC axial fans

Ø 200 mm, infinitely variable speed control



on Page 90	Accessories
on Page 108	Connection diagrams and technical features
on Page 120	Technical parameters and scope
More at	www.ebmpapst.com

Material/surface

- Housing: plastic
- Impeller: plastic
- Plug-in module: plastic

Mechanical data

- Number of blades: 5
- Direction of airflow: blowing over struts ("V")
- Direction of rotation: counter-clockwise viewed toward rotor
- Degree of protection: IP 55
- Insulation class: "B"
- Installation position: any
- Mode: continuous operation (S1)
- Mounting: maintenance-free ball bearings

Electrical data

- Motor protection: thermal overload protector (TOP) internally connected
- Electrical hookup: cable for connection on motor side
- Cable exit: lateral
- Protection class: II
- Speed levels: with infinitely variable control 50-100 %; η_{max} programmable with CBC000-AF08-01

EMC

- Immunity to interference: according to EN 61000-6-2 (industrial environment)
- System disturbance: according to EN 61000-3-2/3
- Interference emission: according to EN 61000-6-3 (household environment)

Standards and approvals

- Conformity with standards: EN 60335-1; EN 60335-2-24; EN 60335-2-80; EN 60335-2-89; CE
- Approvals: UL 1004-3; EAC; VDE; CSA C22.2 No. 77

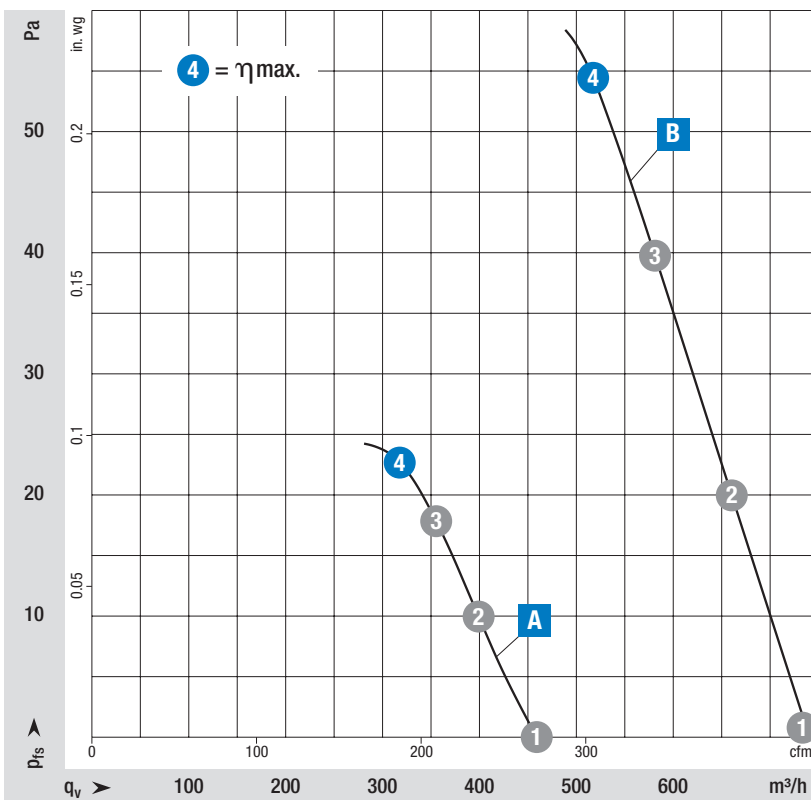

Measuring requirements

Air performance measured according to: ISO 5801, installation category A, in ebm-papst full nozzle without contact protection. Intake-side sound level: L_{pA} according to ISO 13347, L_{pA} measured at 1 m distance from fan axis. The values given are only applicable under the specified measuring conditions and may differ depending on the installation conditions. In the event of deviation from the standard configuration, the parameters must be checked in installed condition.

Curve	Operating point	Nominal voltage	Frequency	Speed n	Input power P _{ed}	Input current I	Sound power level L _w /A	Back pressure ⁽¹⁾	Perm. ambient temp.	Conn. diagram
		VAC	Hz	min ⁻¹	W	A	dB(A)	Pa	°C	
Nominal voltage 230 VAC										
A	①	230	50/60	1300	8	0.07	50	0	-30...+50	ESM4)
	②	230	50/60	1300	8	0.07	49	10		
	③	230	50/60	1300	8	0.07	48	18		
	④	230	50/60	1300	8	0.07	48	23		
B	①	230	50/60	2100	29	0.23	62	0	-30...+50	ESM4)
	②	230	50/60	2100	30	0.24	62	20		
	③	230	50/60	2100	31	0.24	60	40		
	④	230	50/60	2100	31	0.24	59	55		

Values set in blue are nominal data at operating point with maximum load and 230 VAC.

Subject to change. ⁽¹⁾ Max. recommended back pressure before saddle area.

Curve	EC axial fans	
	Part number	Weight
A	W1G200EC87A2	1.0 kg
B	W1G200EC91A4	1.0 kg

Engineering drawing

Dimensions in mm

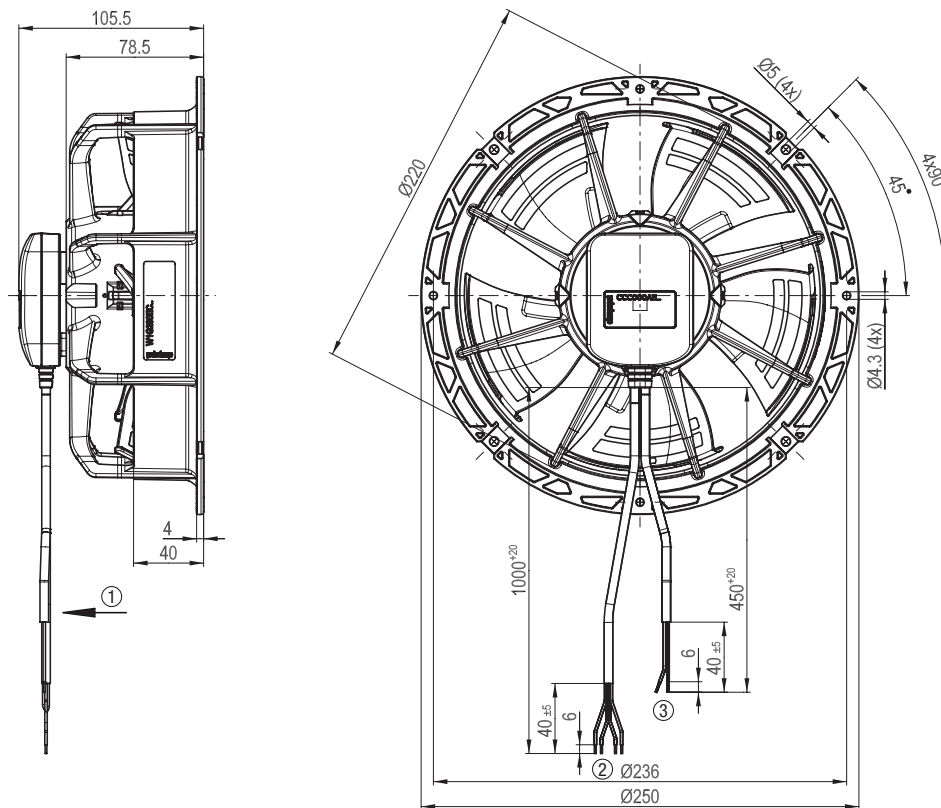

Fan also available with flat-type fan housing (type B). See page 105.

- ① Direction of airflow: "V"
- ② Cable PVC AWG22, 4x splice
- ③ Cable PVC AWG22, 2x splice

EC axial fans

Ø 200 mm, 2 speed levels (not programmable)



Axial fans

on Page 90	Accessories
on Page 108	Connection diagrams and technical features
on Page 120	Technical parameters and scope
More at	www.ebmpapst.com

Material/surface

- Housing: plastic
- Impeller: plastic

Mechanical data

- Number of blades: 5
- Direction of airflow: blowing over struts ("V")
- Direction of rotation: counter-clockwise viewed toward rotor
- Degree of protection: IP 54
- Insulation class: "B"
- Installation position: any
- Mode: continuous operation (S1)
- Mounting: maintenance-free ball bearings

Electrical data

- Motor protection: thermal overload protector (TOP) internally connected
- Electrical hookup: cable for connection on motor side
- Cable exit: lateral
- Protection class: II
- Speed levels: 2 (not programmable)

EMC

- Immunity to interference:
 - **B** according to EN 61000-6-2 (industrial environment)
- Interference emission:
 - **B** according to EN 61000-6-3 (household environment)
- System disturbance:
 - **B** according to EN 61000-3-2/3

Standards and approvals

- Conformity with standards: EN 60335-1; EN 60335-2-89; 3G; CE; VDE
- Approvals: VDE; CSA C22.2 Nr.77; UL 1004-3; 3G; II 3G nA IIA T4

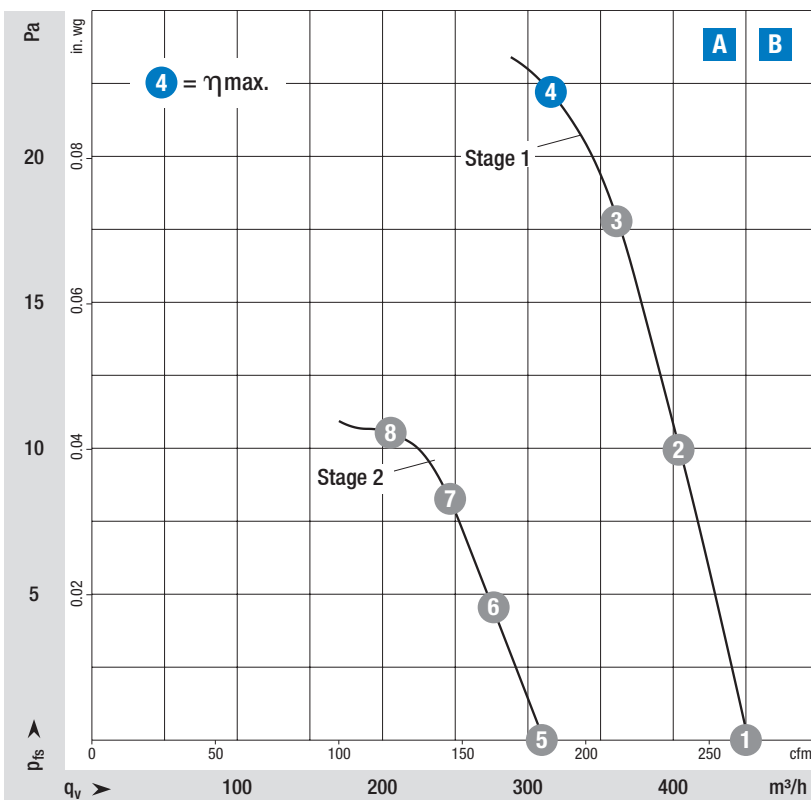

Measuring requirements
 Air performance measured according to: ISO 5801, installation category A, in ebm-papst full nozzle without contact protection.
 Intake-side sound level: L_{pA} according to ISO 13347, L_pA measured at 1 m distance from fan axis. The values given are only applicable under the specified measuring conditions and may differ depending on the installation conditions. In the event of deviation from the standard configuration, the parameters must be checked in installed condition.

Curve	Operating point	Nominal voltage	Frequency	Speed n	Input power P _{ed}	Input current I	Sound power level L _w /A	Back pressure ⁽¹⁾	Perm. ambient temp.	Conn. diagram
		VAC	Hz	min ⁻¹	W	A	dB(A)	Pa	°C	
Nominal voltage 115 VAC										
A	1 Stage 1	115	50/60	1300	6.9	0.09	50	0	-30...+40	ESM1)
	2 Stage 1	115	50/60	1300	7.7	0.10	49	10		
	3 Stage 1	115	50/60	1300	7.9	0.10	48	18		
	4 Stage 1	115	50/60	1300	8.0	0.11	50	23		
	5 Stage 2	115	50/60	900	3.0	0.05	41	0		
	6 Stage 2	115	50/60	900	4.0	0.05	41	5		
	7 Stage 2	115	50/60	900	4.0	0.05	41	9		
	8 Stage 2	115	50/60	900	4.0	0.05	41	10		
Nominal voltage 230 VAC										
B	1 Stage 1	230	50/60	1300	7.0	0.06	50	0	-30...+40	ESM1)
	2 Stage 1	230	50/60	1300	8.0	0.07	49	10		
	3 Stage 1	230	50/60	1300	8.0	0.07	48	18		
	4 Stage 1	230	50/60	1300	8.0	0.07	51	23		
	5 Stage 2	230	50/60	900	3.4	0.03	41	0		
	6 Stage 2	230	50/60	900	4.0	0.04	41	5		
	7 Stage 2	230	50/60	900	4.1	0.04	40	8		
	8 Stage 2	230	50/60	900	4.0	0.04	41	11		

Values set in blue are nominal data at operating point with maximum load and 115 or 230 VAC.

Subject to change. ⁽¹⁾Max. recommended back pressure before saddle area.

Curve	EC axial fans	
	Part number	Weight
A	W1G200EX9103	1.0 kg
B	W1G200EX8703	1.0 kg

Engineering drawing

Dimensions in mm

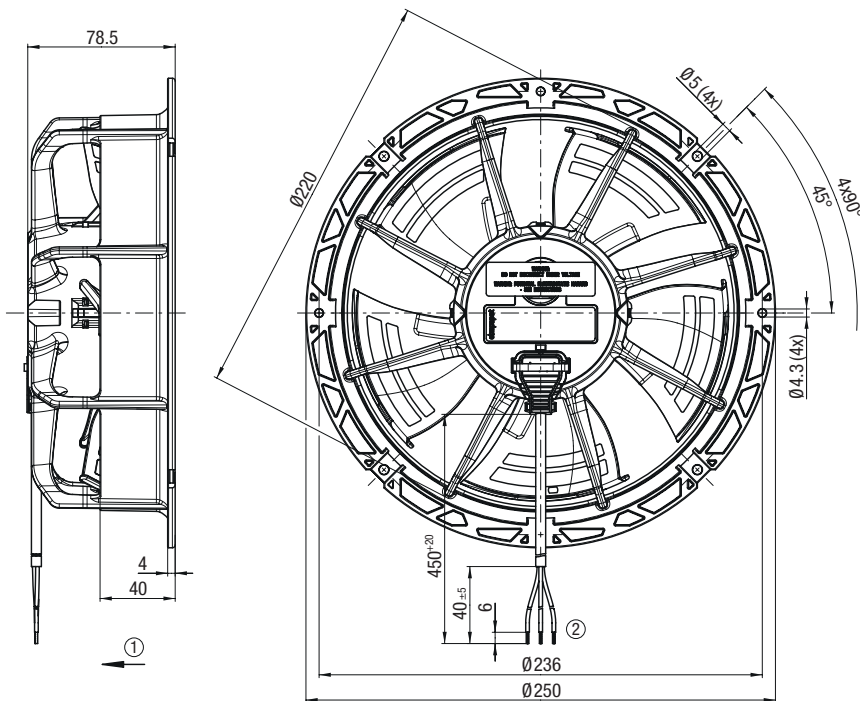

Fan also available with flat-type fan housing (type B). See page 105.

- ① Direction of airflow: "V"
- ② Cable PVC AWG20, 3x splice

EC axial fans

Ø 200 mm, 2 speed levels (not programmable)



Axial fans

on Page 90	Accessories
on Page 108	Connection diagrams and technical features
on Page 120	Technical parameters and scope
More at	www.ebmpapst.com

Material/surface

- Housing: plastic
- Impeller: plastic

Mechanical data

- Number of blades: 5
- Direction of airflow: blowing over struts ("V")
- Direction of rotation: counter-clockwise viewed toward rotor
- Degree of protection: IP 54
- Insulation class: "B"
- Installation position: any
- Mode: continuous operation (S1)
- Mounting: maintenance-free ball bearings

Electrical data

- Motor protection: thermal overload protector (TOP) internally connected
- Electrical hookup: cable for connection on motor side
- Cable exit: lateral
- Protection class: II
- Speed levels: 2 (not programmable)

EMC

- Immunity to interference:
 - **B** according to EN 61000-6-2 (industrial environment)
- Interference emission:
 - **B** according to EN 61000-6-3 (household environment)
- System disturbance:
 - **B** according to EN 61000-3-2/3

Standards and approvals

- Conformity with standards: EN 60335-1; EN 60335-2-89; 3G; CE
- Approvals: VDE; CSA C22.2 Nr.77; UL 1004-3; 3G; II 3G nA IIA T4

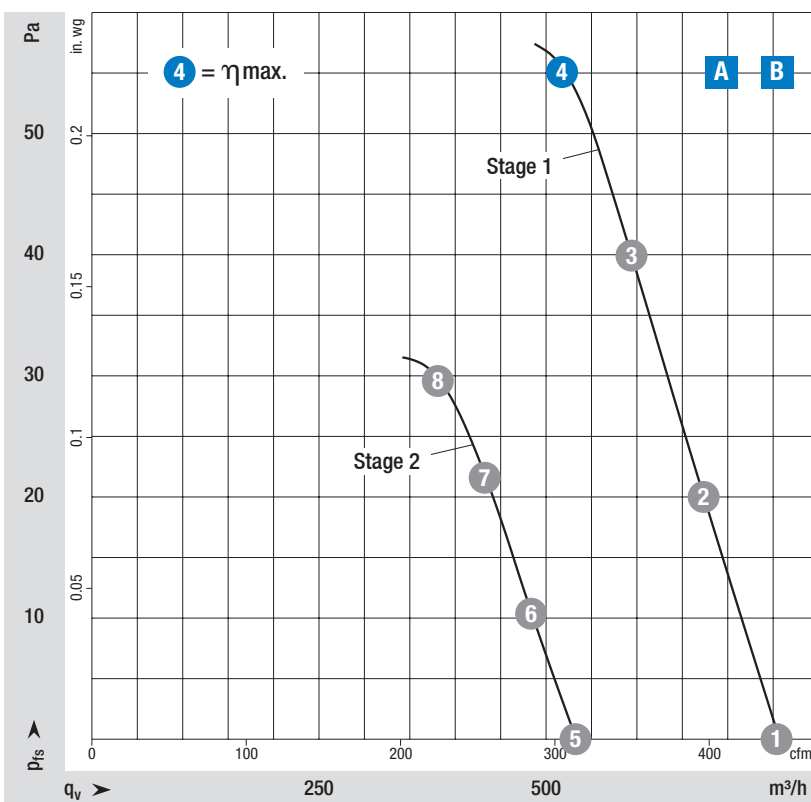

Measuring requirements

Air performance measured according to: ISO 5801, installation category A, in ebm-papst full nozzle without contact protection.
 Intake-side sound level: L_{pA} according to ISO 13347, L_{pA} measured at 1 m distance from fan axis. The values given are only applicable under the specified measuring conditions and may differ depending on the installation conditions. In the event of deviation from the standard configuration, the parameters must be checked in installed condition.

Curve	Operating point	Nominal voltage	Frequency	Speed n	Input power P _{ed}	Input current I	Sound power level L _w /A	Back pressure ⁽¹⁾	Perm. ambient temp.	Conn. diagram
		VAC	Hz	min ⁻¹	W	A	dB(A)	Pa	°C	
Nominal voltage 115 VAC										
A	1 Stage 1	115	50/60	2100	28	0.42	62	0	-30...+40	ESM1)
	2 Stage 1	115	50/60	2100	30	0.45	62	20		
	3 Stage 1	115	50/60	2100	31	0.46	60	40		
	4 Stage 1	115	50/60	2100	31	0.46	60	55		
	5 Stage 2	115	50/60	1500	14	0.22	54	0		
	6 Stage 2	115	50/60	1500	15	0.22	54	10		
	7 Stage 2	115	50/60	1500	16	0.25	53	22		
	8 Stage 2	115	50/60	1500	17	0.26	53	31		
Nominal voltage 230 VAC										
B	1 Stage 1	230	50/60	2100	29	0.22	62	0	-30...+40	ESM1)
	2 Stage 1	230	50/60	2100	30	0.23	61	20		
	3 Stage 1	230	50/60	2100	31	0.24	60	40		
	4 Stage 1	230	50/60	2100	31	0.24	64	55		
	5 Stage 2	230	50/60	1500	14	0.11	54	0		
	6 Stage 2	230	50/60	1500	15	0.12	54	10		
	7 Stage 2	230	50/60	1500	15	0.12	53	21		
	8 Stage 2	230	50/60	1500	15	0.12	56	29		

Values set in blue are nominal data at operating point with maximum load and 115 or 230 VAC.

Subject to change. ⁽¹⁾Max. recommended back pressure before saddle area.

Curve	EC axial fans	
	Part number	Weight
A	W1G200EX9501	1.0 kg
B	W1G200EX9101	1.0

Engineering drawing

Dimensions in mm

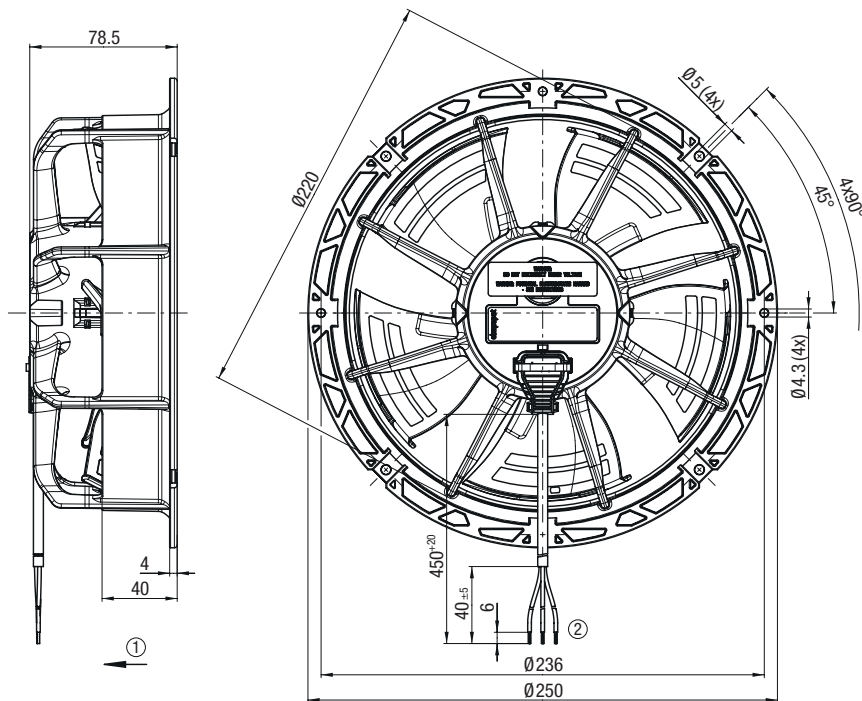

Fan also available with flat-type fan housing (type B). See page 105.

- ① Direction of airflow: "V"
- ② Cable PVC 3X AWG20, 3x crimped splice

DC axial fans

Ø 200 mm, infinitely variable speed control



on Page 90	Accessories
on Page 108	Connection diagrams and technical features
on Page 120	Technical parameters and scope
More at	www.ebmpapst.com

Material/surface

- Housing: plastic
- Impeller: plastic

Mechanical data

- Number of blades: 5
- Direction of airflow: blowing over struts ("V")
- Direction of rotation: counter-clockwise viewed toward rotor
- Degree of protection: IP 55
- Insulation class: "B"
- Installation position: any
- Mode: continuous operation (S1)
- Mounting: maintenance-free ball bearings

Electrical data

- Motor protection: thermal overload protector (TOP) internally connected
- Electrical hookup: cable for connection on motor side
- Cable exit: lateral
- Protection class: II
- Speed levels: with infinitely variable control

Standards and approvals

- Conformity with standards: EN 60335-1; EN 60335-2-24; EN 60335-2-80; EN 60335-2-89
- Approvals: UL 1004-3; VDE; EAC; CSA C22.2 No. 77

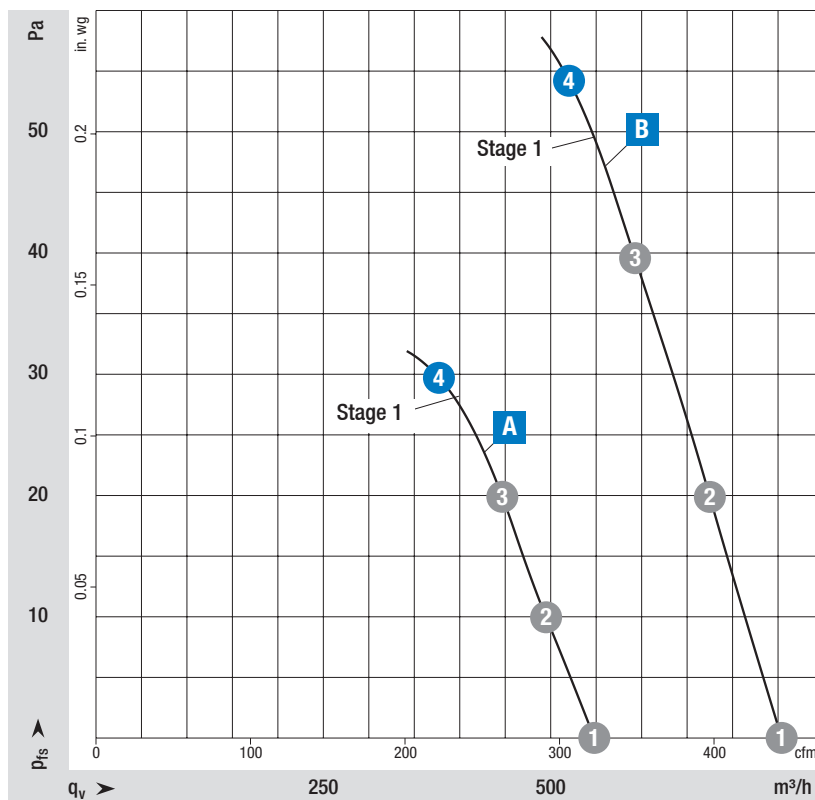

Measuring requirements

Air performance measured according to: ISO 5801, installation category A, in ebm-papst full nozzle without contact protection. Intake-side sound level: L_{pA} according to ISO 13347, L_pA measured at 1 m distance from fan axis. The values given are only applicable under the specified measuring conditions and may differ depending on the installation conditions. In the event of deviation from the standard configuration, the parameters must be checked in installed condition.

Curve	Operating point	Nominal voltage	Speed n	Input power P _{ed}	Input current I	Sound power level L _w /A	Back pressure ⁽³⁾	Perm. ambient temp.	Conn. diagram
		VDC	min ⁻¹	W	A	dB(A)	Pa	°C	
Voltage range 16-28 VDC									
A	① Stage 1	24	1550	11	0.50	54	0	-30...+50	ESM3)
	② Stage 1	24	1530	11	0.50	53	10		
	③ Stage 1	24	1510	11	0.51	52	20		
	④ Stage 1	24	1515	11	0.51	55	30		
B	① Stage 1	24	2130	29	1.50	62	0	-30...+50	ESM3)
	② Stage 1	24	2085	30	1.56	62	20		
	③ Stage 1	24	2050	31	1.61	61	40		
	④ Stage 1	24	2050	31	1.62	59	55		

Values set in blue are nominal data at operating point with maximum load and 24 VDC.

Subject to change. ⁽³⁾Max. recommended back pressure before saddle area.

Curve	DC axial fans	
	Part number	Weight
A	W1G200EF4101 ⁽²⁾	0.9 kg
B	W1G200EF0101	0.9 kg

⁽²⁾ With control input 0-10 VDC / PWM

Engineering drawing

Dimensions in mm

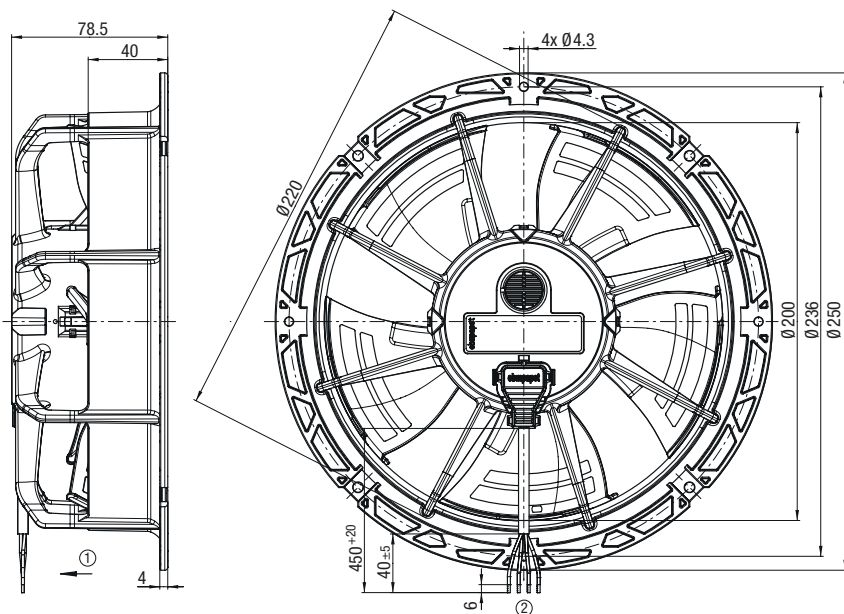

Fan also available with flat-type fan housing (type B). See page 105.

- ① Direction of airflow: "V"
- ② Cable PVC AWG20, 4x splice

DC axial fan

Ø 200 mm, infinitely variable speed control, MODBUS interface



Material/surface

- Housing: plastic
- Impeller: plastic

Mechanical data

- Number of blades: 5
- Direction of airflow: blowing over struts ("V")
- Direction of rotation: counter-clockwise viewed toward rotor
- Degree of protection: IP 55
- Insulation class: "B"
- Installation position: any
- Mode: continuous operation (S1)
- Mounting: maintenance-free ball bearings

Electrical data

- Motor protection: thermal overload protector (TOP) internally connected
- Electrical hookup: cable for connection on motor side
- Cable exit: lateral
- Protection class: II
- Speed levels: with infinitely variable control via RS485 MODBUS-RTU, alternatively 3-stage (manual switching)

Standards and approvals

- Conformity with standards: EN 60335-1; EN 60335-2-24; EN 60335-2-80; EN 60335-2-89
- Approvals: UL 1004-3; EAC; CSA C22.2 No. 77

on Page 90	Accessories
on Page 108	Connection diagrams and technical features
on Page 120	Technical parameters and scope
More at	www.ebmpapst.com

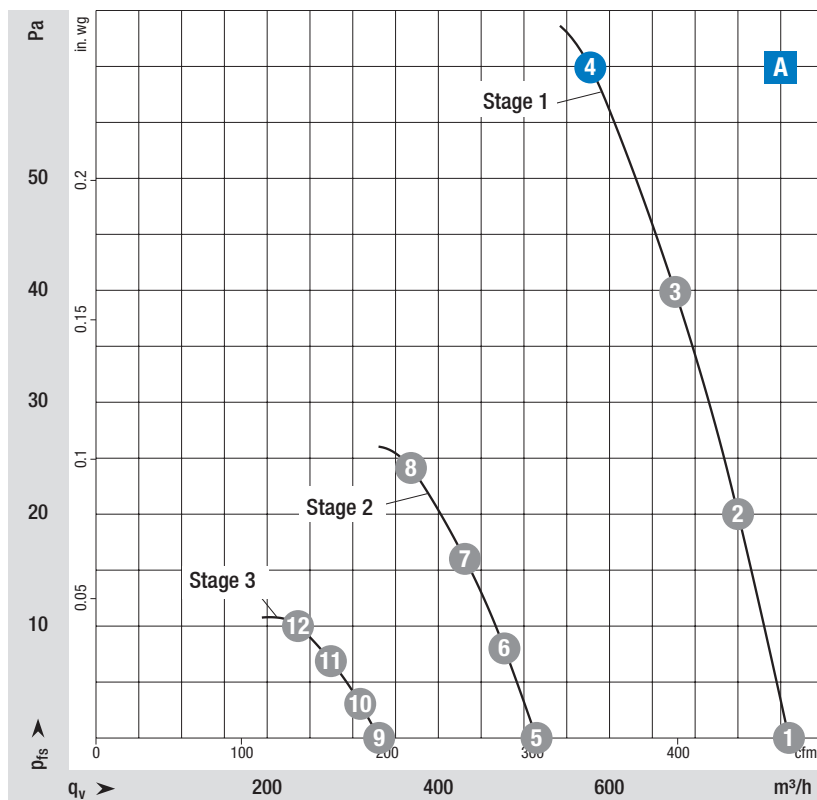

Measuring requirements

Air performance measured according to: ISO 5801, installation category A, in ebm-papst full nozzle without contact protection.
Intake-side sound level: L_{pA} according to ISO 13347, L_{pA} measured at 1 m distance from fan axis. The values given are only applicable under the specified measuring conditions and may differ depending on the installation conditions. In the event of deviation from the standard configuration, the parameters must be checked in installed condition.

Curve	Operating point	Nominal voltage	Speed n	Input power P _{ed}	Input current I	Sound power level L _{WA}	Back pressure ⁽¹⁾	Perm. ambient temp.	Conn. diagram
		VDC	min ⁻¹	W	A	dB(A)	Pa	°C	
Voltage range 16-28 VDC									
A	① Stage 1	24	2200	29	1.31	64	0	-30...+50	ESM2)
	② Stage 1	24	2200	31	1.45	64	20		
	③ Stage 1	24	2200	33	1.57	63	40		
	④ Stage 1	24	2200	35	1.60	64	60		
	⑤ Stage 2	24	1400	7	0.34	52	0		
	⑥ Stage 2	24	1400	8	0.37	52	8		
	⑦ Stage 2	24	1400	9	0.40	52	16		
	⑧ Stage 2	24	1400	9	0.42	53	24		
	⑨ Stage 3	24	900	2	0.09	41	0		
	⑩ Stage 3	24	900	2	0.10	41	3		
	⑪ Stage 3	24	900	2	0.11	41	7		
	⑫ Stage 3	24	900	2	0.11	42	10		

Values set in blue are nominal data at operating point with maximum load and 24 VDC.

Subject to change. ⁽¹⁾ Max. recommended back pressure before saddle area.

Curve	DC-Axialventilator	
	Part number	Weight
A	W1G200EF6002	0.9 kg

Engineering drawing

Dimensions in mm

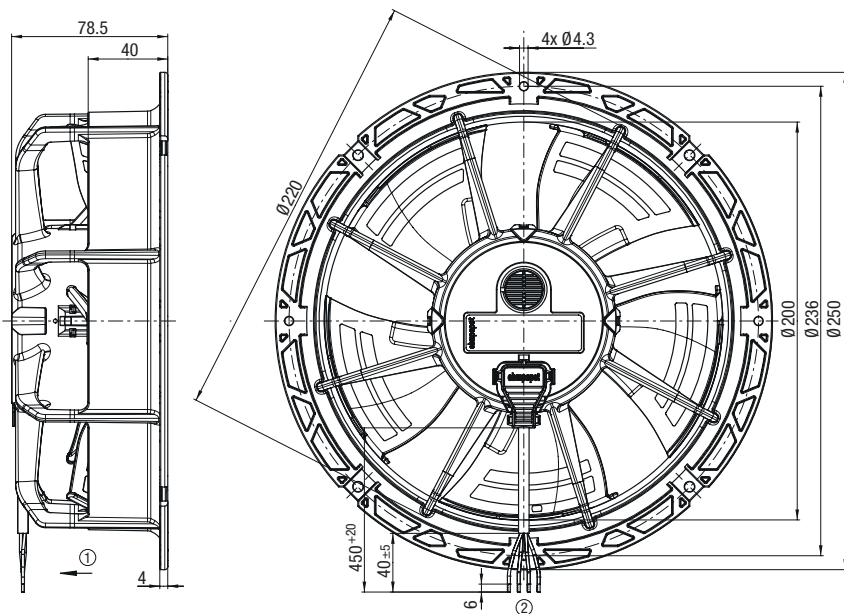

Fan also available with flat-type fan housing (type B). See page 105.

- ① Direction of airflow: "V"
- ② Cable PVC AWG20, 4x crimped splice

EC axial fans

Ø 230 mm, 2 speed levels (programmable)



on Page 90	Accessories
on Page 108	Connection diagrams and technical features
on Page 120	Technical parameters and scope
More at	www.ebmpapst.com

Material/surface

- Housing: plastic
- Impeller: plastic

Mechanical data

- Number of blades: 5
- Direction of airflow: blowing over struts ("V")
- Direction of rotation: counter-clockwise viewed toward rotor
- Degree of protection: IP 55
- Insulation class: "B"
- Installation position: any
- Mode: continuous operation (S1)
- Mounting: maintenance-free ball bearings

Electrical data

- Motor protection: thermal overload protector (TOP) internally connected
- Electrical hookup: cable for connection on motor side
- Cable exit: lateral
- Protection class: II
- Speed levels: 2 (programmable) compatible with plug-in module CCC000-AE**.-**

EMC

- Immunity to interference: according to EN 61000-6-2 (industrial environment)
- Interference emission: according to EN 61000-6-3 (household environment)
- System disturbance: according to EN 61000-3-2/3

Standards and approvals

- Conformity with standards: EN 60335-1; EN 60335-2-24; EN 60335-2-80; EN 60335-2-89; CE
- Approvals: VDE; UL 1004-3; EAC; CSA C22.2 No. 77

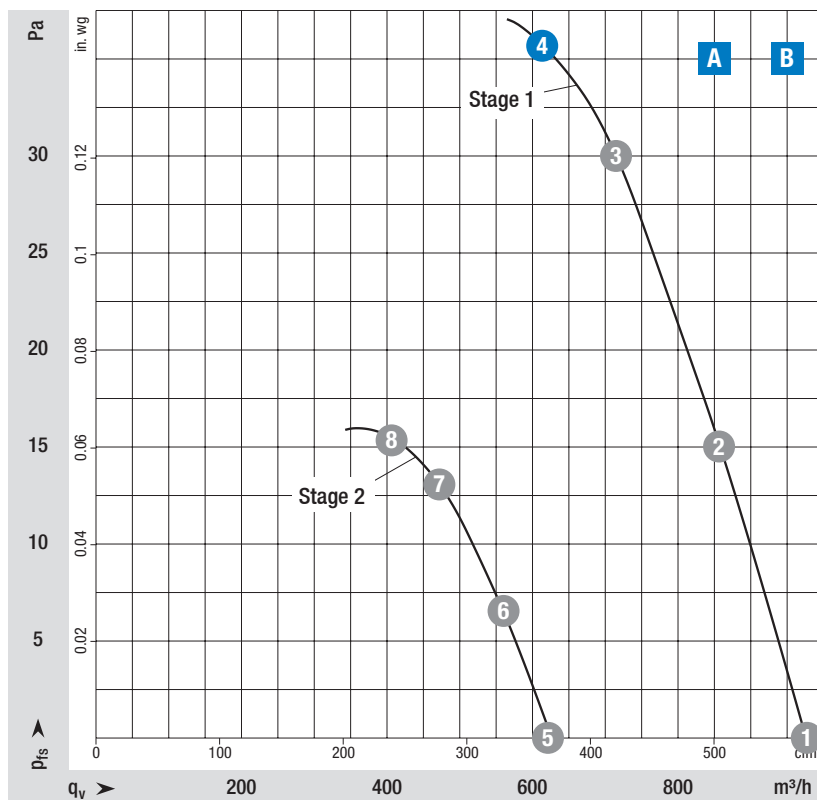

Measuring requirements

Air performance measured according to: ISO 5801, installation category A, in ebm-papst full nozzle without contact protection. Intake-side sound level: L_{pA} according to ISO 13347, L_{pA} measured at 1 m distance from fan axis. The values given are only applicable under the specified measuring conditions and may differ depending on the installation conditions. In the event of deviation from the standard configuration, the parameters must be checked in installed condition.

Curve	Operating point	Nominal voltage	Frequency	Speed n	Input power P _{ed}	Input current I	Sound power level L _w /A	Back pressure ⁽¹⁾	Perm. ambient temp.	Conn. diagram
		VAC	Hz	min ⁻¹	W	A	dB(A)	Pa	°C	
Nominal voltage 115 VAC										
A	① Stage 1	115	50/60	1500	23	0.35	58	0	-30...+50	ESM1)
	② Stage 1	115	50/60	1500	23	0.35	58	15		
	③ Stage 1	115	50/60	1500	23	0.35	58	30		
	④ Stage 1	115	50/60	1500	23	0.35	56	36		
	⑤ Stage 2	115	50/60	1000	9	0.15	48	0		
	⑥ Stage 2	115	50/60	1000	10	0.17	48	6		
	⑦ Stage 2	115	50/60	1000	10	0.17	48	13		
	⑧ Stage 2	115	50/60	1000	10	0.16	50	15		
Nominal voltage 230 VAC										
B	① Stage 1	230	50/60	1500	24	0.19	58	0	-30...+50	ESM1)
	② Stage 1	230	50/60	1500	25	0.18	58	15		
	③ Stage 1	230	50/60	1500	25	0.19	58	30		
	④ Stage 1	230	50/60	1500	26	0.20	56	36		
	⑤ Stage 2	230	50/60	1000	10	0.09	48	0		
	⑥ Stage 2	230	50/60	1000	11	0.09	48	7		
	⑦ Stage 2	230	50/60	1000	11	0.10	48	13		
	⑧ Stage 2	230	50/60	1000	11	0.09	50	16		

Values set in blue are nominal data at operating point with maximum load and 115 or 230 VAC.

Subject to change. ⁽¹⁾ Max. recommended back pressure before saddle area.

Curve	EC axial fans	
	Part number	Weight
A	W1G230EB9701	1.0 kg
B	W1G230EB8901	1.0 kg

Engineering drawing

Dimensions in mm

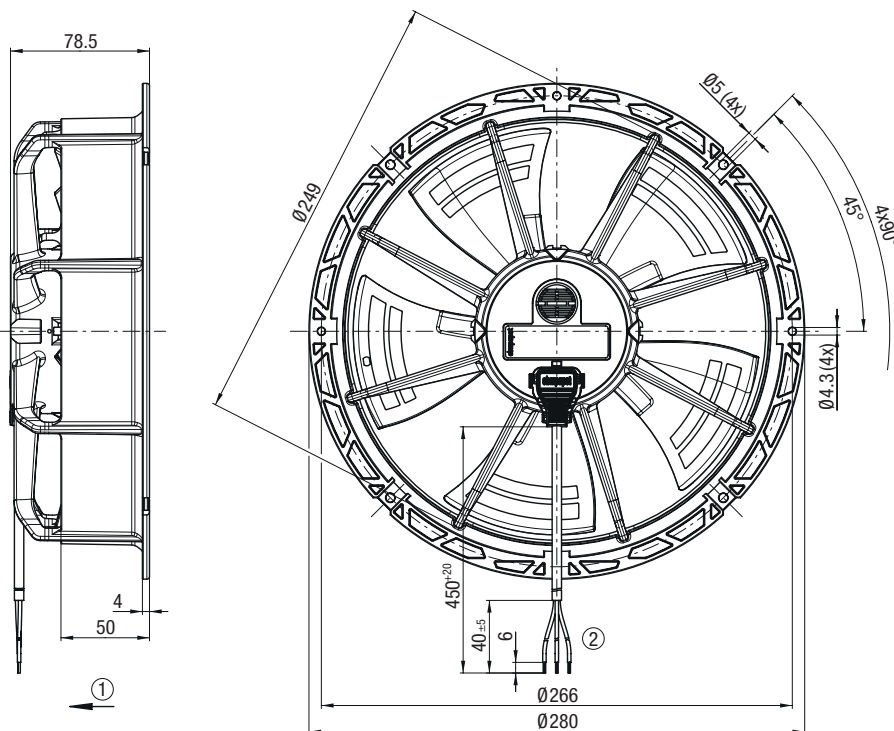

Fan also available with flat-type fan housing (type B). See page 105.

- ① Direction of airflow: "V"
- ② Cable PVC AWG20, 3x crimped splice

EC axial fans

Ø 250 mm, 2 speed levels (programmable)



on Page 90	Accessories
on Page 108	Connection diagrams and technical features
on Page 120	Technical parameters and scope
More at	www.ebmpapst.com

Material/surface

- Housing: plastic
- Impeller: plastic

Mechanical data

- Number of blades: 5
- Direction of airflow: blowing over struts ("V")
- Direction of rotation: counter-clockwise viewed toward rotor
- Degree of protection: IP 55
- Insulation class: "B"
- Installation position: any
- Mode: continuous operation (S1)
- Mounting: maintenance-free ball bearings

Electrical data

- Motor protection: thermal overload protector (TOP) internally connected
- Electrical hookup: cable for connection on motor side
- Cable exit: lateral
- Protection class: II
- Speed levels: 2 (programmable) compatible with plug-in module CCC000-AE**-**

EMC

- Immunity to interference: according to EN 61000-6-2 (industrial environment)
- Interference emission: according to EN 61000-6-3 (household environment)
- System disturbance: according to EN 61000-3-2/3

Standards and approvals

- Conformity with standards: EN 60335-1; EN 60335-2-24; EN 60335-2-80; EN 60335-2-89; CE
- Approvals: VDE; UL 1004-3; EAC; CSA C22.2 No. 77 + CAN/CSA-E60730-1

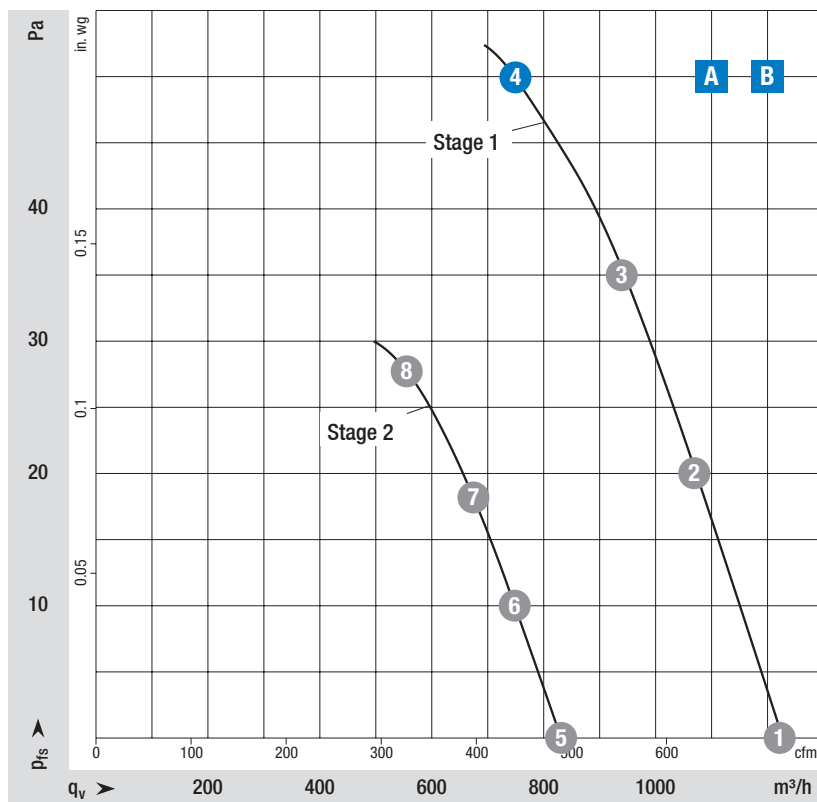

Measuring requirements

Air performance measured according to: ISO 5801, installation category A, in ebm-papst full nozzle without contact protection.
 Intake-side sound level: L_{pA} according to ISO 13347, L_p measured at 1 m distance from fan axis. The values given are only applicable under the specified measuring conditions and may differ depending on the installation conditions. In the event of deviation from the standard configuration, the parameters must be checked in installed condition.

Curve	Operating point	Nominal voltage	Frequency	Speed n	Input power P _{ed}	Input current I	Sound power level L _w /A	Back pressure ⁽¹⁾	Perm. ambient temp.	Conn. diagram
		VAC	Hz	min ⁻¹	W	A	dB(A)	Pa	°C	
Nominal voltage 115 VAC										
A	1 Stage 1	115	50/60	1720	29	0.42	63	0	-30...+50	ESM1)
	2 Stage 1	115	50/60	1665	31	0.45	62	20		
	3 Stage 1	115	50/60	1625	32	0.47	61	35		
	4 Stage 1	115	50/60	1590	33	0.50	62	50		
	5 Stage 2	115	50/60	1200	12	0.20	55	0		
	6 Stage 2	115	50/60	1190	14	0.22	53	10		
	7 Stage 2	115	50/60	1190	16	0.25	52	18		
	8 Stage 2	115	50/60	1195	17	0.27	52	28		
Nominal voltage 230 VAC										
B	1 Stage 1	230	50/60	1700	31	0.25	64	0	-30...+50	ESM1)
	2 Stage 1	230	50/60	1685	32	0.26	63	20		
	3 Stage 1	230	50/60	1650	33	0.27	62	35		
	4 Stage 1	230	50/60	1600	35	0.28	63	50		
	5 Stage 2	230	50/60	1200	13	0.12	55	0		
	6 Stage 2	230	50/60	1200	14	0.13	53	10		
	7 Stage 2	230	50/60	1200	15	0.14	52	18		
	8 Stage 2	230	50/60	1200	17	0.15	56	27		

Values set in blue are nominal data at operating point with maximum load and 115 or 230 VAC.

Subject to change. ⁽¹⁾ Max. recommended back pressure before saddle area.

Curve	EC axial fans	
	Part number	Weight
A	W1G250EB2101	1.0 kg
B	W1G250EB1701	1.0

Engineering drawing

Dimensions in mm

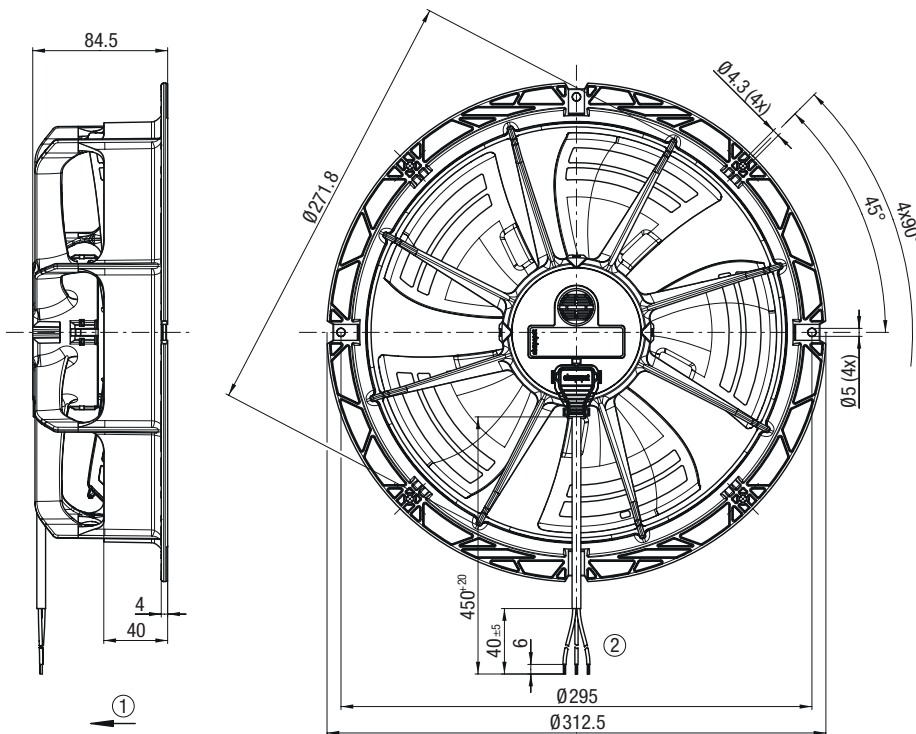

Fan also available with flat-type fan housing (type B). See page 105.

- ① Direction of airflow: "V"
- ② Cable PVC AWG20, 3x crimped splice

EC axial fans

Ø 250 mm, 2 speed levels (programmable)



on Page 90	Accessories
on Page 108	Connection diagrams and technical features
on Page 120	Technical parameters and scope
More at	www.ebmpapst.com

Material/surface

- Housing: plastic
- Impeller: plastic

Mechanical data

- Number of blades: 5
- Direction of airflow: blowing over struts ("V")
- Direction of rotation: counter-clockwise viewed toward rotor
- Degree of protection: IP 55
- Insulation class: "B"
- Installation position: any
- Mode: continuous operation (S1)
- Mounting: maintenance-free ball bearings

Electrical data

- Motor protection: thermal overload protector (TOP) internally connected
- Electrical hookup: cable for connection on motor side
- Cable exit: lateral
- Protection class: II
- Speed levels: 2 (programmable) compatible with plug-in module CCC000-AE**.-**

EMC

- Immunity to interference: according to EN 61000-6-2 (industrial environment)
- Interference emission: according to EN 61000-6-3 (household environment)
- System disturbance: according to EN 61000-3-2/3

Standards and approvals

- Conformity with standards: EN 60335-1; EN 60335-2-24; EN 60335-2-80; EN 60335-2-89; CE
- Approvals: VDE; UL 1004-3; EAC; CSA C22.2 No. 77

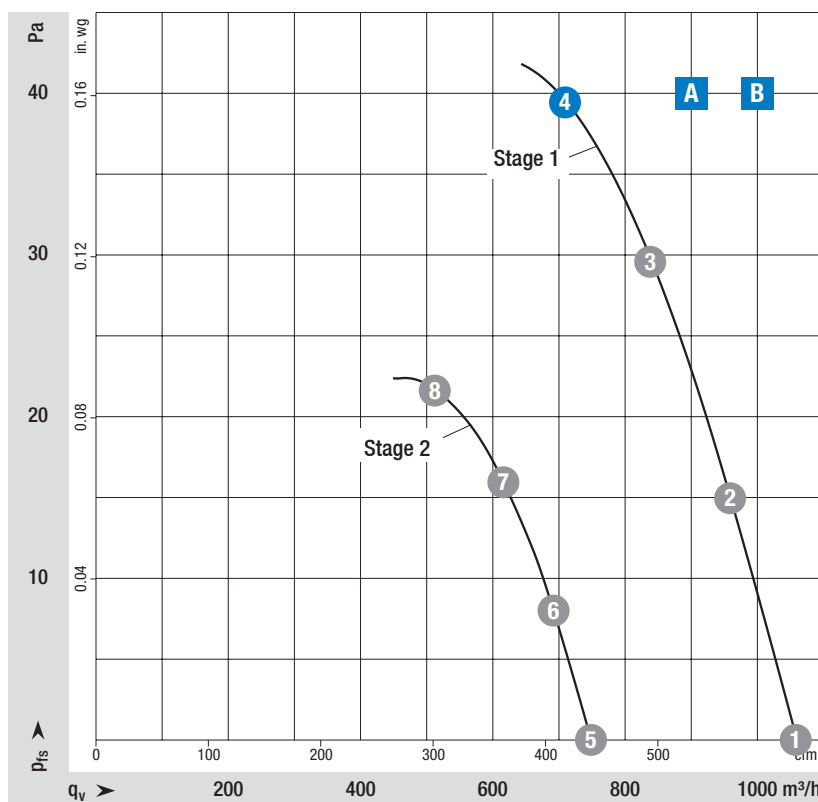

Measuring requirements

Air performance measured according to: ISO 5801, installation category A, in ebm-papst full nozzle without contact protection. Intake-side sound level: L_{wA} according to ISO 13347, L_{wA} measured at 1 m distance from fan axis. The values given are only applicable under the specified measuring conditions and may differ depending on the installation conditions. In the event of deviation from the standard configuration, the parameters must be checked in installed condition.

Curve	Operating point	Nominal voltage	Frequency	Speed n	Input power P _{ed}	Input current I	Sound power level L _w /A	Back pressure ⁽¹⁾	Perm. ambient temp.	Conn. diagram
		VAC	Hz	min ⁻¹	W	A	dB(A)	Pa	°C	
Nominal voltage 115 VAC										
A	① Stage 1	115	50/60	1700	30	0.44	62	0	-30...+50	ESM1)
	② Stage 1	115	50/60	1700	31	0.45	63	15		
	③ Stage 1	115	50/60	1700	32	0.47	64	30		
	④ Stage 1	115	50/60	1700	32	0.47	66	40		
	⑤ Stage 2	115	50/60	1200	14	0.22	53	0		
	⑥ Stage 2	115	50/60	1200	15	0.24	54	8		
	⑦ Stage 2	115	50/60	1200	16	0.25	55	16		
	⑧ Stage 2	115	50/60	1200	17	0.26	57	22		
Nominal voltage 230 VAC										
B	① Stage 1	230	50/60	1700	31	0.24	62	0	-30...+50	ESM1)
	② Stage 1	230	50/60	1700	32	0.24	63	15		
	③ Stage 1	230	50/60	1700	32	0.24	64	30		
	④ Stage 1	230	50/60	1700	32	0.24	66	40		
	⑤ Stage 2	230	50/60	1200	14	0.12	53	0		
	⑥ Stage 2	230	50/60	1200	15	0.13	54	8		
	⑦ Stage 2	230	50/60	1200	16	0.14	55	16		
	⑧ Stage 2	230	50/60	1200	17	0.14	57	22		

Values set in blue are nominal data at operating point with maximum load and 115 or 230 VAC.

Subject to change. ⁽¹⁾Max. recommended back pressure before saddle area.

Curve	EC axial fans	
	Part number	Weight
A	W1G250BB2101	1.5 kg
B	W1G250BB1701	1.5

Engineering drawing

Dimensions in mm

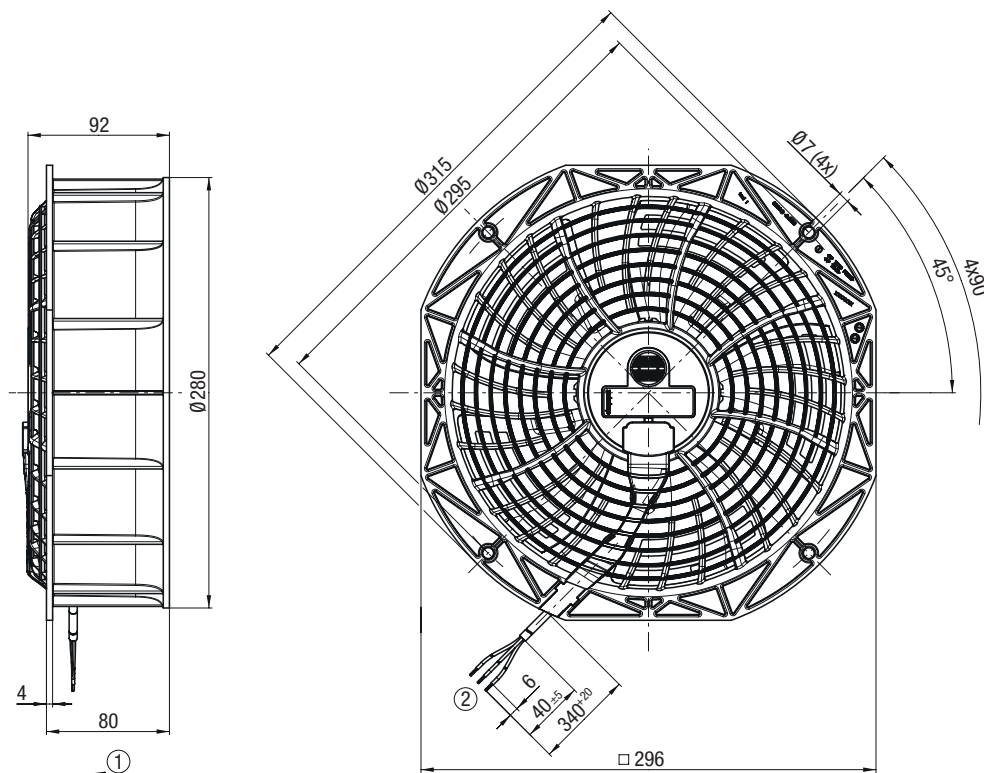

EC axial fans

Ø 300 mm, 2 speed levels (programmable)



on Page 90	Accessories
on Page 108	Connection diagrams and technical features
on Page 120	Technical parameters and scope
More at	www.ebmpapst.com

Material/surface

- Housing: plastic
- Impeller: plastic

Mechanical data

- Number of blades: 5
- Direction of airflow: blowing over struts ("V")
- Direction of rotation: counter-clockwise viewed toward rotor
- Degree of protection: IP 55
- Insulation class: "B"
- Installation position: any
- Mode: continuous operation (S1)
- Mounting: maintenance-free ball bearings

Electrical data

- Motor protection: thermal overload protector (TOP) internally connected
- Electrical hookup: cable for connection on motor side
- Cable exit: lateral
- Protection class: II
- Speed levels: 2 (programmable) compatible with plug-in module CCC000-AE**.*

EMC

- Immunity to interference: according to EN 61000-6-2 (industrial environment)
- Interference emission: according to EN 61000-6-3 (household environment)
- System disturbance: according to EN 61000-3-2/3

Standards and approvals

- Conformity with standards: EN 60335-1; EN 60335-2-24; EN 60335-2-80; EN 60335-2-89; CE
- Approvals:
 - A** VDE; UL 1004-3; EAC; CSA C22.2 No. 77
 - B** VDE; UL 1004-3; EAC; CSA C22.2 No. 77; CCC

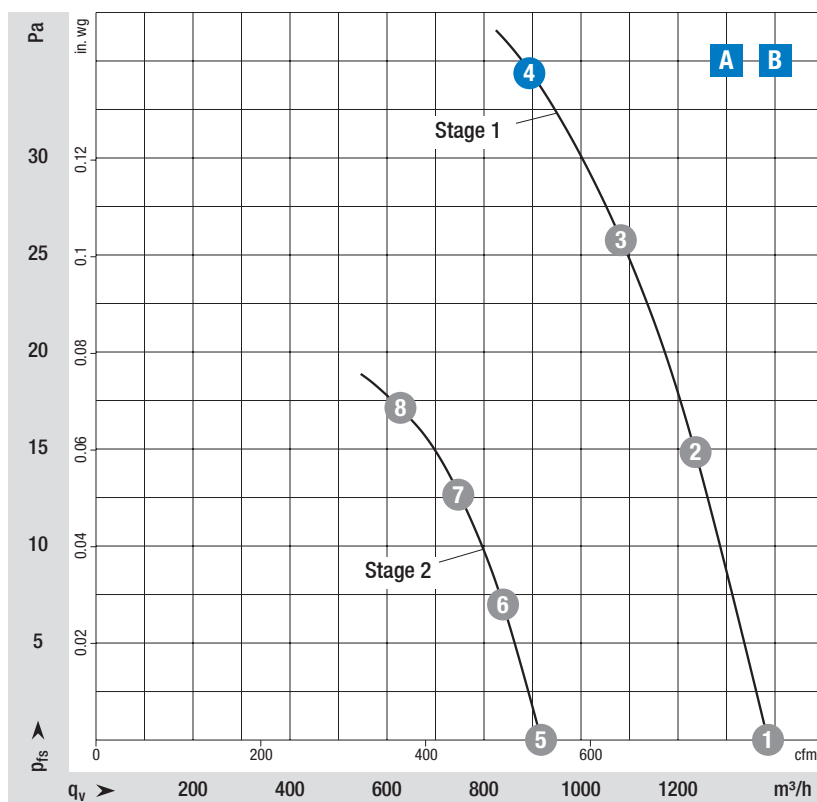

Measuring requirements
 Air performance measured according to: ISO 5801, installation category A, in ebm-papst full nozzle without contact protection.
 Intake-side sound level: L_{pA} according to ISO 13347, L_{pA} measured at 1 m distance from fan axis. The values given are only applicable under the specified measuring conditions and may differ depending on the installation conditions. In the event of deviation from the standard configuration, the parameters must be checked in installed condition.

Curve	Operating point	Nominal voltage	Frequency	Speed n	Input power P _{ed}	Input current I	Sound power level L _w /A	Back pressure ⁽¹⁾	Perm. ambient temp.	Conn. diagram
		VAC	Hz	min ⁻¹	W	A	dB(A)	Pa	°C	
Nominal voltage 115 VAC										
A	1 Stage 1	115	50/60	1300	28	0.41	58	0	-30...+50	ESM1)
	2 Stage 1	115	50/60	1300	31	0.46	58	15		
	3 Stage 1	115	50/60	1300	32	0.47	57	25		
	4 Stage 1	115	50/60	1300	35	0.50	58	35		
	5 Stage 2	115	50/60	900	12	0.24	50	0		
	6 Stage 2	115	50/60	900	14	0.25	49	7		
	7 Stage 2	115	50/60	900	15	0.26	49	13		
	8 Stage 2	115	50/60	900	16	0.27	50	18		
Nominal voltage 230 VAC										
B	1 Stage 1	230	50/60	1300	32	0.25	58	0	-30...+50	ESM1)
	2 Stage 1	230	50/60	1300	34	0.27	58	15		
	3 Stage 1	230	50/60	1300	34	0.27	57	28		
	4 Stage 1	230	50/60	1300	35	0.27	58	35		
	5 Stage 2	230	50/60	900	13	0.12	50	0		
	6 Stage 2	230	50/60	900	14	0.13	49	7		
	7 Stage 2	230	50/60	900	15	0.14	49	13		
	8 Stage 2	230	50/60	900	16	0.15	50	17		

Values set in blue are nominal data at operating point with maximum load and 115 or 230 VAC.

Subject to change. ⁽¹⁾Max. recommended back pressure before saddle area.

Curve	EC axial fans	
	Part number	Weight
A	W1G300BB2301	1.75 kg
B	W1G300BB1901	1.75

Engineering drawing

Dimensions in mm

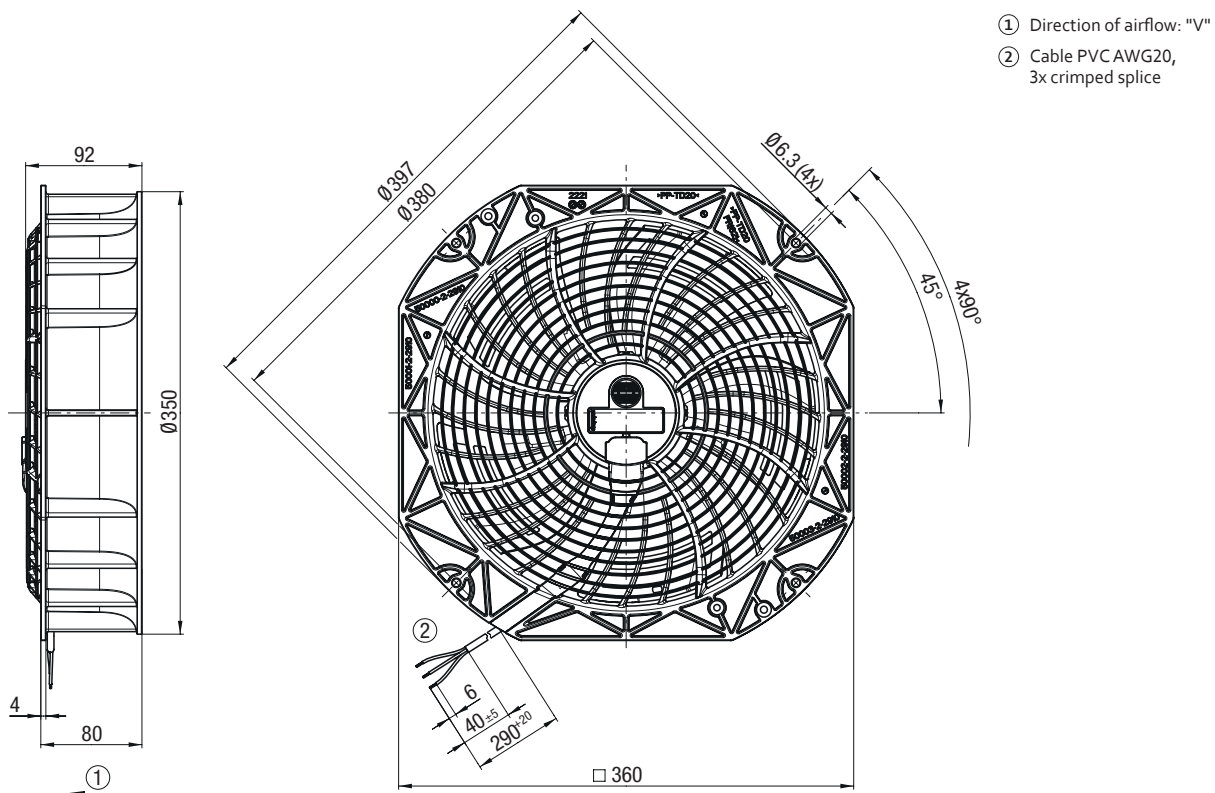



Diagonal fans

ebmpapst

the engineer's choice

	Page
Ø 200 mm	62
Ø 250 mm	66

EC diagonal fan

Ø 200 mm, 2 speed levels (not programmable), 100-240 V



Material/surface

- Support bracket: plastic
- Impeller: plastic

Mechanical data

- Number of blades: 7
- Direction of rotation: clockwise viewed toward rotor
- Degree of protection: IP 55
- Insulation class: "B"
- Installation position: any
- Mode: continuous operation (S1)
- Mounting: maintenance-free ball bearings

Electrical data

- Motor protection: electronic
- Electrical hookup: cable for connection on motor side
- Protection class: II
- Speed levels: 2 (not programmable)

Standards and approvals

- Conformity with standards: EN 60335-1; EN 60335-2-42; EN 60335-2-80; CE
- Approvals: UL 1004-7; VDE; CSA C22.2 No. 77

on Page 90	Accessories
on Page 108	Connection diagrams and technical features
on Page 120	Technical parameters and scope
More at	www.ebmpapst.com

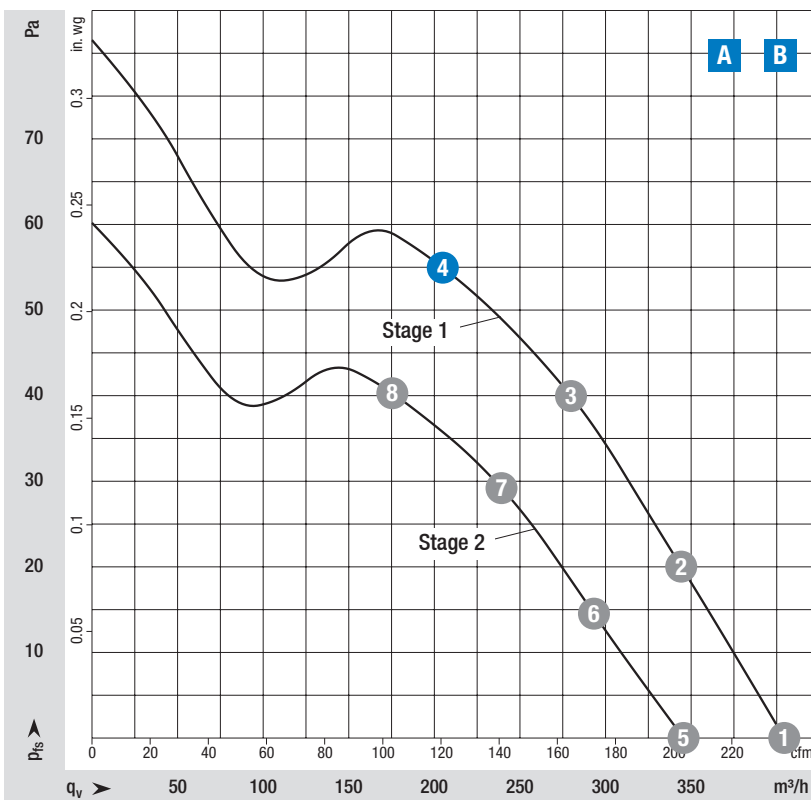

Measuring requirements

Air performance measured according to: ISO 5801, installation category A, in ebm-papst full nozzle without contact protection.
 Intake-side sound level: L_{pA} according to ISO 13347, L_{pA} measured at 1 m distance from fan axis. The values given are only applicable under the specified measuring conditions and may differ depending on the installation conditions. In the event of deviation from the standard configuration, the parameters must be checked in installed condition.

Curve	Operating point	Nominal voltage	Frequency	Speed n	Input power P _{ed}	Input current I	Sound power level L _w /A	Back pressure ⁽¹⁾	Perm. ambient temp.	Conn. diagram
		VAC	Hz	min ⁻¹	W	A	dB(A)	Pa	°C	
Voltage range 100-240 VAC										
A	1 Stage 1	115	50	1400	9	0.14	57	0	-30...+50	ESM1)
	2 Stage 1	115	50	1400	10	0.15	55	20		
	3 Stage 1	115	50	1400	11	0.16	54	40		
	4 Stage 1	115	50	1400	11	0.16	54	55		
	5 Stage 2	115	50	1200	6	0.10	53	0		
	6 Stage 2	115	50	1200	7	0.11	51	15		
	7 Stage 2	115	50	1200	7	0.11	50	29		
	8 Stage 2	115	50	1200	7	0.11	50	40		

Values set in blue are nominal data at operating point with maximum load and 115 VAC.

Subject to change. ⁽¹⁾Max. recommended back pressure before saddle area.

Curve	EC diagonal fan	
	Part number	Weight
A	K1G200AA8220	1.1 kg

Engineering drawing

Dimensions in mm

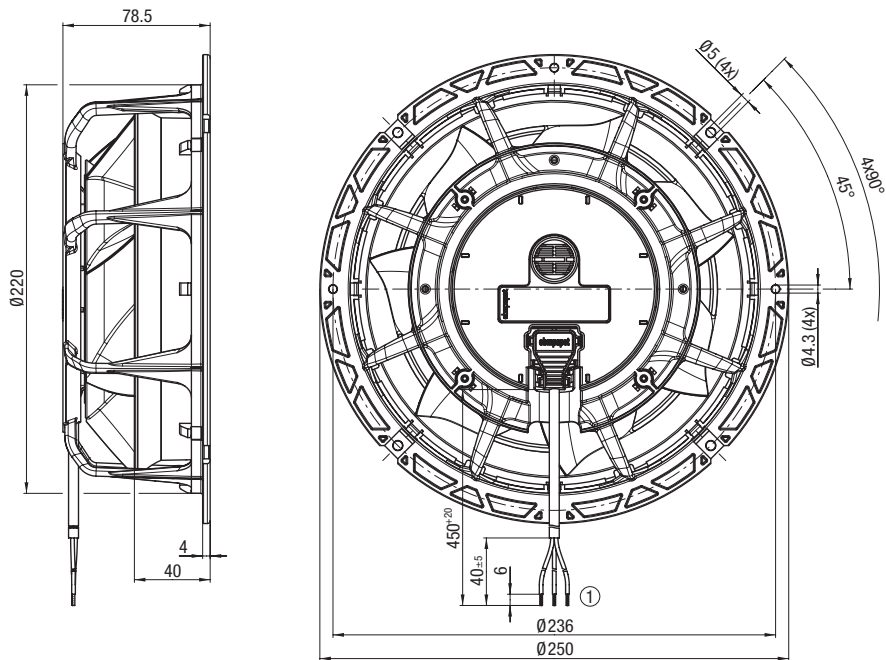

① Cable PVC AWG20, 3x splice

EC diagonal fans

Ø 200 mm, 2 speed levels (programmable)



on Page 90	Accessories
on Page 108	Connection diagrams and technical features
on Page 120	Technical parameters and scope
More at	www.ebmpapst.com

Material/surface

- Support bracket: plastic
- Impeller: plastic

Mechanical data

- Number of blades: 7
- Direction of rotation: clockwise viewed toward rotor
- Degree of protection: IP 55
- Insulation class: "B"
- Installation position: any
- Mode: continuous operation (S1)
- Mounting: maintenance-free ball bearings

Electrical data

- Motor protection: thermal overload protector (TOP) internally connected
- Electrical hookup: cable for connection on motor side
- Protection class: II
- Speed levels: 2 (programmable) compatible with plug-in module CCC000-AE**-**

EMC

- Immunity to interference: according to EN 61000-6-2 (industrial environment)
- Interference emission: according to EN 61000-6-3 (household environment)
- System disturbance: according to EN 61000-3-2/3

Standards and approvals

- Conformity with standards: EN 60335-1; EN 60335-2-24; EN 60335-2-80; EN 60335-2-89; CE
- Approvals:
 - A** UL 1004-3; VDE; EAC; CSA C22.2 No. 77
 - B** UL 1004-3; VDE; CCC; EAC; CSA C22.2 No. 77

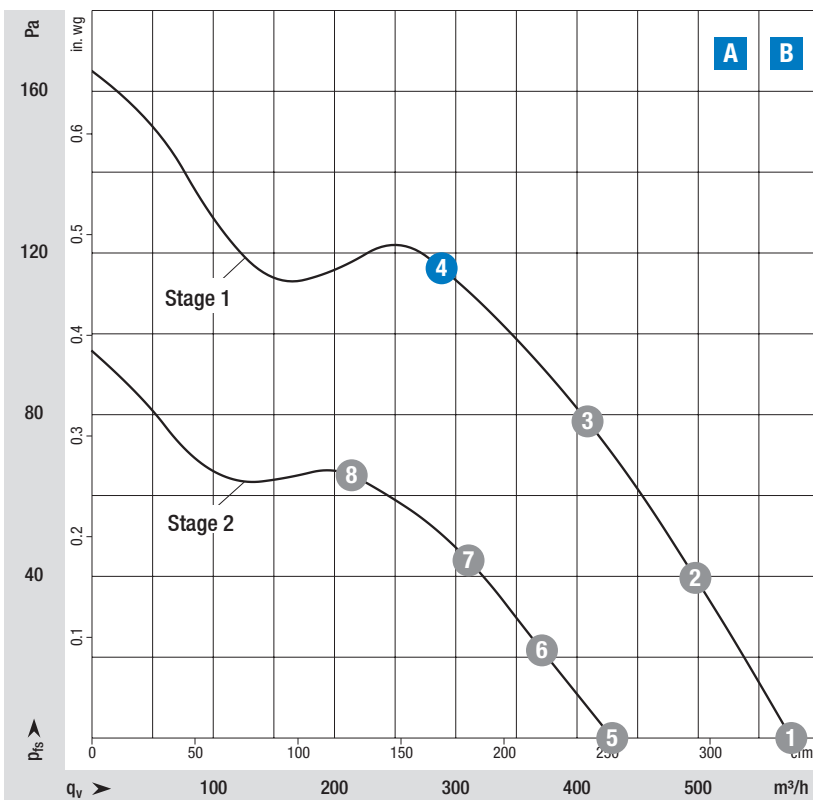

Measuring requirements

Air performance measured according to: ISO 5801, installation category A, in ebm-papst full nozzle without contact protection.
 Intake-side sound level: L_{pA} according to ISO 13347, L_{pA} measured at 1 m distance from fan axis. The values given are only applicable under the specified measuring conditions and may differ depending on the installation conditions. In the event of deviation from the standard configuration, the parameters must be checked in installed condition.

Curve	Operating point	Nominal voltage	Frequency	Speed n	Input power P _{ed}	Input current I	Sound power level L _w /A	Back pressure ⁽¹⁾	Perm. ambient temp.	Conn. diagram
		VAC	Hz	min ⁻¹	W	A	dB(A)	Pa	°C	
Nominal voltage 115 VAC										
A	1 Stage 1	115	50/60	2000	27	0.38	69	0	-30...+50	ESM1)
	2 Stage 1	115	50/60	2000	29	0.42	62	40		
	3 Stage 1	115	50/60	2000	31	0.50	62	80		
	4 Stage 1	115	50/60	2000	30	0.43	64	120		
	5 Stage 2	115	50/60	1500	14	0.22	56	0		
	6 Stage 2	115	50/60	1500	16	0.24	55	22		
	7 Stage 2	115	50/60	1500	17	0.26	54	46		
	8 Stage 2	115	50/60	1500	16	0.25	57	67		
Nominal voltage 230 VAC										
B	1 Stage 1	230	50/60	2000	31	0.24	63	0	-30...+50	ESM1)
	2 Stage 1	230	50/60	2000	33	0.26	62	40		
	3 Stage 1	230	50/60	2000	35	0.30	62	80		
	4 Stage 1	230	50/60	2000	35	0.27	64	120		
	5 Stage 2	230	50/60	1500	16	0.13	56	0		
	6 Stage 2	230	50/60	1500	19	0.14	55	22		
	7 Stage 2	230	50/60	1500	20	0.18	54	45		
	8 Stage 2	230	50/60	1500	18	0.14	57	68		

Values set in blue are nominal data at operating point with maximum load and 115 or 230 VAC.

Subject to change. ⁽¹⁾ Max. recommended back pressure before saddle area.

Curve	EC diagonal fans	
	Part number	Weight
		kg
A	K1G200AA9502	1.2
B	K1G200AA7302	1.2

Engineering drawing

Dimensions in mm

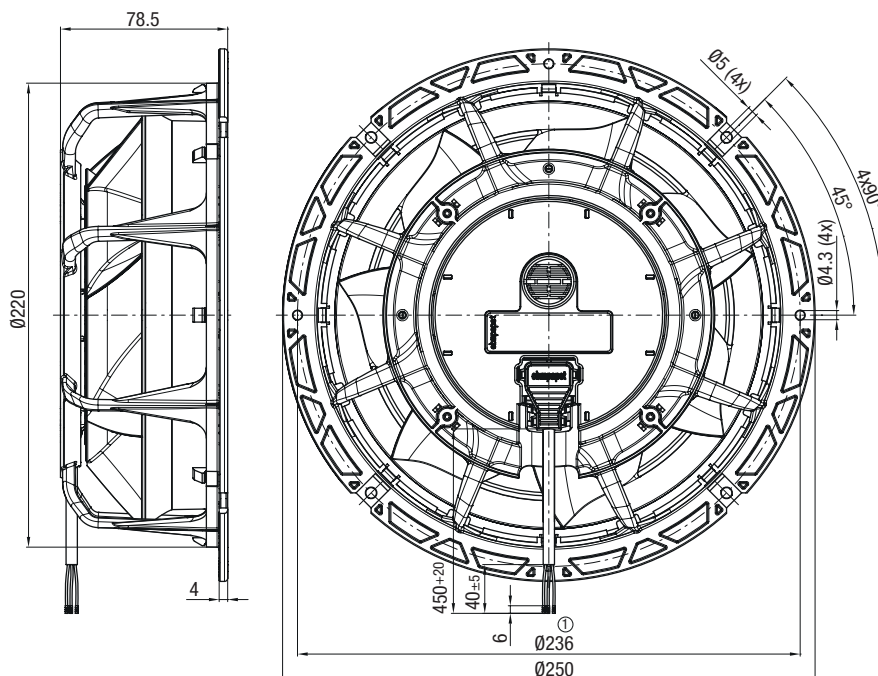

① Cable PVC AWG20, 3x crimped splice

EC diagonal fans

Ø 250 mm, 2 speed levels (programmable)



Material/surface

- Support bracket: plastic
- Impeller: plastic
- Rotor: thick-film passivated

Mechanical data

- Number of blades: 5
- Direction of rotation: clockwise viewed toward rotor
- Degree of protection: IP 55
- Insulation class: "B"
- Installation position: any
- Mode: continuous operation (S1)
- Mounting: maintenance-free ball bearings

Electrical data

- Motor protection: thermal overload protector (TOP) internally connected
- Electrical hookup: cable for connection on motor side
- Protection class: II
- Speed levels: 2 (programmable) compatible with plug-in module CCC000-AE**-**

Standards and approvals

- Conformity with standards: EN 60335-1; EN 60335-2-24; EN 60335-2-80; EN 60335-2-89; CE
- Approvals: UL 1004-3; VDE; EAC; CSA C22.2 No. 77

on Page 90	Accessories
on Page 108	Connection diagrams and technical features
on Page 120	Technical parameters and scope
More at	www.ebmpapst.com

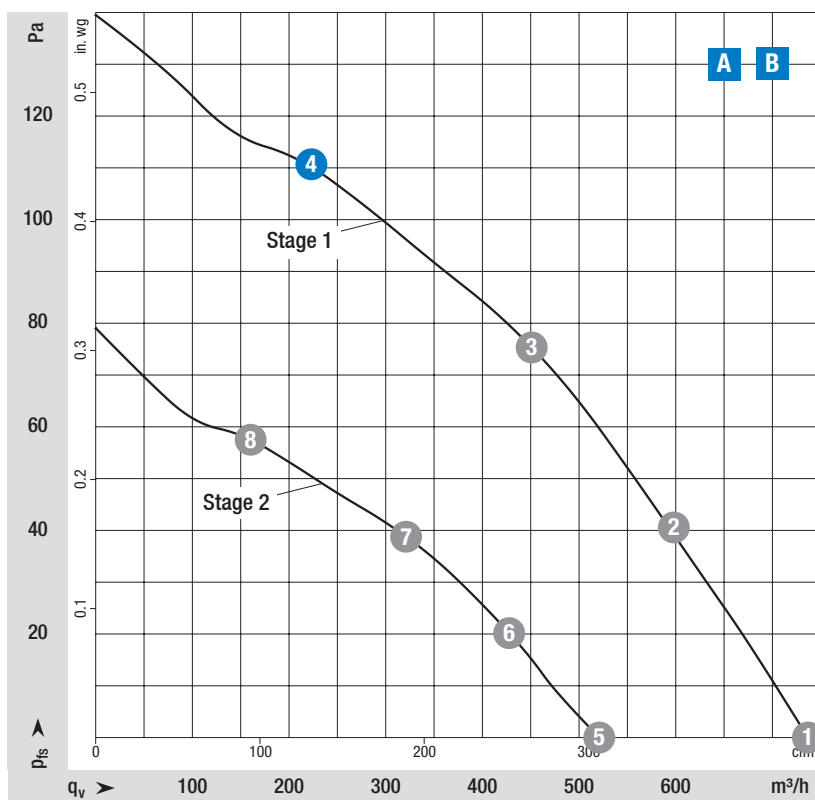

Measuring requirements

Air performance measured according to: ISO 5801, installation category A, in ebm-papst full nozzle without contact protection.
 Intake-side sound level: L_{pA} according to ISO 13347, L_{pA} measured at 1 m distance from fan axis. The values given are only applicable under the specified measuring conditions and may differ depending on the installation conditions. In the event of deviation from the standard configuration, the parameters must be checked in installed condition.

Curve	Operating point	Nominal voltage	Frequency	Speed n	Input power P _{ed}	Input current I	Sound power level L _w /A	Back pressure ⁽¹⁾	Perm. ambient temp.	Conn. diagram
		VAC	Hz	min ⁻¹	W	A	dB(A)	Pa	°C	
Nominal voltage 115 VAC										
A	1 Stage 1	115	50/60	1700	19	0.29	60	0	-30...+50	ESM1)
	2 Stage 1	115	50/60	1700	23	0.35	58	40		
	3 Stage 1	115	50/60	1700	28	0.41	58	75		
	4 Stage 1	115	50/60	1700	30	0.43	62	110		
	5 Stage 2	115	50/60	1200	9	0.14	52	0		
	6 Stage 2	115	50/60	1200	10	0.17	49	19		
	7 Stage 2	115	50/60	1200	12	0.19	50	38		
	8 Stage 2	115	50/60	1200	13	0.21	53	57		
Nominal voltage 230 VAC										
B	1 Stage 1	230	50/60	1700	18	0.16	60	0	-30...+50	ESM1)
	2 Stage 1	230	50/60	1700	23	0.19	58	40		
	3 Stage 1	230	50/60	1700	28	0.23	58	75		
	4 Stage 1	230	50/60	1700	30	0.24	61	110		
	5 Stage 2	230	50/60	1200	9	0.07	52	0		
	6 Stage 2	230	50/60	1200	10	0.08	49	20		
	7 Stage 2	230	50/60	1200	12	0.09	50	39		
	8 Stage 2	230	50/60	1200	13	0.10	53	58		

Values set in blue are nominal data at operating point with maximum load and 115 or 230 VAC.

Subject to change. ⁽¹⁾Max. recommended back pressure before saddle area.

Curve	EC diagonal fans	
	Part number	Weight
A	K1G250AA2102	1.2 kg
B	K1G250AA1702	1.2 kg

Engineering drawing

Dimensions in mm

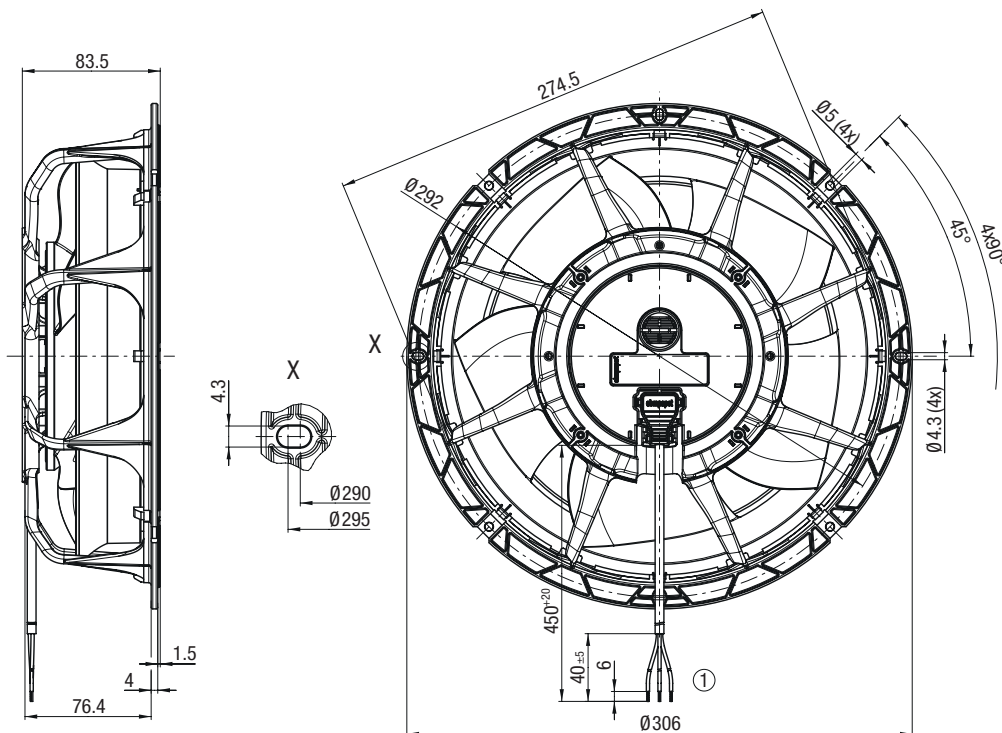

① Cable PVC AWG20, 3x splice



Tangential fans

ebmpapst

the engineer's choice

	Page
Series QLZ 06	70
Series QLN 65	74
Series QL 80	76

EC tangential fans

Series QLZ 06



Material/surface

- Fan housing: sheet steel hot-dip galvanized
- Motor housing: aluminium
- Roller: aluminium

Mechanical data

- Motor degree of protection: IP 54
- Insulation class: I.Cl.H
- Installation position: any
- Mode: continuous operation (S1)
- Mounting: maintenance-free ball bearings

Electrical data

- Electrical hookup:

A receptacles

B splices

C receptacles

- Cable exit: 3 x 0.5 mm²
- Protection class: I

Standards and approvals

- Approvals: CE, EAC

on Page 90	Accessories
on Page 108	Connection diagrams and technical features
on Page 120	Technical parameters and scope
More at	www.ebmpapst.com

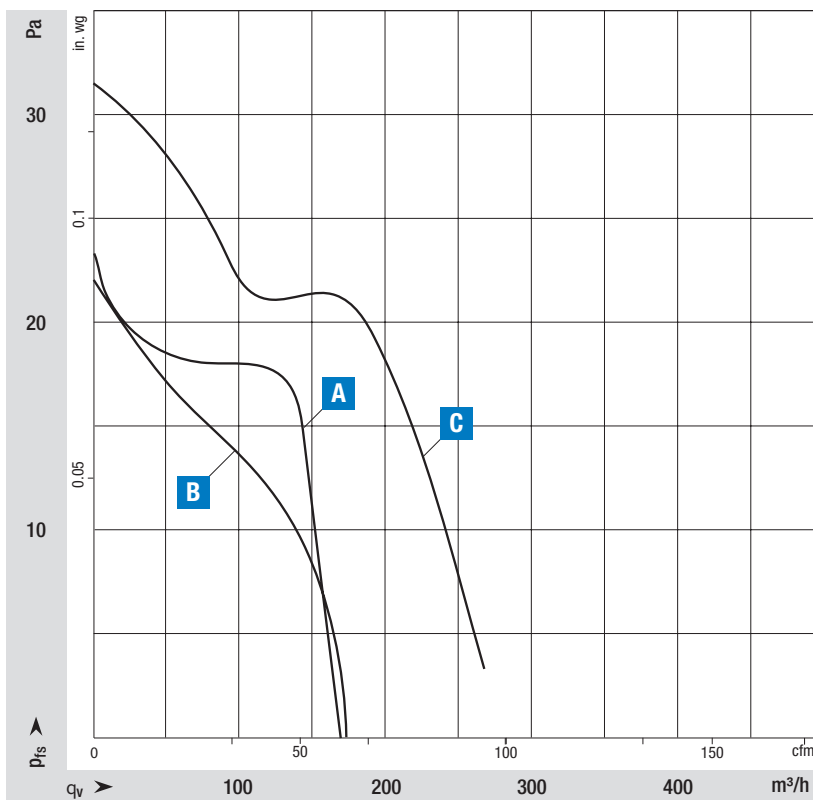

Measuring requirements

Air performance measured according to: ISO 5801, installation category A.

The values given are only applicable under the specified measuring conditions and may differ depending on the installation conditions.

In the event of deviation from the standard configuration, the parameters must be checked in installed condition.

Curve	Nominal voltage	Frequency	Speed n	Max. input power P _{ed}	Max. input current I	Perm. ambient temp.	Conn. diagram
	VAC						
Voltage range 220-240 VAC							
A	230	50/60	1800	8.0	72		
B	230	50/60	1550	6.5	65	-40...+50	iQ1)
C	230	50/60	1800	12.0	110		

Subject to change.

Curve	EC tangential fans		
	Type	Part number	Weight kg
A	VTS0060XSHBS	5566872001	0.8
B	VTS0060XSHCZ	5566873010	1.1
C	VTS0060XSHCS	5566874000	1.2

Specifications apply to products with motor on right. Products with motor on left available on request.

Engineering drawing

Dimensions in mm

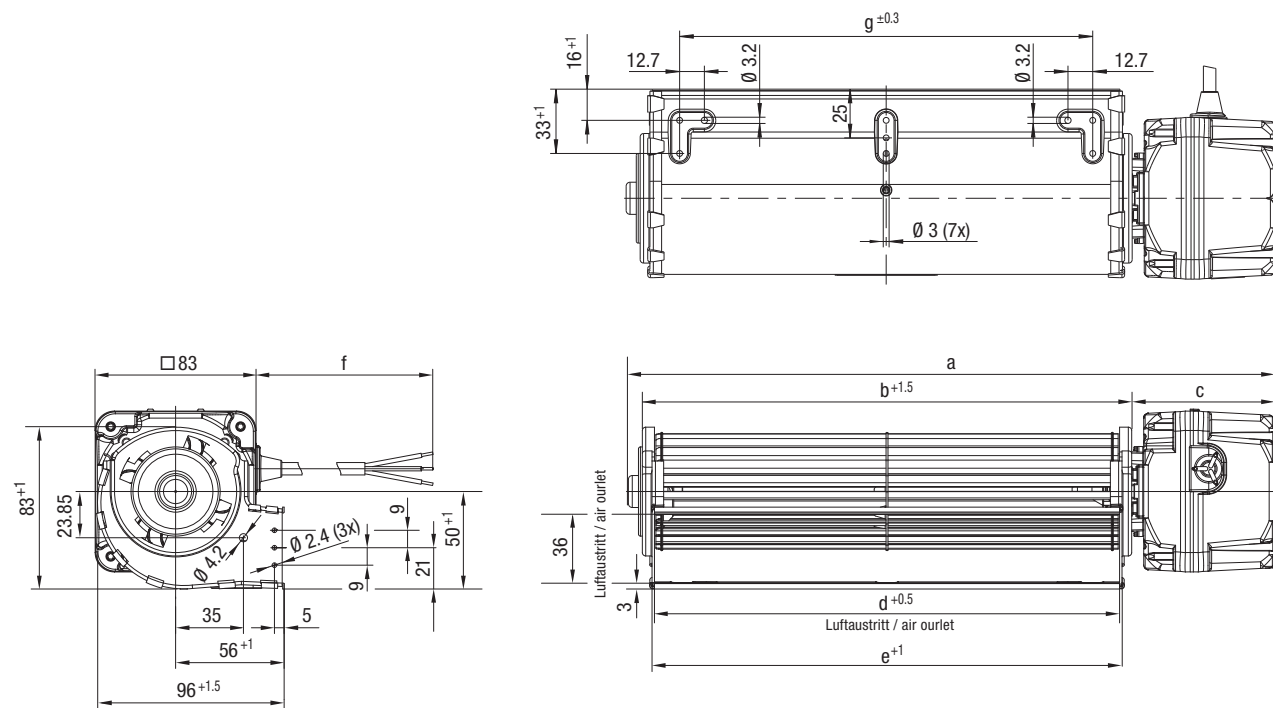

	Dimensions						
	a	b	c	d	e	f	g
A	max. 272.0	195.0	max. 67.0	182.5	185.0	480	154
B	max. 337.5	252.5	max. 74.5	240.0	242.5	2000	212
C	max. 397.5	312.5	max. 74.5	300.0	302.5	480	272

EC tangential fan

Series QLZ 06



Material/surface

- Fan housing: sheet steel hot-dip galvanized
- Motor housing: aluminium
- Roller: aluminium

Mechanical data

- Motor degree of protection: IP 54
- Insulation class: I.Cl.H
- Installation position: any
- Mode: continuous operation (S1)
- Mounting: maintenance-free ball bearings

Electrical data

- Electrical hookup: receptacles
- Cable exit: 3 x 0.5 mm²
- Protection class: I

Standards and approvals

- Approvals: CE, EAC

on Page 90	Accessories
on Page 108	Connection diagrams and technical features
on Page 120	Technical parameters and scope
More at	www.ebmpapst.com

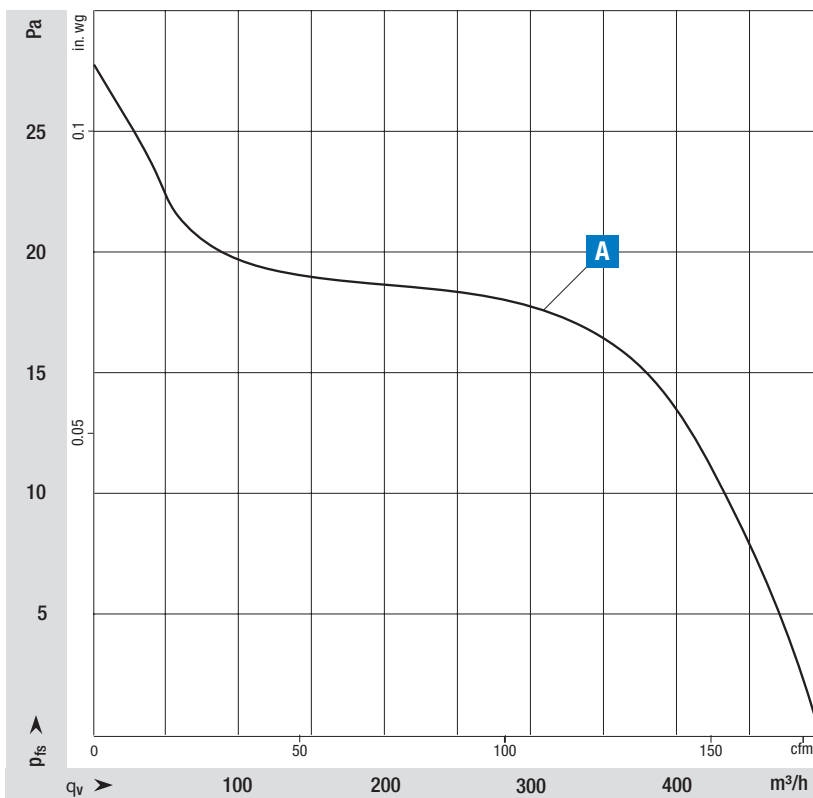

Measuring requirements

Air performance measured according to: ISO 5801, installation category A.

The values given are only applicable under the specified measuring conditions and may differ depending on the installation conditions.

In the event of deviation from the standard configuration, the parameters must be checked in installed condition.

Curve	Nominal voltage	Frequency	Speed n	Max. input power P _{ed}	Max. input current I	Perm. ambient temp.	Conn. diagram
	VAC	Hz	min ⁻¹	W	mA	°C	
Voltage range 220-240 VAC							
A	230	50/60	1700	22	190	-40...+50	iQ1)

Subject to change.

Curve	EC tangential fan		
	Type	Part number	Weight kg
A	VTD0060XSHCZ	5566876000	2.05

Specifications apply to products with motor on right. Products with motor on left available on request.

Engineering drawing

Dimensions in mm

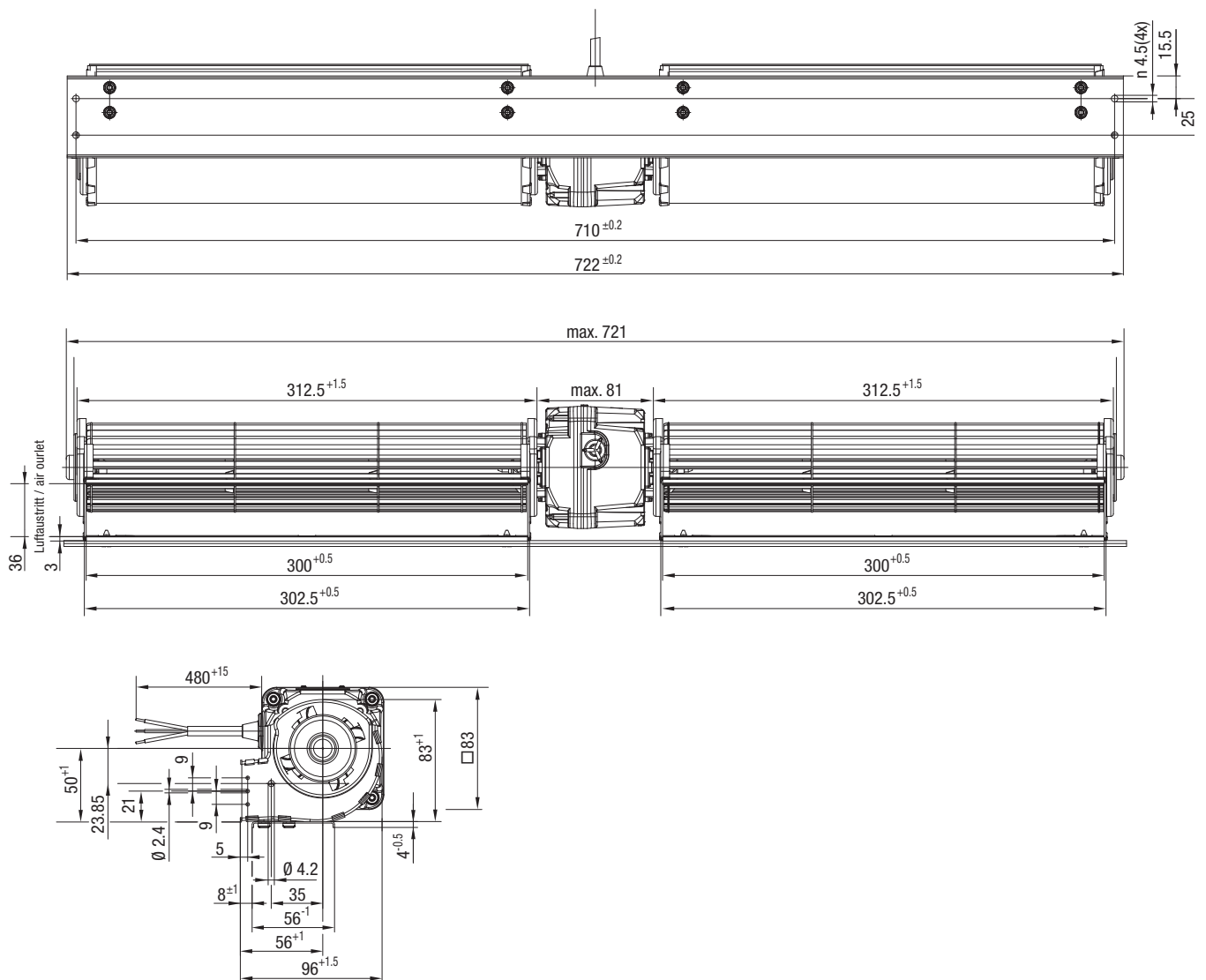

Tangential fans

EC tangential fans

Series QLN 65



Material/surface

- Fan housing: sheet steel hot-dip galvanized
- Motor housing: aluminium
- Roller: aluminium

Mechanical data

- Motor degree of protection: IP 54
- Insulation class: I.Cl.H
- Installation position: any
- Mode: continuous operation (S1)
- Mounting: maintenance-free ball bearings

Electrical data

- Electrical hookup: wires
- Cable exit: 3 x 0.5 mm²
- Protection class: I

Standards and approvals

- Approvals: CE, EAC

on Page 90	Accessories
on Page 108	Connection diagrams and technical features
on Page 120	Technical parameters and scope
More at	www.ebmpapst.com

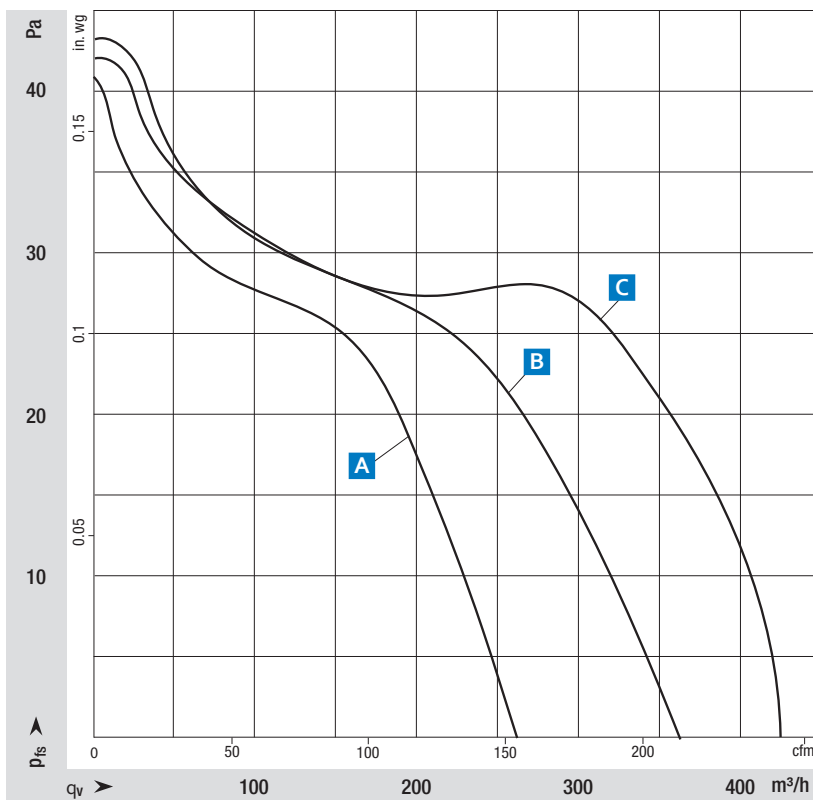

Measuring requirements

Air performance measured according to: ISO 5801, installation category A.

The values given are only applicable under the specified measuring conditions and may differ depending on the installation conditions.

In the event of deviation from the standard configuration, the parameters must be checked in installed condition.

Curve	Nominal voltage VAC	Frequency Hz	Speed n min ⁻¹	Max. input power P _{ed} W	Max. input current I mA	Perm. ambient temp. °C	Conn. diagram
Voltage range 220-240 VAC							
A	230	50/60	1800	14	125		
B	230	50/60	1800	19	170	-40...+50	iQ1)
C	230	50/60	1800	23	190		

Subject to change.

Curve	EC tangential fans		
	Type	Part number	Weight kg
A	VTS0065XSHCS	5566883000	1.15
B	VTS0065XSHCS	5566884010	1.20
C	VTS0065XSHCS	5566885000	1.30

Specifications apply to products with motor on right. Products with motor on left available on request.

Engineering drawing

Dimensions in mm

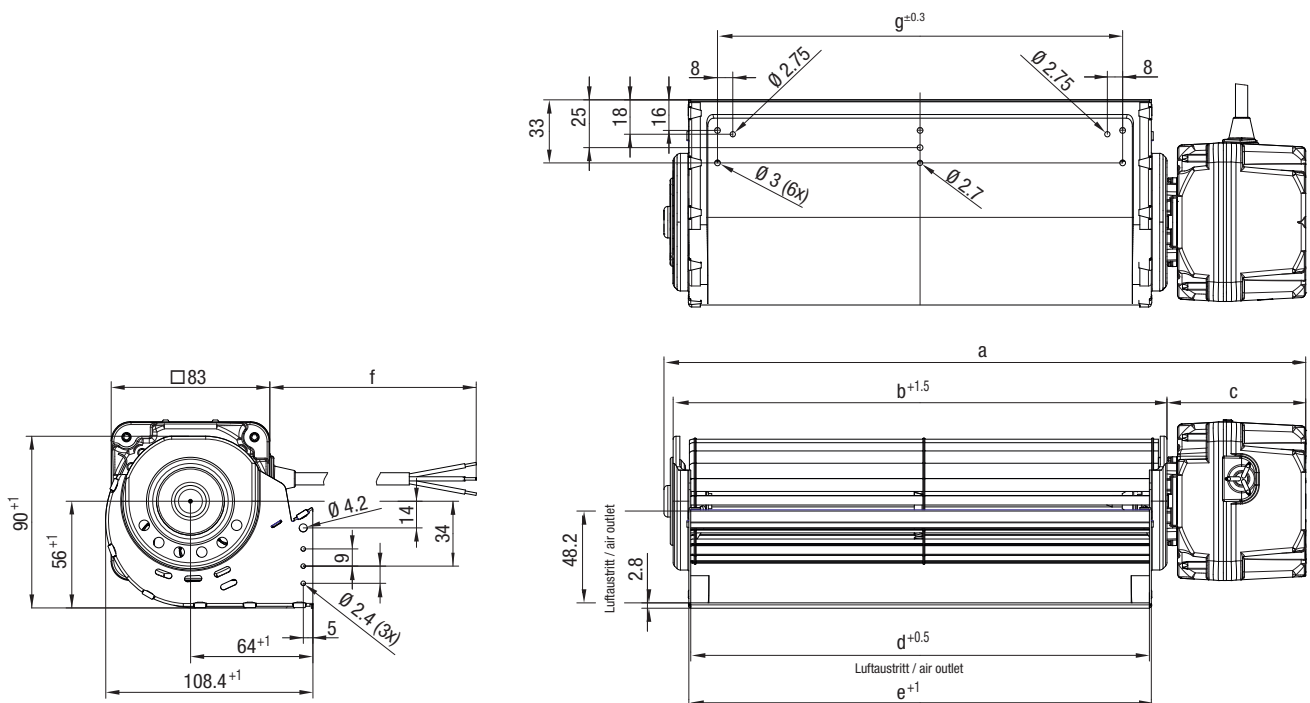

	Dimensions						
	a	b	c	d	e	f	g
A	max. 344	258.4	max. 74.5	240	242.5	1000	212
B	max. 404	318.4	max. 74.5	300	302.5	480	272
C	max. 464	378.4	max. 74.5	360	362.5	1000	332

DC tangential fans

Series QL 80



Material/surface

- Fan housing: aluminium, side panels hot-dip galvanized sheet steel
- Motor housing: aluminium
- Roller: aluminium

Mechanical data

- Motor degree of protection: IP 54
- Insulation class: I.Cl.H
- Installation position: any
- Mode: continuous operation (S1)
- Mounting: maintenance-free ball bearings

Electrical data

- Electrical hookup: 4-pole connector
- Cable exit: 4 x 0.5 mm²
- Protection class: I

Standards and approvals

- Approvals: CE, EAC

on Page 90	Accessories
on Page 108	Connection diagrams and technical features
on Page 120	Technical parameters and scope
More at	www.ebmpapst.com

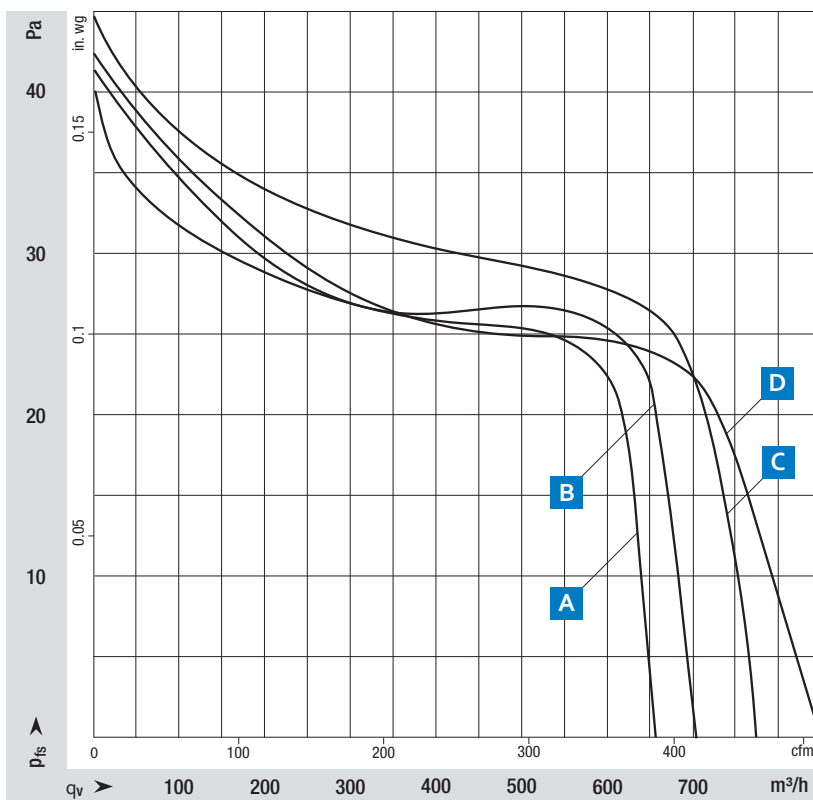

Measuring requirements

Air performance measured according to: ISO 5801, installation category A.

The values given are only applicable under the specified measuring conditions and may differ depending on the installation conditions.

In the event of deviation from the standard configuration, the parameters must be checked in installed condition.

Curve	Nominal voltage VDC	Frequency Hz	Speed n min ⁻¹	Max. input power P _{ed} W	Max. input current I mA	Perm. ambient temp. (1) °C	Conn. diagram
Nominal voltage 24 VDC							
A	24	-	400 – 1400	22	1300	0...+50	iQ2)
B	24	-	400 – 1400	22	1300		
C	24	-	400 – 1400	22	1300		
D	24	-	400 – 1400	22	1300		

Subject to change.

(1) Max. relative humidity 85%, only suitable for applications with no condensation, no water exposure and no corrosion requirements.

Curve	DC tangential fans		
	Type	Part number	Weight kg
A	VTS0080XUHDZ	5566891020	2.60
B	VTS0080XUHDZ	5566892020	2.80
C	VTS0080XUHDZ	5566893020	3.05
D	VTS0080XUHDZ	5566894020	3.30

Specifications apply to products with motor on right. Products with motor on left available on request.

Engineering drawing

Dimensions in mm

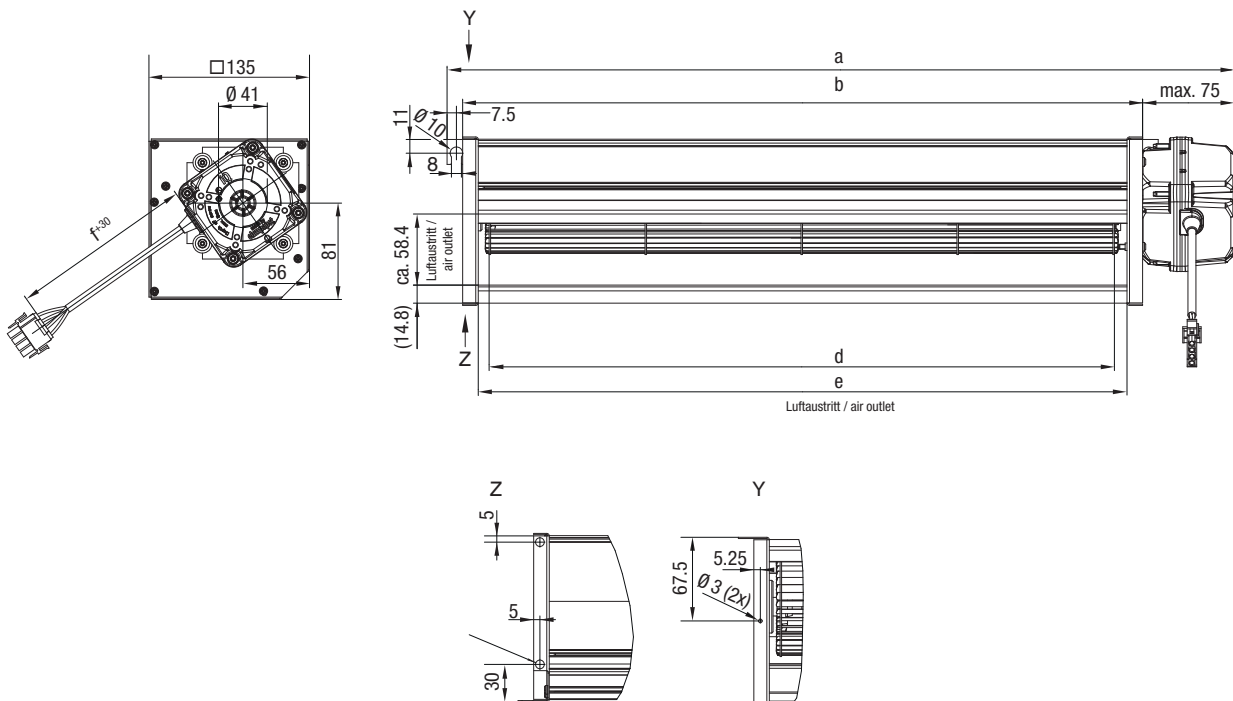

	Dimensions					
	a	b	c	d	e	f
A	max. 635	547.5	max. 75	500	520	150 ⁺³⁰
B	max. 735	647.5	max. 75	600	620	150 ⁺³⁰
C	max. 835	747.5	max. 75	700	720	150 ⁺³⁰
D	max. 935	847.5	max. 75	800	820	150 ⁺³⁰



NiQ motors

ebmpapst

the engineer's choice

	Page
Product information	80
Combination with axial blades	82

NiQ motors



Material/surface

- Housing: plastic (FDA compliant)

Mechanical data

- Direction of rotation: counter-clockwise viewed toward rotor
- Degree of protection: IP 54
- Insulation class: "H"
- Installation position: any
- Mode: continuous operation (S1)
- Mounting: maintenance-free ball bearings

Electrical data

- Motor protection: electronic
- Electrical hookup: cable for connection on motor side (see page 93)
- Protection class: II
- Additional functions: possible on request

Standards and approvals

- Conformity with standards: DIN EN 60335-1; DIN EN 60335-2-24; DIN EN 60335-2-89; CE; UL1004-1; UL1004-7; C22.2 No.77, C22.2 No.100, C22.2 No. 0.1;
- Approvals: VDE; UL; CSA; EAC

on Page 90	Accessories
on Page 108	Connection diagrams and technical features
on Page 120	Technical parameters and scope
More at	www.ebmpapst.com

Additional functions

NiQ reverse on start.

The NiQ reverse on start automatically runs in reverse for a preprogrammed time on starting. An important function for refrigeration devices, as it blows the accumulated dust out of the heat exchanger of the condenser - thus ensuring constant high cooling capacity.

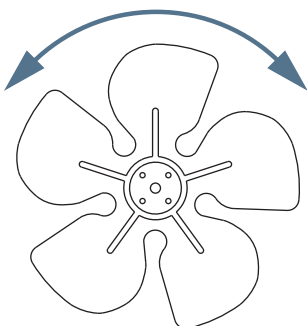

NiQ reverse on demand.

With the NiQ reverse on demand it is possible to define the time and duration of reverse operation as required. This means that the evaporator defrost cycle can be used to remove dust from the heat exchanger of the condenser for example.

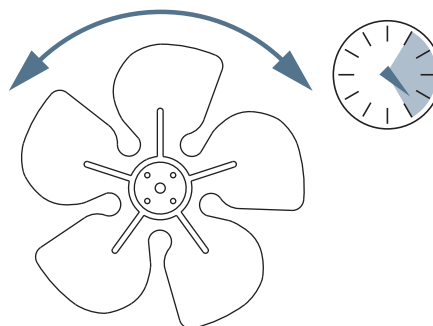

NiQ two speeds.

The particular feature of the NiQ two speeds is that it is supplied with two factory-programmed speed levels. This makes it possible to run the application in different day and night modes for even greater energy savings.

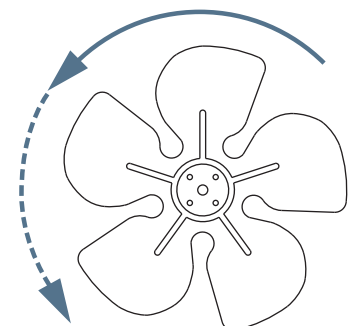

Type	Part number	Voltage VAC	Frequency Hz	Speed rpm	Max. input power W	Perm. ambient temp. °C	Weight kg	Conn. diagram	Maße (in mm)				
									A	B ⁽¹⁾	C ⁽²⁾	D	E
DE032BNKXX0S	5533201001	220-240	50/60	1300	9	-40.. +50	0.38	NiQ1)	49	74.0	79.0	30.5	43.5
	5533201004	100-240	50/60	1550	9	-40.. +50	0.38		49	74.0	79.0	30.5	43.5
DE032CNKXX0S	5533202007	220-240	50/60	1300	25	-40.. +50	0.46		49	82.0	87.0	30.5	43.5
	5533202011	100-240	50/60	1550	25	-40.. +50	0.46		49	-	87.0	30.5	43.5
DE032ENKXX0S	5533203006	220-240	50/60	1300	30	-40.. +50	0.62		54	91.5	96.5	38.5	43.5/51.5
	5533203007	100-240	50/60	1550	30	-40.. +50	0.62		54	-	96.5	38.5	43.5/51.5

Subject to change.

⁽¹⁾ Standard cover ⁽²⁾ Cover with blind holes

Engineering drawing

Dimensions in mm

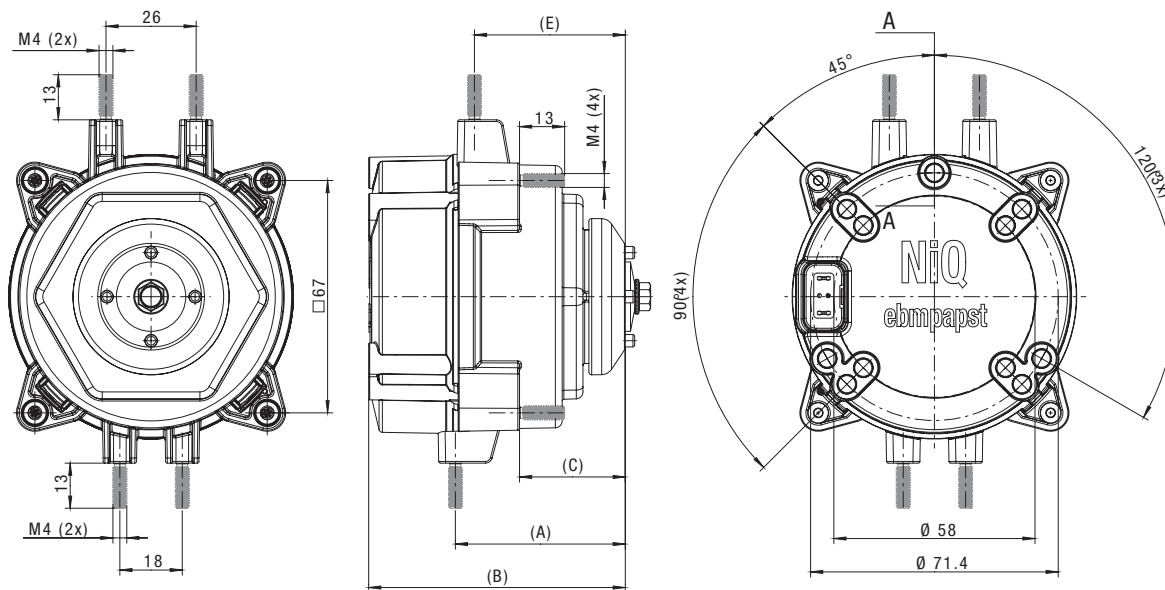

Cover with blind holes,
suitable for self-cutting screws

Standard cover, suitable for (M4)
threaded insert epL P/N 27450.19112

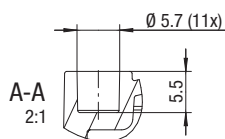
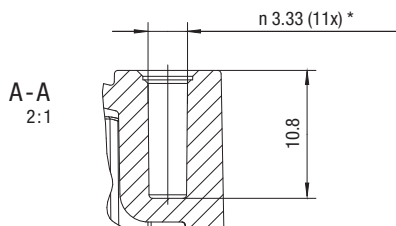

Side mounting pins are available on request.
Prepared for fan housing mounting.

NiQ: Combination with axial blades

Input power and airflow

NiQ motors

Motor	Axial blade diameter mm	Axial blade angle °	Family of curves	Input power W	Output power W	Air flow, free air at n = 1300 rpm m³/h	Family of curves	Input power W	Output power W	Air flow, free air at n = 1550 rpm m³/h
NiQ 3208 at 1300 rpm							NiQ 3208 at 1550 rpm			
	154	22		2.6	1.7	165		3.5	1.8	195
	154	28	A	2.9	1.9	175	A	4.0	2.1	215
	154	34		3.6	2.3	215		5.0	2.6	365
	172	22		2.9	1.9	205		4.1	2.0	250
	172	28	B	4.1	2.7	265	B	6.0	3.2	325
	172	34		5.4	3.5	310		8.3	4.7	385
	200	22	C	4.7	3.1	335	C	–	–	–
	200	28		6.0	3.8	385		–	–	–
NiQ 3212 at 1300 rpm							NiQ 3212 at 1550 rpm			
	200	22		3.9	2.6	330		6.0	3.8	400
	200	28	D	5.1	3.5	380	D	7.7	5.0	470
	200	34		6.7	4.6	460		11.0	7.3	555
	230	22		8.4	5.6	580		14.0	9.6	675
	230	28	E	12.7	8.4	690	E	20.9	13.2	820
	230	34		18.1	11.4	825		–	–	–
	254	22	F	11.2	7.6	735	F	–	–	–
NiQ 3224 at 1300 rpm							NiQ 3224 at 1550 rpm			
	230	34	G	16.3	11.4	850	G	26.5	19.2	1000
	254	22		10.8	7.6	750		17.2	12.2	920
	254	28	H	18.6	13.4	970	H	30.5	21.1	1160
	254	34		26.2	18.8	1095		–	–	–

All values determined for air flow direction "V". Power consumption and output power determined without fan housing. Air flow determined with fan housing.

NiQ: Combination with axial blades

Air performance curves determined in fan housing, at a constant speed of 1300 rpm.

Family of air performance curves at 1300 rpm

NiQ 3208 with axial blades Ø 154 mm

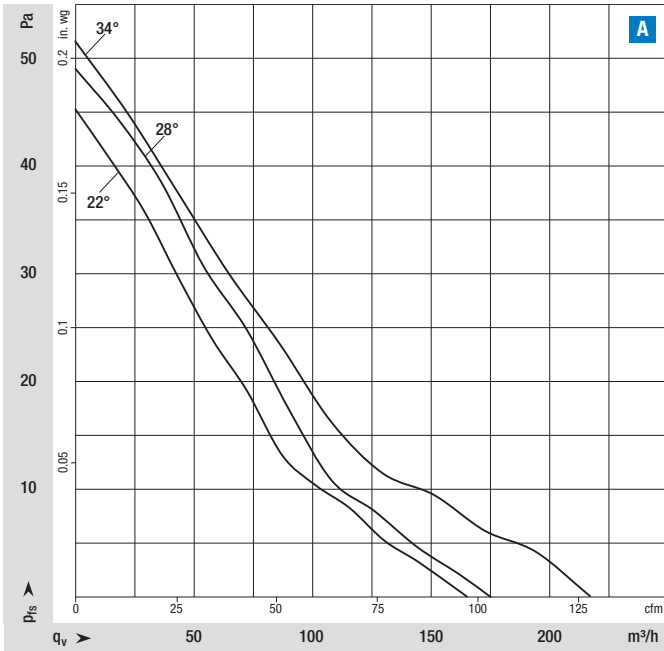

NiQ 3208 with axial blades Ø 172 mm

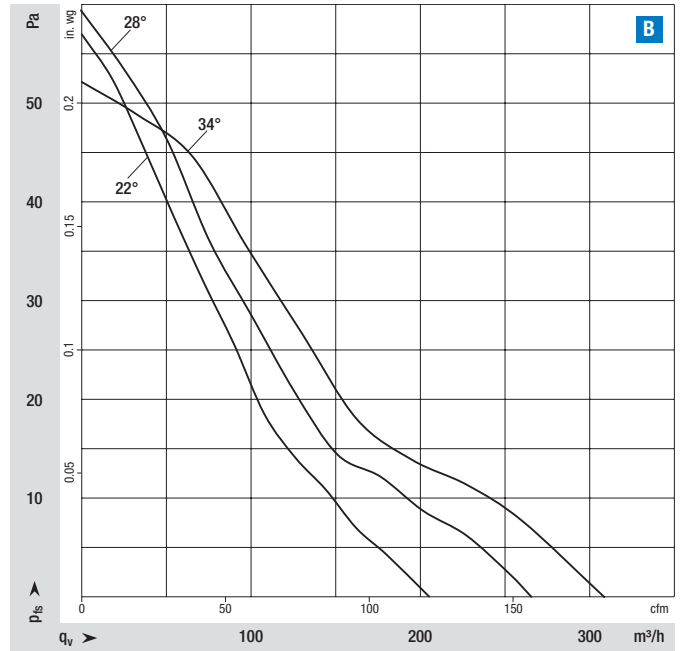

NiQ 3208 with axial blades Ø 200 mm

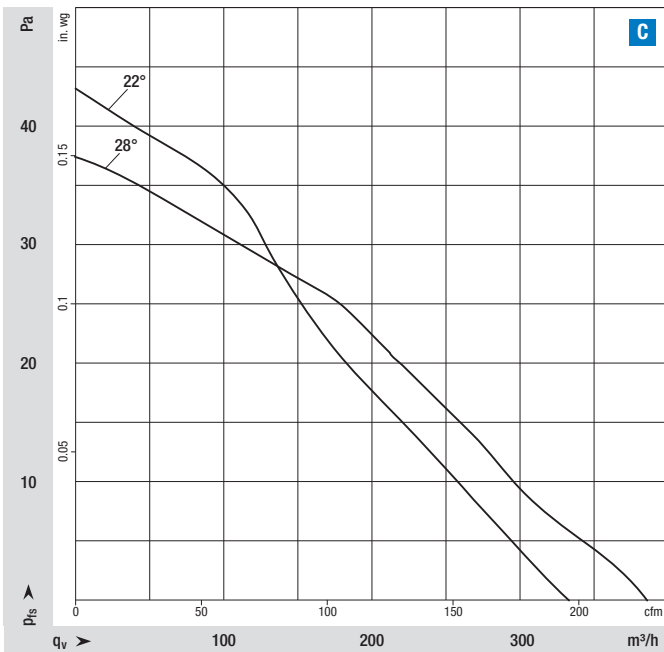

NiQ: Combination with axial blades

Air performance curves determined in fan housing, at a constant speed of 1550 rpm.

Family of air performance curves at 1550 rpm

NiQ 3208 with axial blades Ø 154 mm

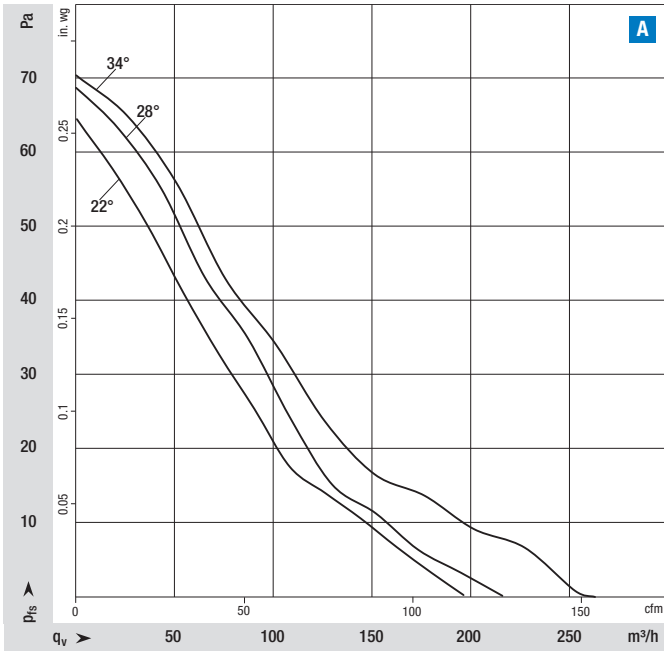

NiQ 3208 with axial blades Ø 172 mm

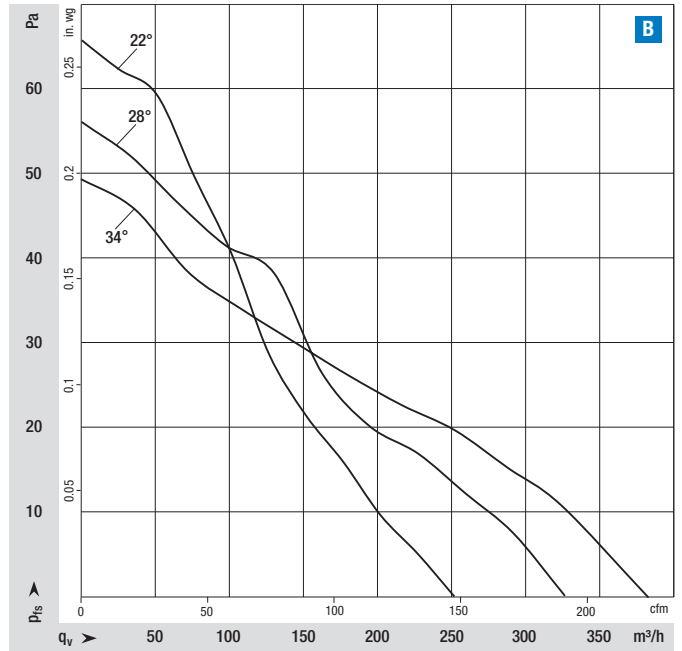

NiQ 3208 with axial blades Ø 200 mm

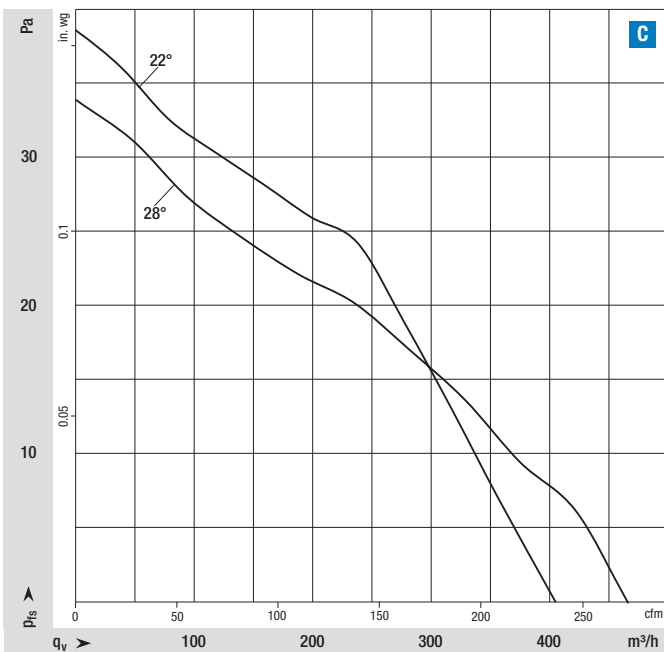

NiQ: Combination with axial blades

Air performance curves determined in fan housing, at a constant speed of 1300 rpm.

Family of air performance curves at 1300 rpm

NiQ 3212 with axial blades Ø 200 mm

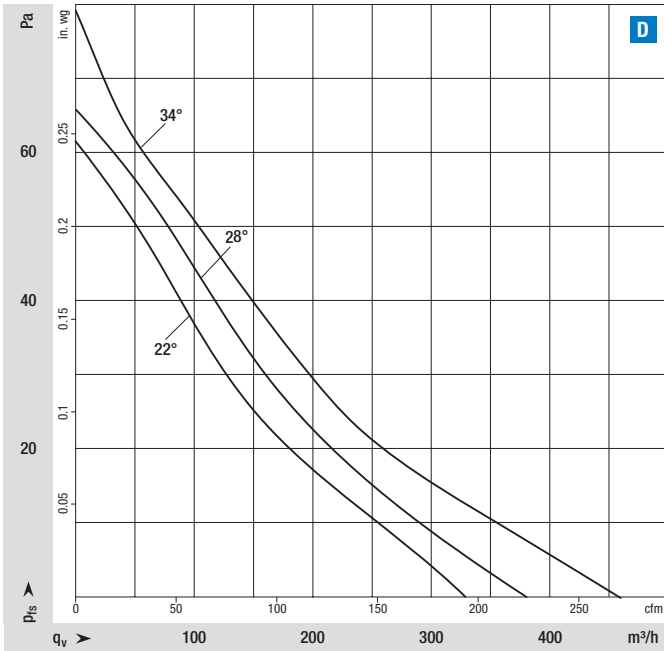

NiQ 3212 with axial blades Ø 230 mm

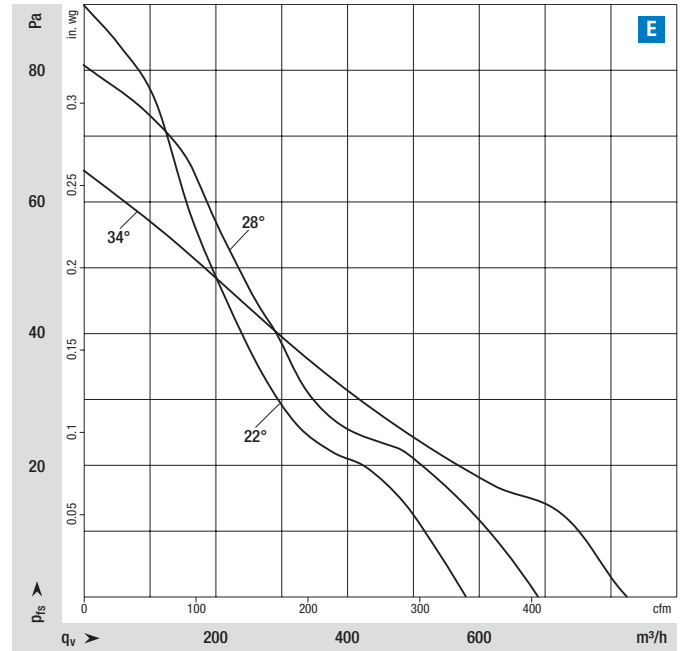

NiQ 3212 with axial blades Ø 254 mm

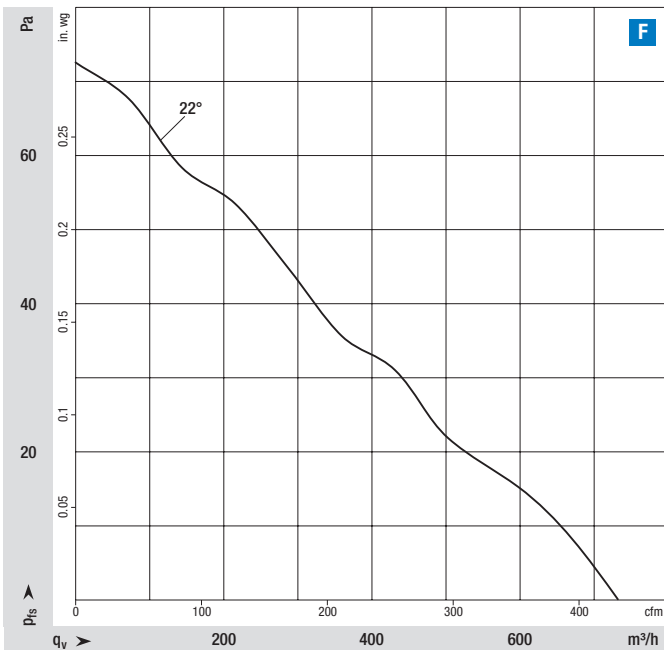

NiQ: Combination with axial blades

Air performance curves determined in fan housing, at a constant speed of 1550 rpm.

Family of air performance curves at 1550 rpm

NiQ 3212 with axial blades Ø 200 mm

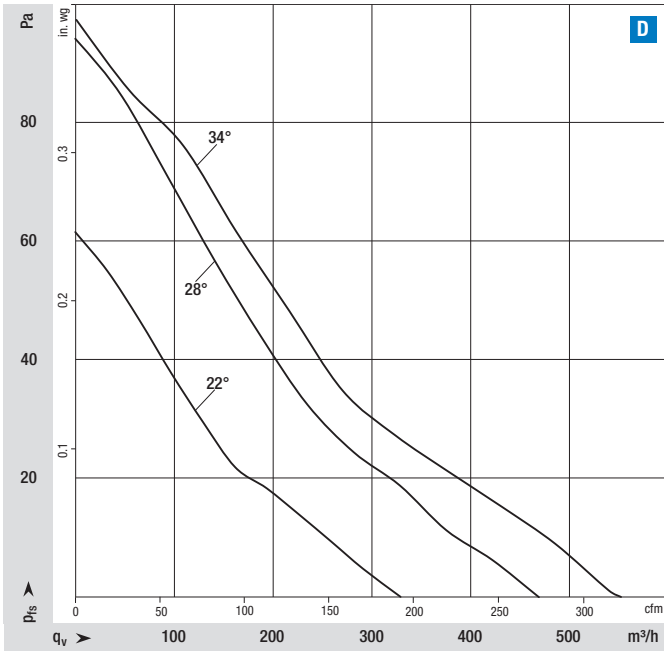

NiQ 3212 with axial blades Ø 230 mm

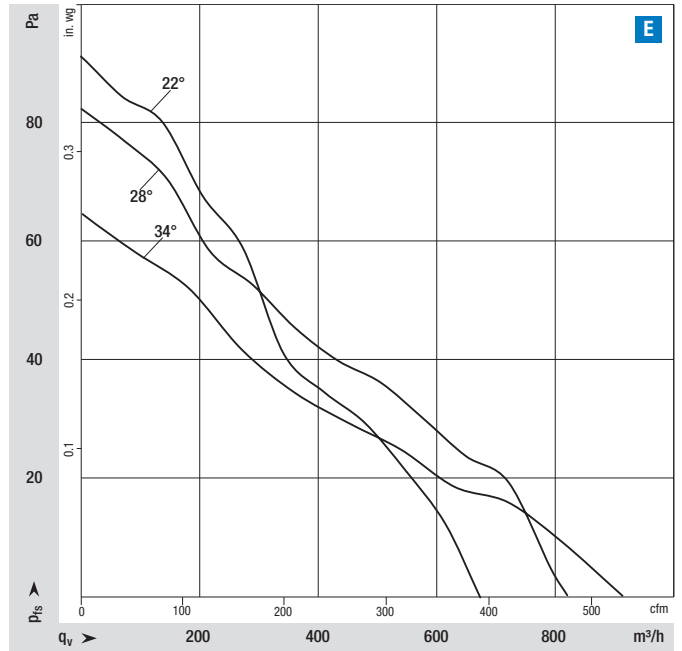

NiQ 3212 with axial blades Ø 254 mm

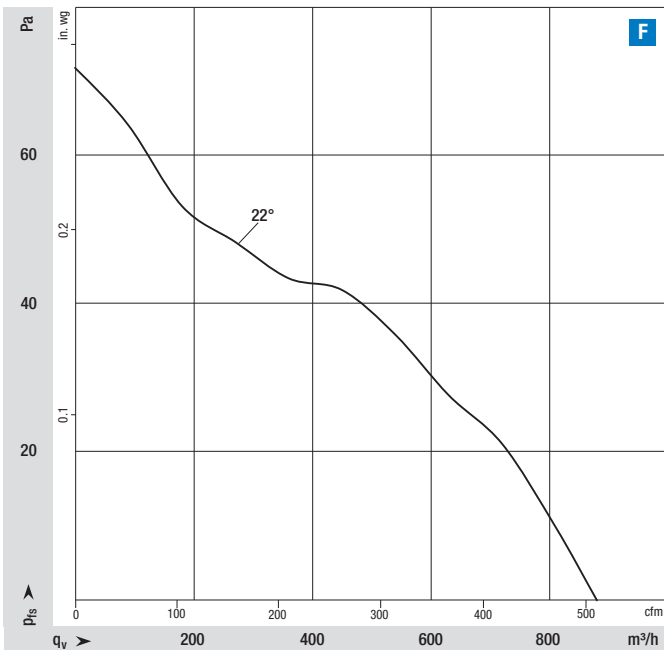

NiQ: Combination with axial blades

Air performance curves determined in fan housing, at a constant speed of 1300 rpm.

Family of air performance curves at 1300 rpm

NiQ 3224 with axial blades Ø 230 mm

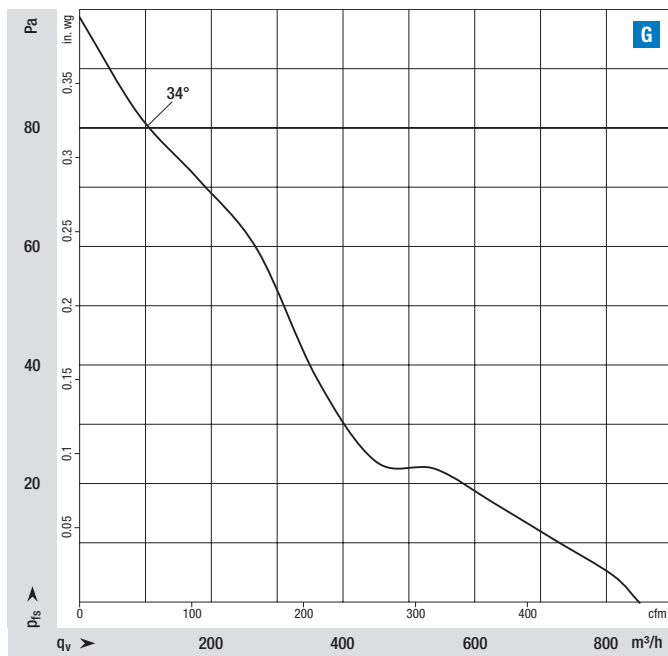

NiQ 3224 with axial blades Ø 254 mm

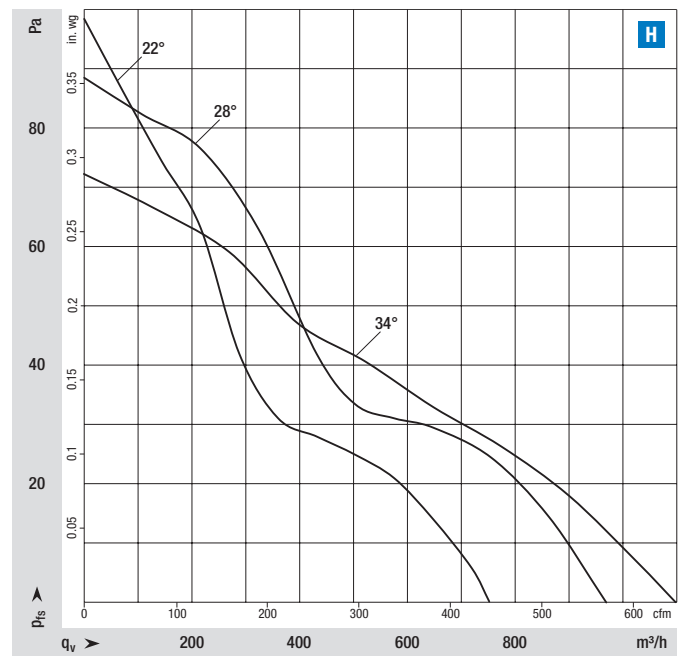

NiQ: Combination with axial blades

Air performance curves determined in fan housing, at a constant speed of 1550 rpm.

Family of air performance curves at 1550 rpm

NiQ 3224 with axial blades Ø 230 mm

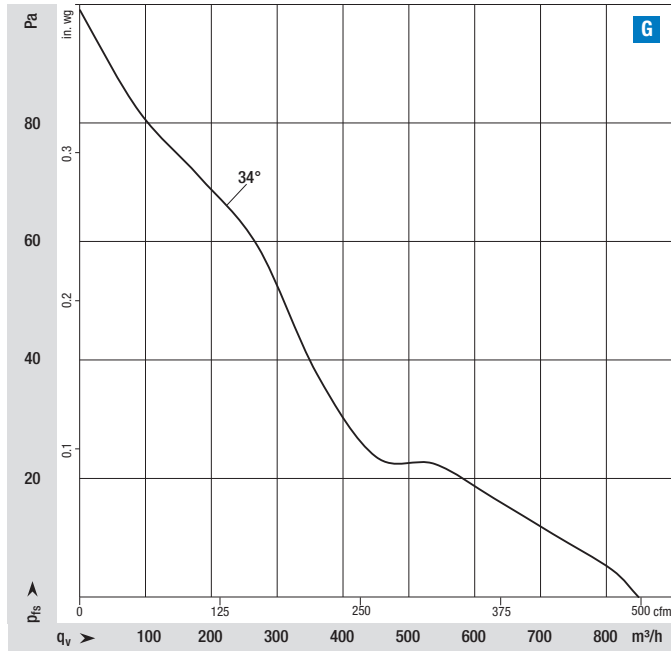

NiQ 3224 with axial blades Ø 254 mm

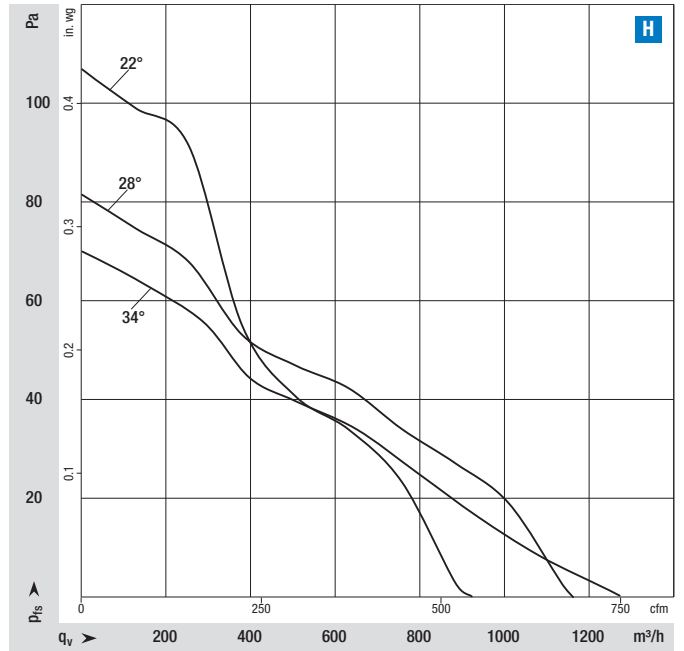



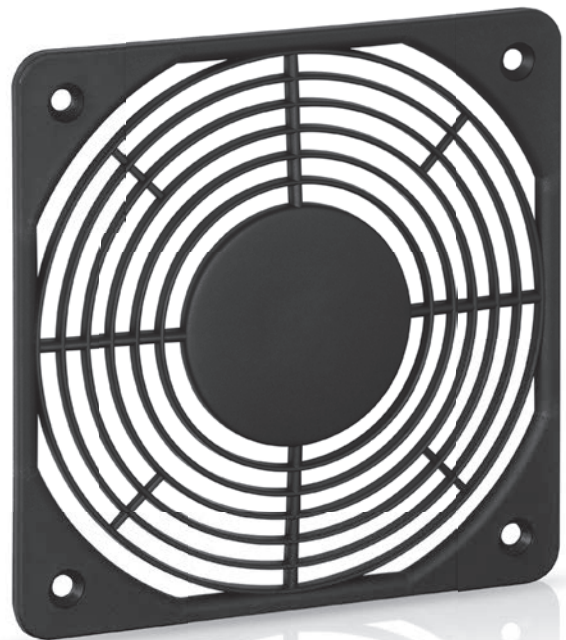

Accessories

for refrigerated display cases

ebmpapst

the engineer's choice

	Page
Cables	92
Hand-held programmer	94
Plug-in module	95
Air-inlet grille	96
Guard grilles	98
Axial impellers	102
Mounting brackets	103
Fan housings	104

Cables

for axial and diagonal fans

Fully encapsulated ESM motor connector

Part number	a (mm)	115/230 VAC 2-wire	115/230 VAC 3-wire	24 VDC 4-wire	Hose
15201-4-1040	450	X			
15202-4-1040	1500	X			
15203-4-1040	2000	X			
11200-4-1040	450		X		UL-compliant cable, connector sealed. Customized cables possible.
11205-4-1040	600		X		
11202-4-1040	1500		X		
11204-4-1040	2000		X		
10710-4-1040	450			X	
10711-4-1040	1500			X	

Subject to change
Not for W1G130-AA49-01 and W1G130-AA25-01.
Customized versions possible on request.

115/230 VAC
2-wire

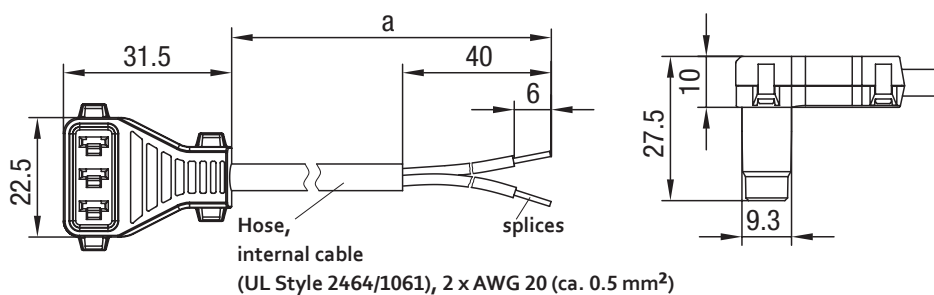

115/230 VAC
3-wire

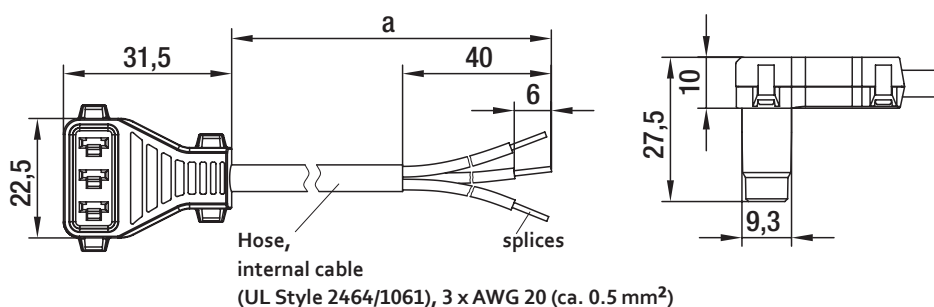

24 VDC
4-wire

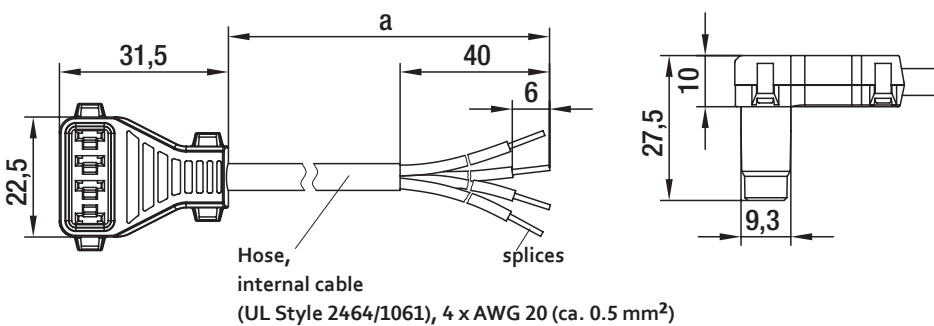

Cables

for NiQ motors

Standard circuit connections

Part number	a (mm)	2-wire	3-wire	Hose
27450.62327	480	X		
27450.62329	1000	X		H03VV (0.5 mm ²)
27450.62330	1500	X		
27450.62331	480	X		
27450.62332	1000	X		UL2517 (AWG 20)
27450.62333	1500	X		
27450.62337	480		X	
27450.62338	1000		X	H03VV (0.5 mm ²)
27450.62339	1500		X	
27450.62334	480		X	
27450.62335	1000		X	UL2517 (AWG 20)
27450.62336	1500		X	

Subject to change.
Customized versions possible on request.

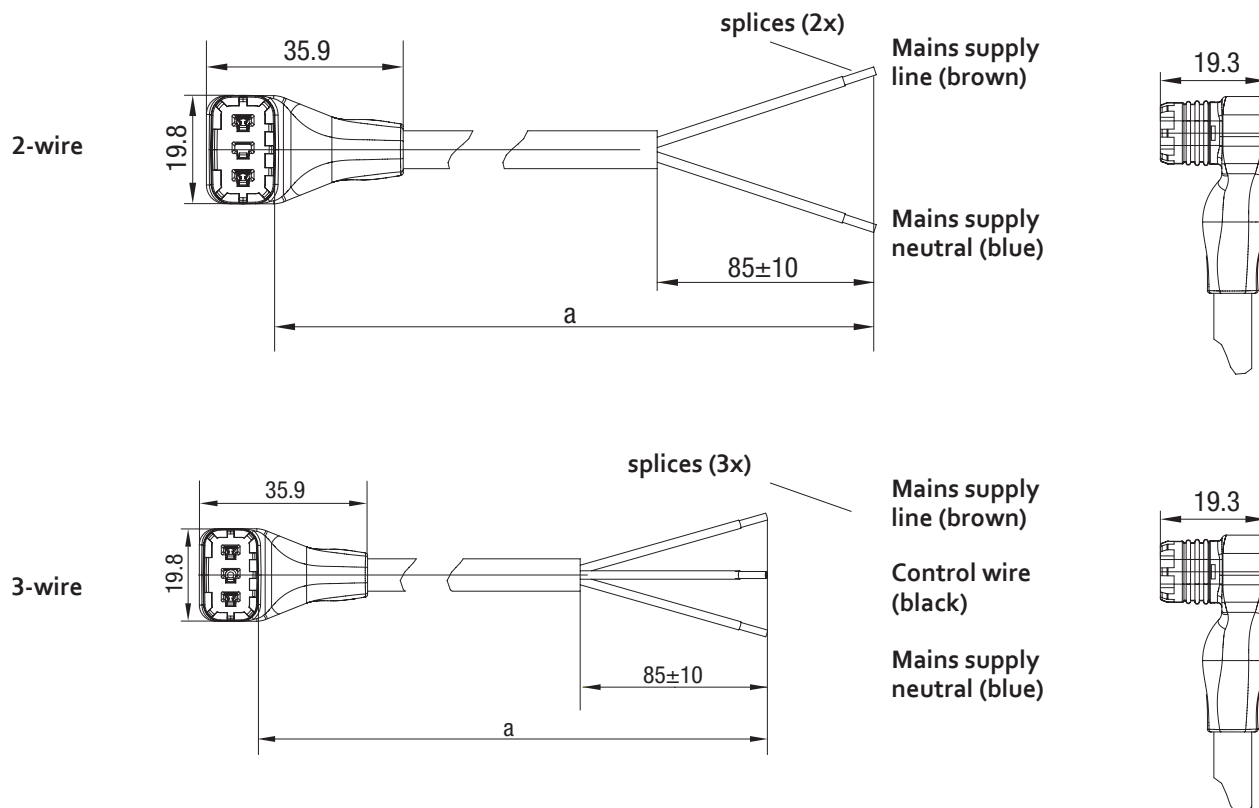

Hand-held programmer

Hand-held programmer for products based on energy-saving motor (ESM)

Part number	Design
CBC000AF0801	Simple speed programming, battery-operated User-friendly navigation menu, protective case with folding stand

Subject to change.
Extension for models ESM+ only.

Replacement programming cable for hand-held unit

Part number	Length (mm)
29005-4-1040	1000

Subject to change.



Extremely simple programming of the two rotational speeds which can be set under ESM. Eliminates the need for a PC, software, power adapter and second cable. Specially for use in production or in the field. Automatic switch-off function for a longer battery life. Mini-USB connector for downloading software updates. Batteries, programming cable and operating instructions included in scope of delivery.

See Page 80 for different modes of operation.

Plug-in module

External electronics / ESM plug-in module

Part number	Design
CCC000AE0907	115 V, 50/60 Hz, control curve 1 V - 10 V => 10 % - 100 %, length control line: 1000 mm, length supply line: 450 mm
CCC000AE0806	230 V, 50/60 Hz, control curve 1 V - 10 V => 10 % - 100 %, length control line: 1000 mm, length supply line: 450 mm
CCC000AE0810	230 V, 50/60 Hz, control curve 1 V - 10 V => 10 % - 100 %, length control line: 3000 mm, length supply line: 3000 mm

Subject to change.
Extension for models ESM+ only.



The plug-in module extends the ESM product range with the addition of a 0-10V control input and can be retrofitted for the programmable ESM fans in this catalog. Compatible fans can be recognized from the "ESM+ enabled" label.

Air-inlet grille FlowGrid



The air performance of ebm-papst fans is not the only thing measured on the state-of-the-art, in-house test stand.

The acoustic behavior of the fans is also examined and the measuring results are included in the technical documentation. Please note that the measurements are taken under ideal conditions with undisturbed inflow and outflow.

If the fans are later installed in applications where limited space is available, the noise information listed in the documentation will probably not be applicable.

In order to minimize the negative impact of the installation situation, ebm-papst offers the Flow-Grid airinlet guard shown here.

It is mounted on the fan's intake side and effectively reduces the noise in the fan's overall frequency range; especially the disturbing tonal noise in the low frequency range.

The result is a far lower sound pressure level and pleasant running noise.

Since the level of noise reduction is dependent on the installation circumstances, it is not possible to provide generally applicable information here.

Air-inlet grille FlowGrid

Part number	Fan size	Ø B (mm)	Ø C (mm)	Ø E (mm)	S (mm)	H (mm)	N* (mm)
00250-2-2957	200	205	193	4.5	2.0	37.7	1 ^{+0.2} Nm

Subject to change.
Only for K1G200-AA95-02 and K1G200-AA73-02.

* recommended tightening torque for fastening screws

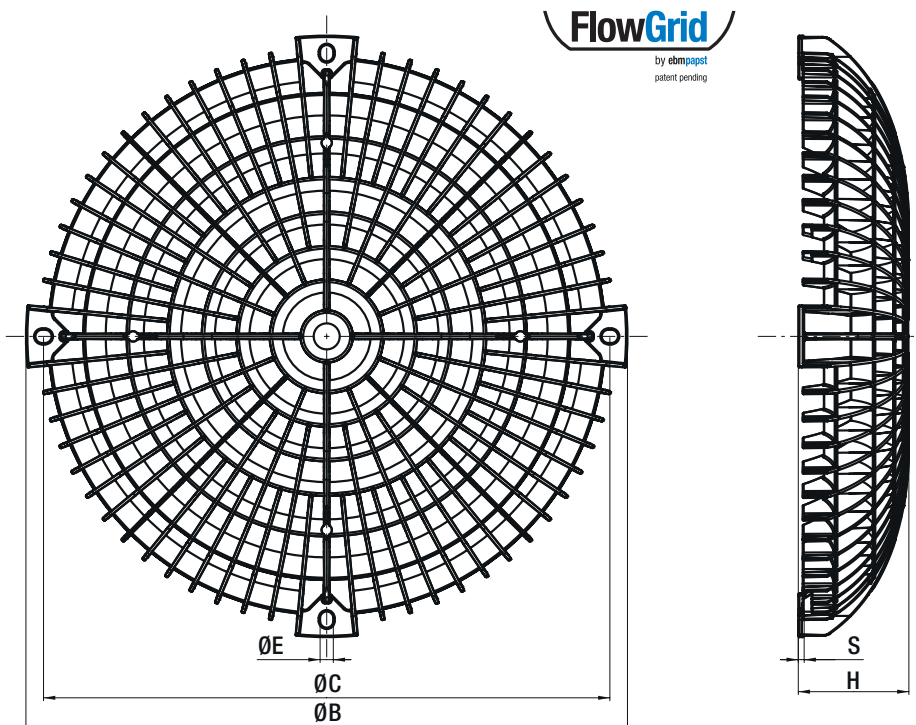

Would you like to find out more?

If you need an installation guide or more information about the dimensions, go to:

www.ebmpapst.com/flowgrid-manual

or scan the QR code below:



Air-inlet grille FG 119



Material/surface

- PA plastic, fiberglass-reinforced

Note

- For axial and diagonal fans
- Assembled on the air intake, the fan grid reduces the noise emission dramatically and minimizes disturbing low frequency sound

Side

- Intake side

Air-inlet grille

Part number	Fan size	□ B (mm)	□ C (mm)	∅ E (mm)	S (mm)	H (mm)	Fan series
9920070000	119 x 119	119 ^{+0.3}	104.8	4.3 ^{+0.15}	2 ^{+0.2}	32.62 ^{+0.3}	ACi 4400 N, ACi 4400, 4300 N

Subject to change.

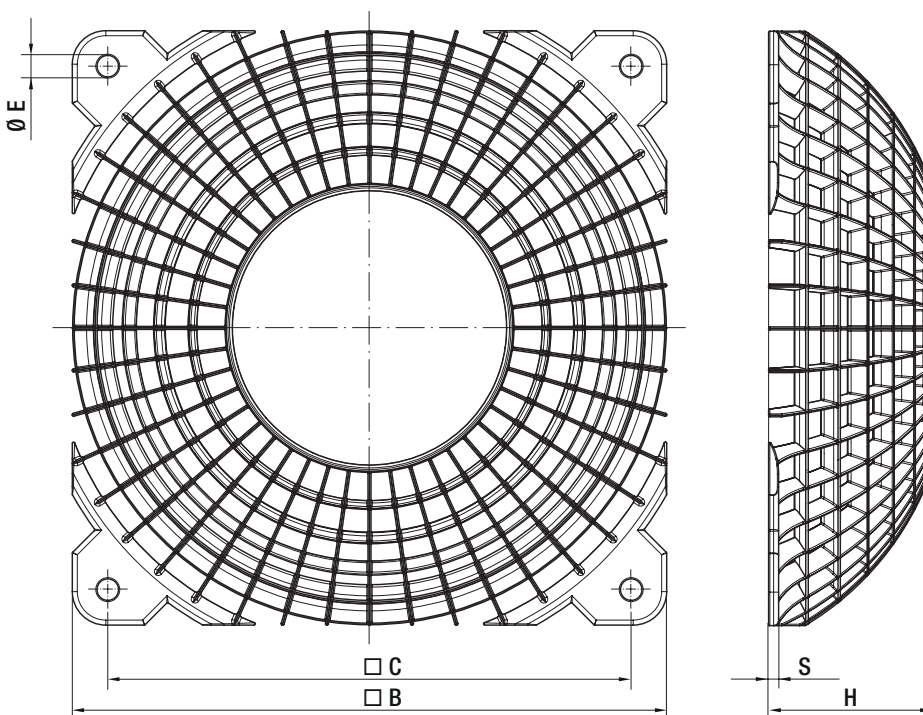

Guard grilles

for compact fans



Material/surface

- Galvanized or nickel-plated steel wire

Note

- Guard grilles according to DIN EN ISO 13857 (previously EN 294).
- Additional guard grilles that do not satisfy DIN EN ISO 13857 available on request.
- Our guard grilles are designed specifically to be used with ebm-papst fans. They combine the highest degree of safety with minimum effect on the operating noise. Please note that the safety-related clearances cannot be guaranteed when guard grilles made by other manufacturers are used.

Guard grilles

Part number	Type	Fan size	Fan series	Side
9920022002	LZ22-2	80 x 80	8300 N	Intake/Outlet
9920032004	LZ32-4			
9920022001	LZ22-N			
9920145006	LZ32-14			
9920023000	LZ23	92 x 92	3300 N	Intake/Outlet
9920023001	LZ23-1			
9920020000	LZ20			
9920030000	LZ30	119 x 119	4300 N	Intake/Outlet
9920030003	LZ30-3			
9920030004	LZ30-4			

Subject to change.

Engineering drawing

Dimensions in mm

LZ22-2

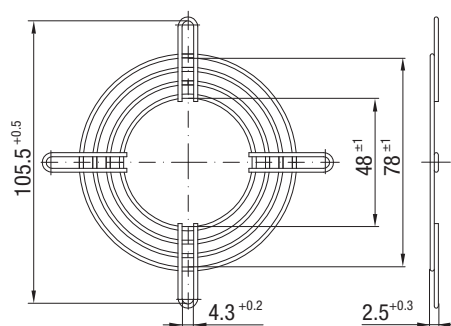

LZ32-4

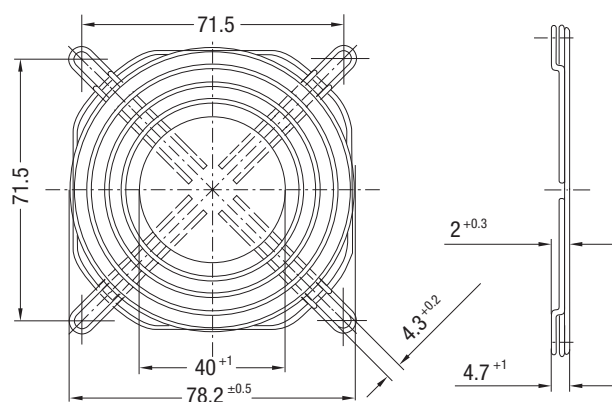

LZ22-N

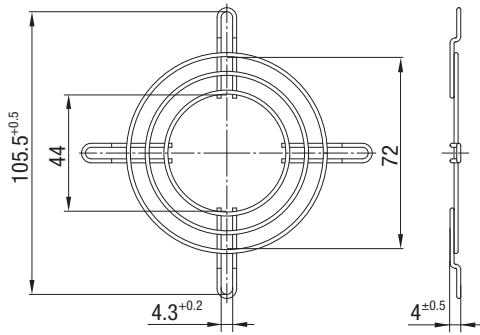

LZ32-14

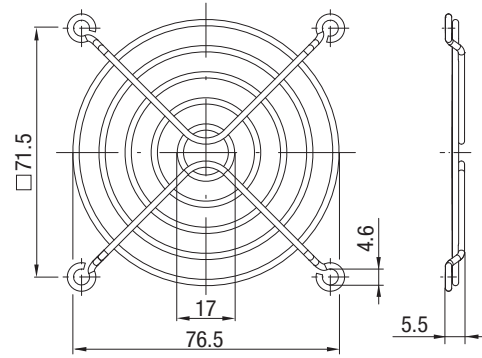

LZ23

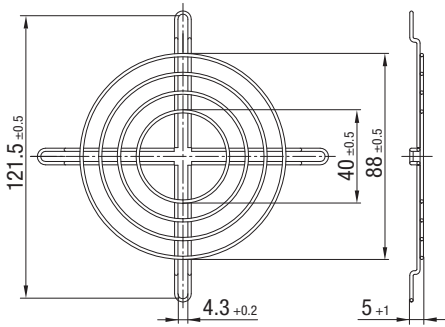

LZ23-1

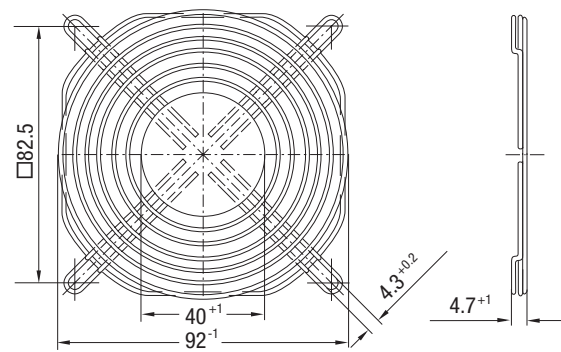

LZ20

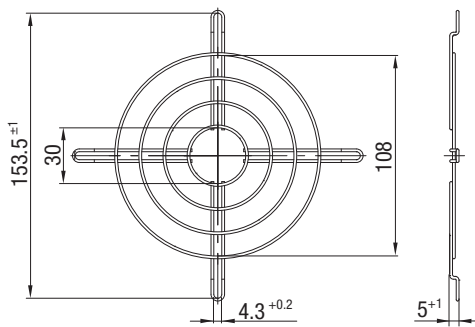

LZ30

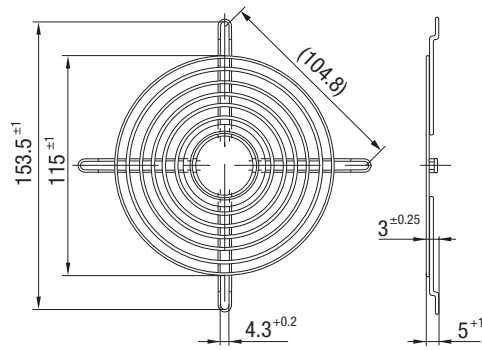

LZ30-3

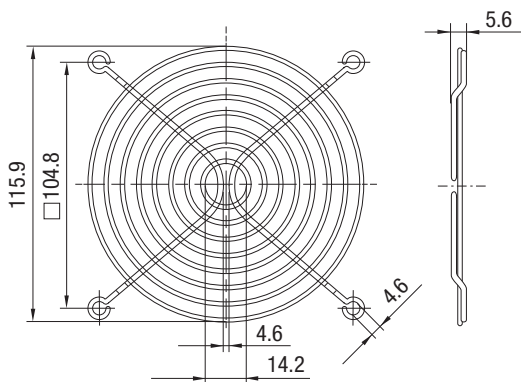

LZ30-4

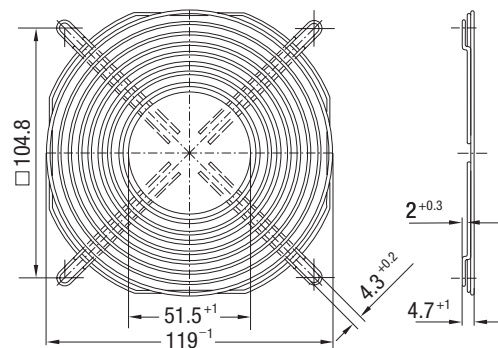

Guard grilles

for compact fans



Material/surface

- Fiberglass-reinforced plastic

Note

- Guard grilles according to DIN EN ISO 13857 (previously EN 294)

Guard grilles

Part number	Type	Fan size	Fan series	B (mm)	C (mm)	D (mm)	E (mm)	Mounting
9920032002	LZ32-2							A1
9920032003	LZ32-2	80 x 80	8300 N	80 ^{-0.5}	71.5 ^{+0.2}	7.0	34	A3
9920032001	LZ32-P							A2
9920023002	LZ23-2							A1
9920023003	LZ23-3	92 x 92	3300 N	92 ^{-0.5}	82.5 ^{+0.2}	6.5	46	A3
9920030005	LZ30-5							A2
9920030006	LZ30-6	119 x 119	ACi 4400 N, ACI 4400, 4300	119 ^{-0.5}	105 ^{+0.2}	6.5	50	A4
9920030001	LZ30-P							A2

Subject to change.

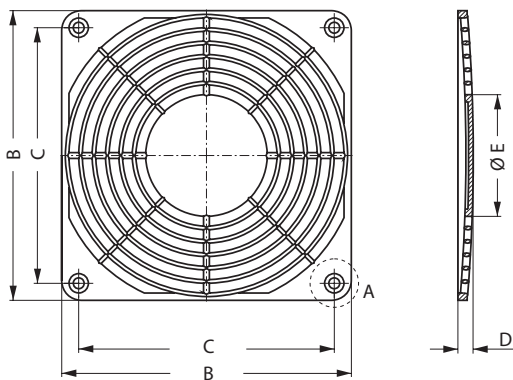

Screw connection

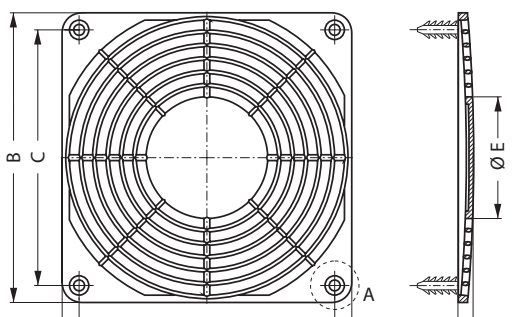
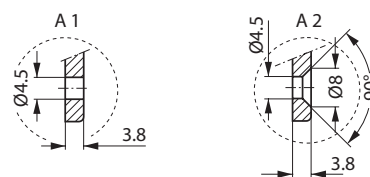

Barbed inserts

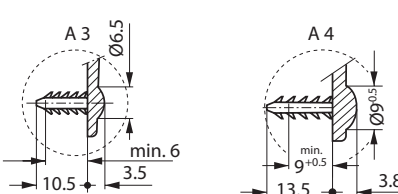

Guard grilles

for NiQ motors

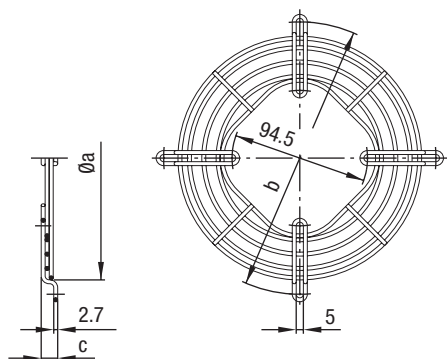

Material/surface

- Steel, galvanized and blue chromated

Guard grilles

Part number	Size	Max. blade angle α at "V"	Max. blade angle α at "A"	a (mm)	b (mm)	c (mm)
27452.70002	154	34°	34°	170.0	190.0	11.5
27452.70003	172	34°	34°	188.0	208.0	11.5
27452.70004	200	34°	34°	214.0	236.0	11.5
27452.70005	230	28°	28°	246.0	266.0	17.5
27452.70006	254	28°	28°	270.0	290.0	17.5
27452.70007	300	–	22°	324.0	344.0	17.5

Subject to change.

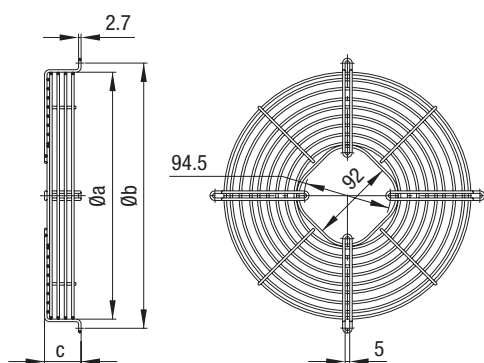

Material/surface

- Steel, galvanized and blue chromated

Basket guard grilles

Part number	Size	Max. blade angle α at "V"	Max. blade angle α at "A"	a (mm)	b (mm)	c (mm)
27452.70201	172	34°	34°	188.0	208.0	37.5
27452.70202	200	34°	28°	212.0	236.0	37.5
27452.70203	230	28°	28°	246.0	266.0	40.0
27452.70204	254	28°	28°	270.0	290.0	40.0
27452.70205	300	–	22°	325.0	344.0	46.8

Subject to change.

Axial impellers

for NiQ motors

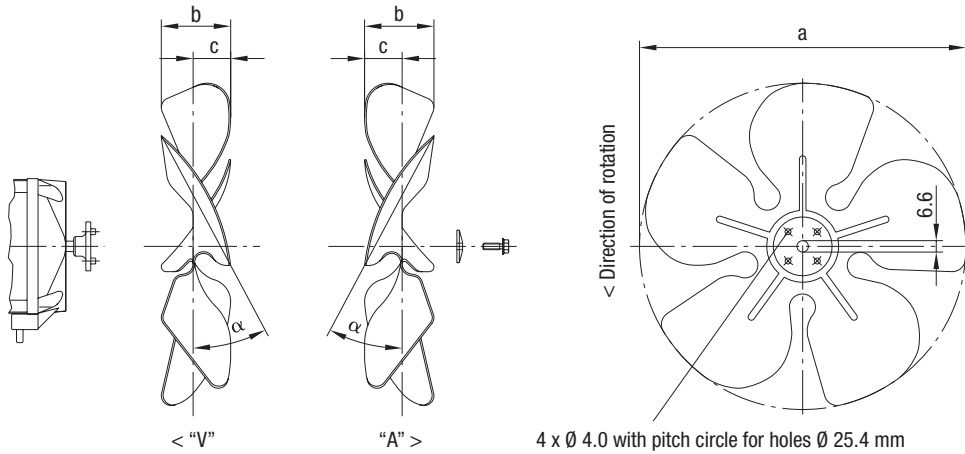

Axial impellers

Part number for direction of airflow "V"	Part number for direction of airflow "A"	Blade angle α	a (mm)	b (mm)	c (mm)
27453.34001	27453.34201	22°	154.0	27.5	14.0
27453.34002	27453.34202	28°	154.0	32.0	16.0
27453.34003	27453.34203	34°	154.0	37.0	18.0
27453.34004	27453.34204	22°	172.0	31.0	14.5
27453.34005	27453.34205	28°	172.0	36.0	17.0
27453.34006	27453.34206	34°	172.0	42.0	21.0
27453.34007	27453.34207	22°	200.0	32.0	15.5
27453.34008	27453.34208	28°	200.0	37.5	18.0
27453.34009	27453.34209	34°	200.0	45.0	22.0
27453.34010	27453.34210	22°	230.0	35.0	17.5
27453.34011	27453.34211	28°	230.0	43.0	21.5
27453.34012	27453.34212	34°	230.0	50.0	24.0
27453.34013	27453.34213	22°	254.0	37.0	19.0
27453.34014	27453.34214	28°	254.0	45.0	23.5
27453.34015	27453.34215	34°	254.0	52.0	26.0
27453.34016	27453.34216	22°	300.0	43.0	21.5
27453.34017	27453.34217	28°	300.0	53.5	26.5
27453.34018	27453.34218	34°	300.0	61.0	30.0

Subject to change.

Mounting brackets

for NiQ motors

Material/surface

- Steel, galvanized and blue chromated

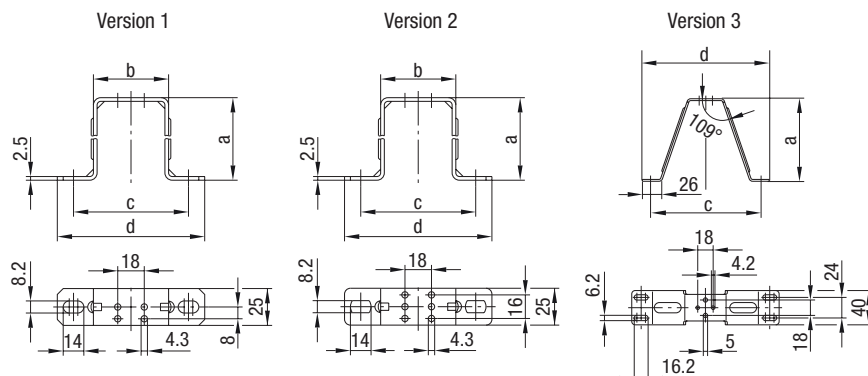

Mounting brackets – foot measure 18 mm (multi-function design)

Part number	Size	Version	a (mm)	b (mm)	c (mm)	d (mm)
27452.71002	172	1	56.0	51.0	78.0	100.0
27452.71005	200	2	67.0	51.0	78.0	100.0
27452.71003	230	1	74.5	51.0	78.0	100.0
27452.71004	254	2	85.5	51.0	78.0	100.0
27452.71001	300	3	112.0	–	150.0	172.0

Subject to change.

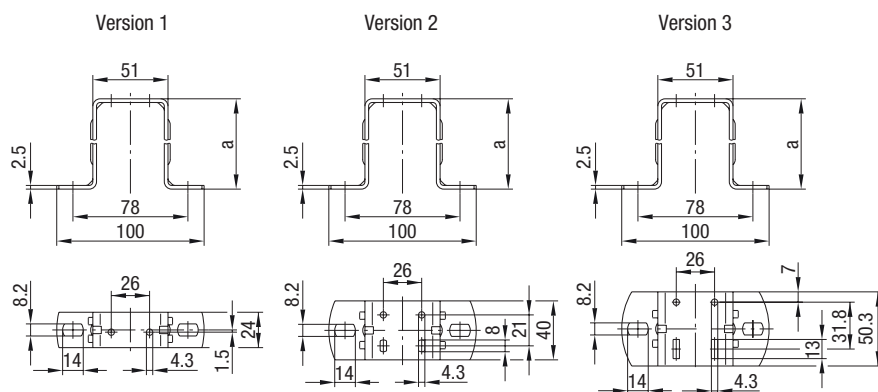

Mounting brackets – foot measure 26 mm (standard design or multi-function design)

Part number	Size	Version	a (mm)
27452.71201	154	1	39.0
27452.71202	172	1	52.0
27452.71203	200	1	72.0
27452.71204	254	1	84.0
27452.71205	254	2	84.0
27452.71206	300	2	109.0
27452.71207	300	3	109.0

Subject to change.

Fan housings

for NiQ motors

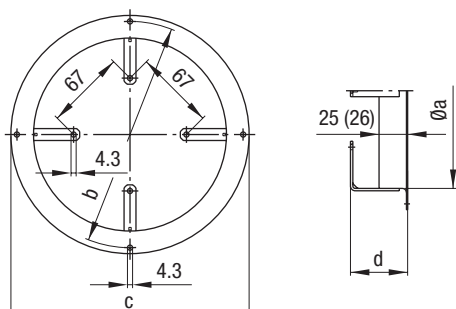

Material/surface

- Sheet steel, coated in grey plastic

Fan housings, direction of airflow "V"

Part number (sheet steel)	Part number (plastic) ¹⁾	Size	Max. blade angle α	a (plastic) (mm)	b (plastic) (mm)	c (mm)	d (plastic) (mm)
27452.70501	27452.70802	154	34°	164.0 (167.5)	190.0 (191.0)	200.0	48.0 (46.0)
27452.70502	27452.70803	172	34°	182.0 (184.5)	208.0	223.0	49.0 (46.0)
27452.70503	27452.70804	200	34°	210.0 (214.5)	236.0	246.0	48.5 (46.5)
27452.70504	–	230	28°	242.0	266.0	276.0	49.0
27452.70505	27452.70805	254	28°	264.0 (269.5)	290.0	300.0	48.0 (50.5)
27452.70506	27452.70806	300	22°	308.0 (315.0)	344.0	356.0	49.0 (50.5)

Subject to change.

¹⁾ Block diagram. Design may differ depending on version.

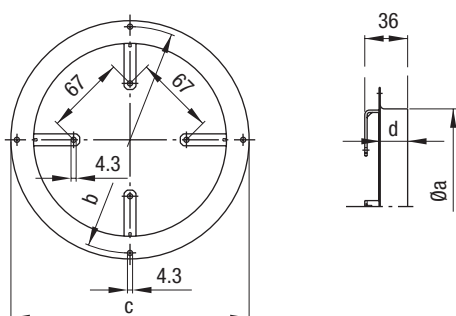

Material/surface

- Sheet steel, coated in grey plastic

Fan housings, direction of airflow "A"

Part number (sheet steel)	Part number (plastic) ¹⁾	Size	Max. blade angle α	a (plastic) (mm)	b (mm)	c (plastic) (mm)	d (plastic) (mm)
27452.70701	–	154	34°	162.0	190.0	200.0	24.0
27452.70702	–	172	34°	180.0	208.0	223.0	24.0
27452.70703	–	200	28°	208.0	236.0	246.0	24.0
27452.70704	–	230	28°	242.0	266.0	276.0	25.5
27452.70705	27452.70807	254	28°	262.0 (269.0)	290.0	300.0 (302.0)	24.0 (44.0)
27452.70706	–	300	22°	308.0	344.0	356.0	29.0

Subject to change.

¹⁾ Block diagram. Design may differ depending on version.

Fan housing types

for axial fans

Type A: Round fan housing

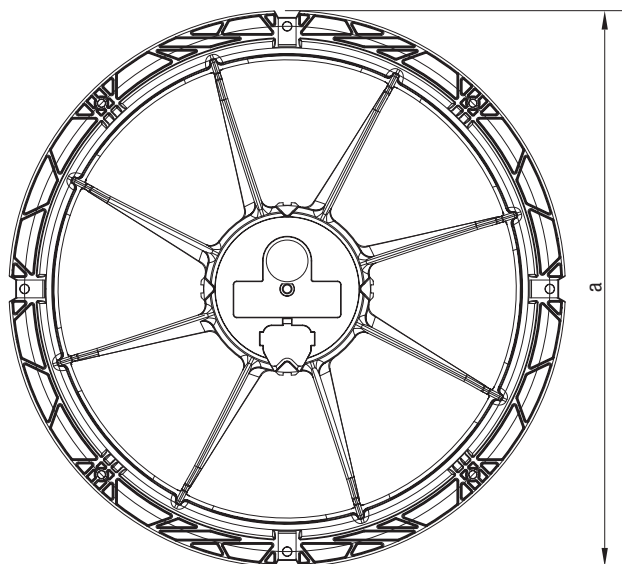

Type B: Flat-type fan housing

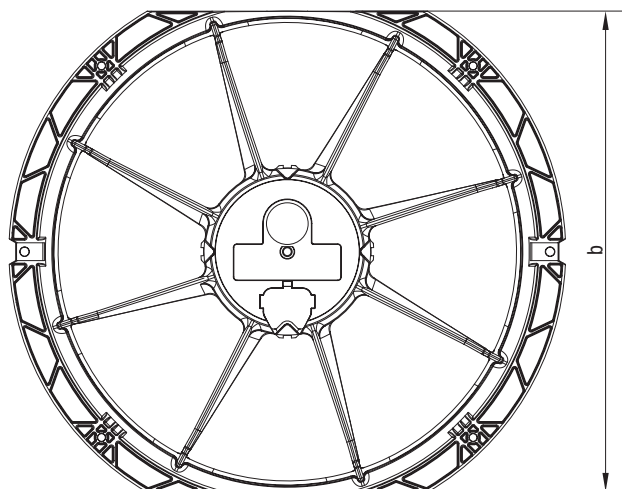

The following axial fans are also available with flat-type fan housing (type B):

Fan housing types for axial fans

Part number	Fan size	a (mm)	b (mm)
W1G154EG5701	154	200	180
W1G154EG5702	154	200	180
W1G154EG5705	154	200	180
W1G172EC8280	172	222	202
W1G172EC9501	172	222	202
W1G172EC9101	172	222	202
W1G200EG5701	200	250	230
W1G200EG5702	200	250	230
W1G200EG5704	200	250	230
W1G200EG5705	200	250	230
W1G200EC9547	200	250	230
W1G200EC9145	200	250	230
W1G200EC87A2	200	250	230
W1G200EC91A4	200	250	230
W1G200EX9103	200	250	230
W1G200EX8703	200	250	230
W1G200EX9501	200	250	230
W1G200EX9101	200	250	230
W1G200EF4101	200	250	230
W1G200EF0101	200	250	230
W1G200EF6002	200	250	230
W1G230EB9701	230	280	260
W1G230EB8901	230	280	260
W1G250EB2101	250	312.5	285
W1G250EB1701	250	312.5	285

Subject to change.

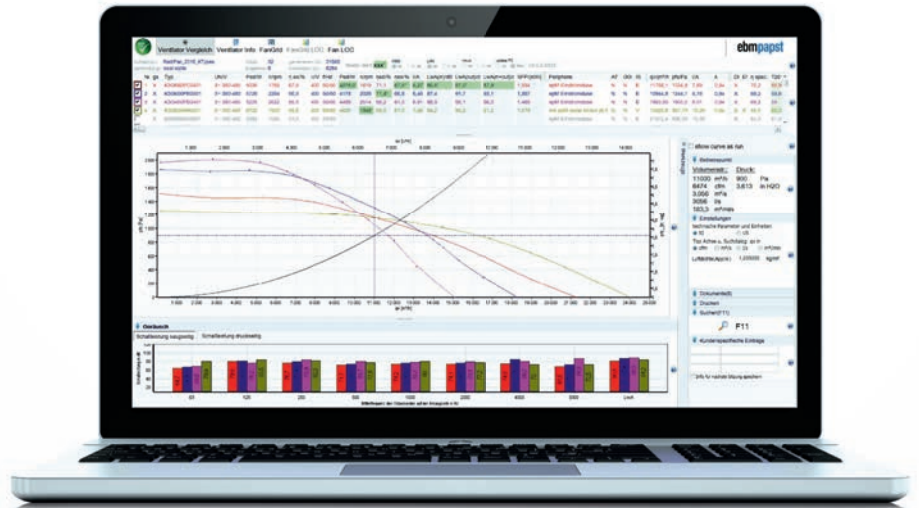

Technology

for refrigerated display cases

ebmpapst

the engineer's choice

	Page
Connection diagrams	108
Technical parameters and scope	120

Connection diagram: ESM1)

Technical features

- Speed selection max/min
- Reverse polarity protection
- Power limiter
- Motor current limitation
- Soft start
- Thermal overload protection for motor
- Speed setting input (230 V)
- Thermal overload protector (TOP) internally connected
- ESM+ expandable with plug-in module

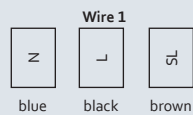

Wire	Designation	Colour	Assignment / function
1	N	blue	Power supply, neutral conductor, see nameplate for voltage range
	L	black	Power supply, phase, see nameplate for voltage range
	SL	brown	Speed selection: switch open speed 1, switch closed speed 2

Connection diagram: ESM2)

Technical features

- Speed setting input
- Speed monitoring Hall IC
- Motor current limitation
- Emergency operation
- RS485 MODBUS-RTU
- Special function automatic speed switching
- Special function automatic speed switching and reversal of rotation
- Thermal overload protection for motor
- Reverse polarity protection
- Thermal overload protector (TOP) internally connected

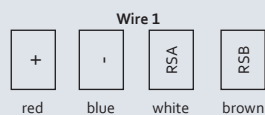

Wire	Designation	Colour	Assignment / function
1	+	red	Power supply, see nameplate for voltage range
	-	blue	Power supply, see nameplate for voltage range
	RSA	white	RS-485 interface for MODBUS RSA/switching input
	RSB	brown	RS-485 interface for MODBUS RSB/switching input

Connection diagram: ESM3)

Technical features

- Tach output
- Motor current limitation
- Soft start
- Control input 0-10 VDC / PWM
- Thermal overload protection for electronics/motor
- Thermal overload protector (TOP) internally connected

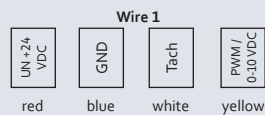

Wire	Designation	Colour	Assignment / function
1	UN +24 VDC	red	Power supply 24 VDC, maximum ripple 3.5 %
	GND	blue	Reference ground
	Tach	white	Tach output, 1 pulse per revolution, Isink max = 10 mA, open collector
	PWM/0-10 VDC	yellow	Control input PWM or 0-10 V, RE > 100k

Connection diagram: ESM4)

Technical features

- Speed setting input (230 V)
- ESM+ expandable with plug-in module
- Soft start
- Thermal overload protection for motor
- Tach output
- Output 10 VDC, max. 1.1 mA
- Thermal overload protector (TOP) internally connected
- Control input 0-10 VDC / PWM

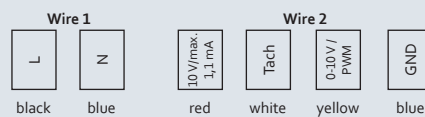

Wire	Designation	Colour	Assignment / function
1	L	black	Power supply, see nameplate for voltage range
	N	blue	Neutral conductor
2	10 V		Voltage output 10 V / 1.1 mA, electrically isolated, not short-circuit-proof
	Tach	white	Tach output: Open collector, 1 pulse per revolution, electrically isolated
	0-10 V / PWM	yellow	Control input 0-10 V or PWM, electrically isolated
	GND	blue	GND connection for control interface

Connection diagram: ESM5)

Technical features

- Speed control via analog voltage (5-10 VDC)
- Locked-rotor protection

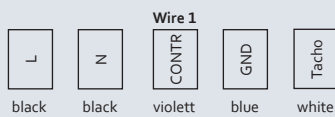

Wire	Designation	Colour	Assignment / function
1	L	black	Power supply
	N	black	Power supply
	CONTR	violett	Speed control
	GND	blue	Weight speed control
	Tacho	white	Tach signal / 2

Connection diagram: ESM6)

Technical features

- Speed control via PWM
- Locked-rotor protection

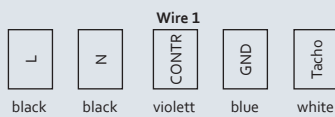

Wire	Designation	Colour	Assignment / function
1	L	black	Power supply
	N	black	Power supply
	CONTR	violett	Speed control
	GND	blue	Weight speed control
	Tacho	white	Tach signal / 2

Connection diagram: ESM7)

Technical features

- Locked-rotor protection

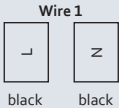

Wire	Designation	Colour	Assignment / function
1	L	black	Power supply
	N	black	Power supply

Connection diagram: ESM8)

Technical features

- Locked-rotor protection
- Reverse polarity protection
- Optionally available with speed control (PWM, analog, temperature, BUS) and output signals (alarm, tach)

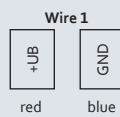

Wire	Designation	Colour	Assignment / function
1	+UB	red	Power supply
	GND	blue	Weight

Connection diagram: iQ1)

Usage

- Standard (constant operating speed)
- ROS (Reverse on Start)

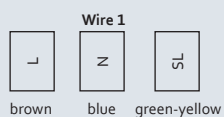

Wire	Designation	Colour	Assignment / function
1	L	brown	Power supply Phase
	N	blue	Power supply Neutral
	SL	green-yellow	Protective earth

Connection diagram: iQ2)

Usage

- 2-speed operation
- ROD (Reverse on Demand)
- Speed control 0-10 VDC

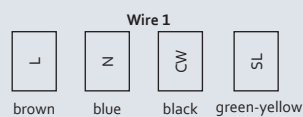

Wire	Designation	Colour	Assignment / function
1	L	brown	Power supply Phase
	N	blue	Power supply Neutral
	CW	black	Control line
	SL	green-yellow	Protective earth

Connection diagram: NiQ1)

Usage

- Standard (constant operating speed)
- ROS (Reverse on Start)

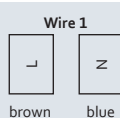

Wire	Designation	Colour	Assignment / function
1	L	brown	Power supply Phase
	N	blue	Power supply Neutral

Connection diagram: NiQ2)

Usage

- 2-speed operation
- ROD (Reverse on Demand)

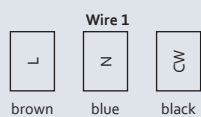

Wire	Designation	Colour	Assignment / function
1	L	brown	Power supply Phase
	N	blue	Power supply Neutral
	CW	black	Control line

Technical parameters and scope

High standards for all ebm-papst products

Here at ebm-papst, we constantly strive to further improve our products in order to be able to offer you the best possible product for your application. Careful monitoring of the market ensures that technical innovations are reflected in the improvements of our products. Based on the technical parameters listed below and the ambience you want our product to operate in, we here at ebm-papst can always work out the best solution for your specific application.

General performance parameters

Any deviations from the technical data and parameters described here are listed on the product-specific data sheet.

Degree of protection

The type of protection is specified in the product-specific data sheets.

Insulation class

The insulation class is specified in the product-specific data sheets.

Installation position

The mounting position is specified in the product-specific data sheets.

Condensate discharge holes

Information on the condensate discharge holes is provided in the product-specific data sheets.

Mode of operation

The mode of operation is specified in the product-specific data sheets.

Protection class

The protection class is specified in the product-specific data sheets.

Service life

The service life of ebm-papst automotive products depends:

– The service life of the bearing system

The service life of the insulation system mainly depends on voltage level, temperature and ambient conditions, such as humidity and condensation.

The service life of the bearing system depends mainly on the thermal load on the bearing.

The majority of our products use maintenance-free ball bearings for any mounting position possible.

The service life L10 of the ball bearings can be taken as approx. 40,000 operating hours at an ambient temperature of 40 °C, yet this estimate can vary according to the actual ambient conditions.

We will gladly provide you with a lifetime calculation taking into account your specific operating conditions.

Motor protection / thermal protection

Information on motor protection and thermal protection is provided in the product-specific data sheets.

Depending on motor type and field of application, the following protective features are realised:

- Thermal overload protector, connected
- PTC/NTC with electronic evaluation
- Current limiting using electronics

Mechanical strain / performance parameters

All ebm-papst products are subjected to comprehensive tests complying with the normative specifications. In addition to this, the tests also reflect the vast experience and expertise of ebm-papst.

High voltage and insulation testing

If high voltage or insulation testing is carried out in the application, then all connection lines from the fan must be disconnected in advance.

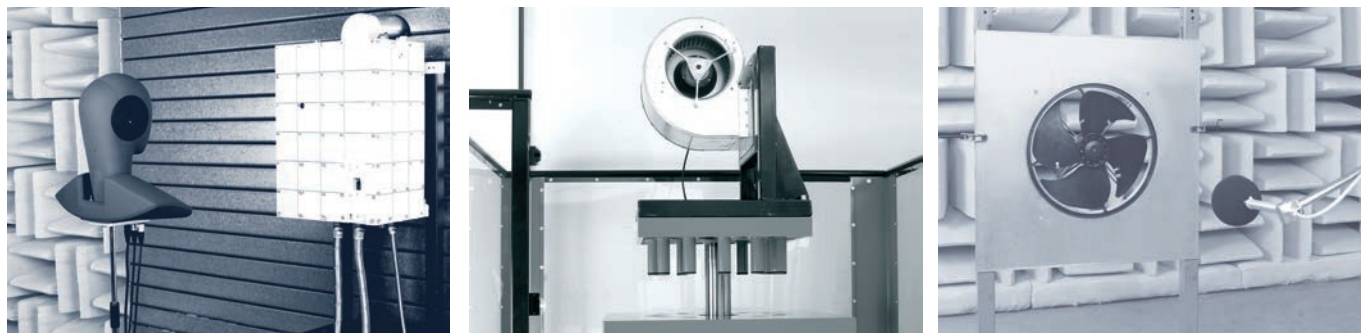

Balancing quality

Testing the balancing quality is carried out in compliance with

- Residual imbalance according to DIN ISO 1940
- Standard balancing quality level G 6.3

Should you require a higher balancing quality level for your specific application, please let us know and specify this when ordering your product.

Chemo-physical strain / performance parameters

Should you have questions about chemo-physical strain, please direct them to your ebm-papst contact.

Fields of application, industries and applications

Our products are used in various industries and applications:

The products in this catalogue have been specifically configured for use in the rail industry!

Legal and normative directives

The products described in this catalogue are designed, developed and produced in keeping with the standards in place for the relevant product and, if known, the conditions governing the relevant fields of application.

Standards

Information on standards is provided in the product-specific data sheets.

EMC

Information on EMC standards is provided in the product-specific data sheets. Complying with the EMC standards has to be established on the final appliance, as different mounting situations can result in changed EMC properties.

Approvals

In case you require a specific approval for your ebm-papst product (e1, UL, etc.) please let us know.

Most of our products can be supplied with the relevant approval.

Information on existing approvals is provided in the product-specific data sheets.

Air performance measurements

All air performance measurements are carried out on suction side and on chamber test beds conforming to the specifications as per ISO 5801 and DIN 24.163. The fans under test are installed in the measuring chamber at free air intake and exhaust (installation category A) and are operated at nominal voltage, with AC also at nominal frequency, and without any additional components such as guard grilles.

As required by the standard, the air performance curves correspond to an air density of 1.15 kg/m³.

Technical parameters and scope

Measurement conditions for air and noise measurement

ebm-papst products are measured under the following conditions:

- Axial and diagonal fans in direction of rotation "V" in full nozzle and without guard grill
- Backward curved centrifugal fans, free-running and with inlet nozzle
- Forward curved single and dual inlet centrifugal fans with housing

Noise measurements

All noise measurements are carried out in low-reflective test rooms with reverberant floor. Thus the ebm-papst acoustic test chambers meet the requirements of precision class 1 according to DIN EN ISO 3745. For noise measurement, the fans being tested are placed in a reverberant wall and operated at nominal voltage (for AC, also at nominal frequency) without additional attachments such as the guard grill.

Sound pressure level and sound level

All acoustic values are established according to ISO 13347, DIN 45635 and ISO 3744/3745 to accuracy class 2 and given in A-rated form.

When the sound pressure level (L_p) is measured, the microphone is on the intake side of the fan being tested, usually at a distance of 1 m on the fan axis.

To measure the sound power level (L_w) 10 microphones are distributed over an enveloping surface on the intake side of the fan being tested (see graphic). The sound power level measured can be roughly calculated from the sound pressure level by adding 7 dB.

Measuring configuration as per ISO 13347-3 bzw. DIN 45635-38:

- 10 measuring points

$$d \geq D$$

$$h = 1.5d \dots 4.5d$$

$$\text{Measurement area } S = 6d^2 + 7d(h + 1.5d)$$

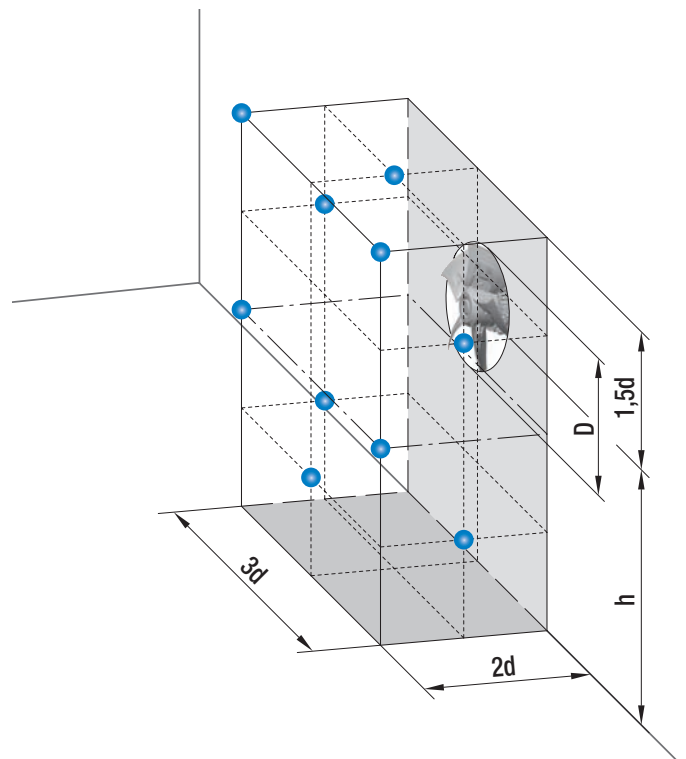

Combined level of multiple same-level sound sources

Adding 2 noise sources with the same level results in a level increase of approx. 3 dB.

The noise characteristics of multiple identical fans can be determined in advance based on the noise values specified in the data sheet. This is shown in the diagram opposite.

Example: 8 A3G800 axial fans are on a condenser. According to the data sheet, the sound pressure level of a fan is approximately 75 dB(A). The level increase measured from the diagram is 9 dB. Thus the overall sound level of the installation can be expected to be 84 dB(A).

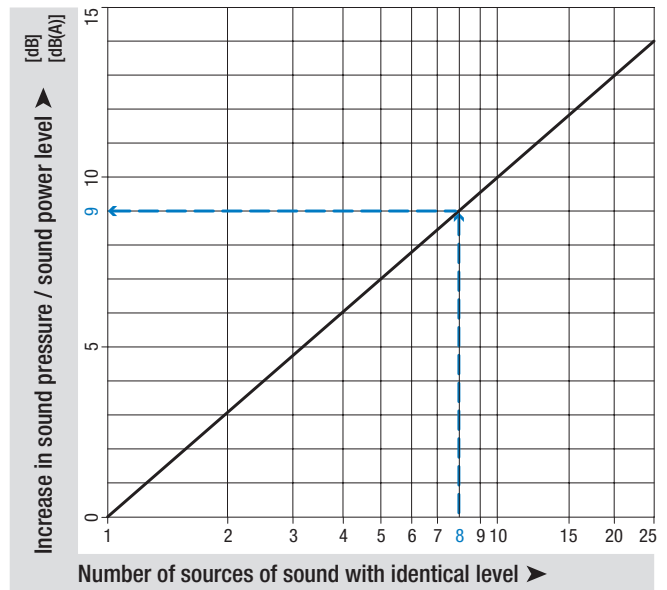

Combined level of two different-level sound sources

The acoustic performance of two different fans can be predetermined based on the sound levels given in the data sheet. This is shown in the diagram opposite.

Example: There is an axial fan A3G800 with a sound pressure level of 75 dB(A) at the operating point and an axial fan A3G710 with 71 dB(A) in a ventilation unit. The level difference is 4 dB. The level increase can now be read in the diagram as approx. 1.5 dB. This means that the overall sound level of the unit can be expected to be 76.5 dB(A).

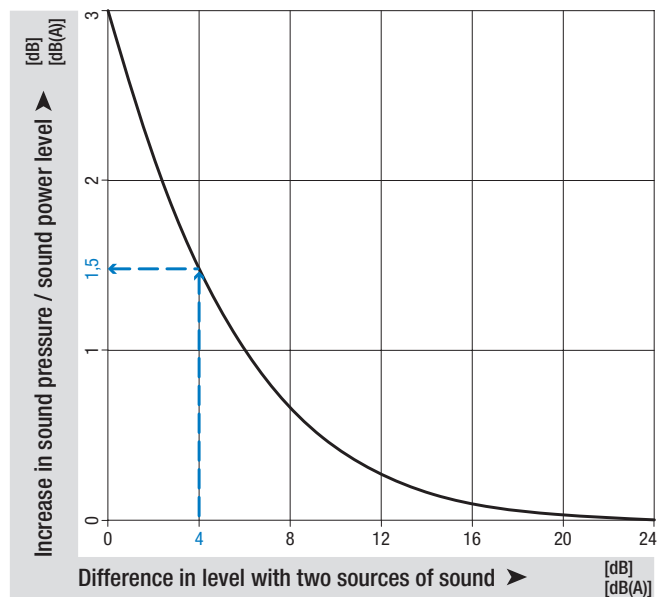

Distance laws

Sound power level is independent of distance to the sound source. In contrast to this, sound pressure level decreases the further away the noise source is. The adjacent diagram shows the decrease in level under far sound field conditions. Far sound field conditions apply whenever the distance between microphone and fan is big when compared to fan diameter and wavelength to be considered. For more information on far sound field, please consult the relevant literature on this complex topic. Per doubling of distance, the level in the far sound field decreases by 6 dB. In the near field of the fan, other correlations apply and the decrease in levels can be considerably smaller. The following example only applies to far sound field conditions and can vary strongly depending on the installation effects: With an axial fan A3G300, a sound pressure level of 65 dB(A) was measured at a distance of 1 m. According to the adjacent diagram, at a distance of 20 m we would get a reduction by 26 dB, i.e. a sound pressure level of 39 dB(A).

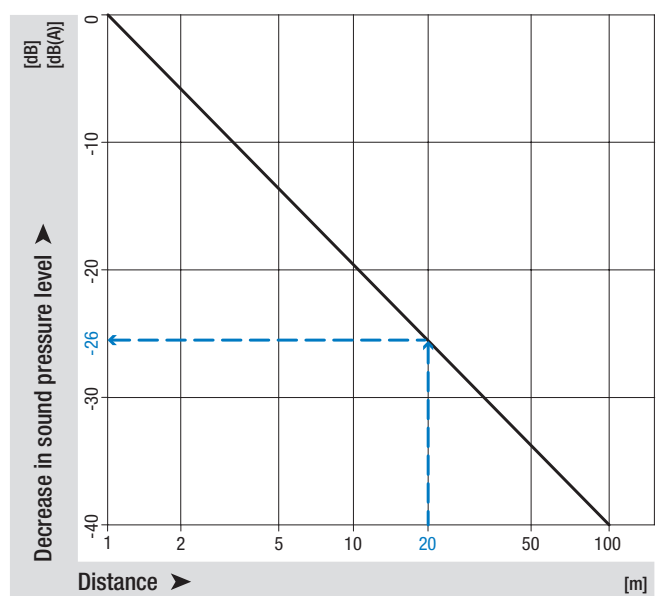

Technical parameters and scope

Aerodynamics fundamentals:

Further information can be found in our brochure "Technology - Basic principles"

Axial fan operating range:

To the right of the saddle point (right section of the air performance curve):

- Maximum efficiency
- Minimum noise

To the left of the saddle point (left section of the air performance curve):

- Stall
- Irruptive efficiency
- Noise suddenly increases

The fan's optimal range of use is highlighted in green in the adjoining performance curve.

Effects of guard grill:

Installing a guard grill reduces the axial fan's air performance.

The pressure loss in Pa can be roughly calculated using the following equation:

$$\Delta p_{SG} = \epsilon_{SG} \cdot 10^{-8} \cdot \dot{V}^2 \quad \dot{V} \text{ in [m}^3/\text{h]}$$

For the guard grill that ebm-papst used, the correction factor ϵ_{SG} dependent on impeller diameter D can be found in the adjoining table.

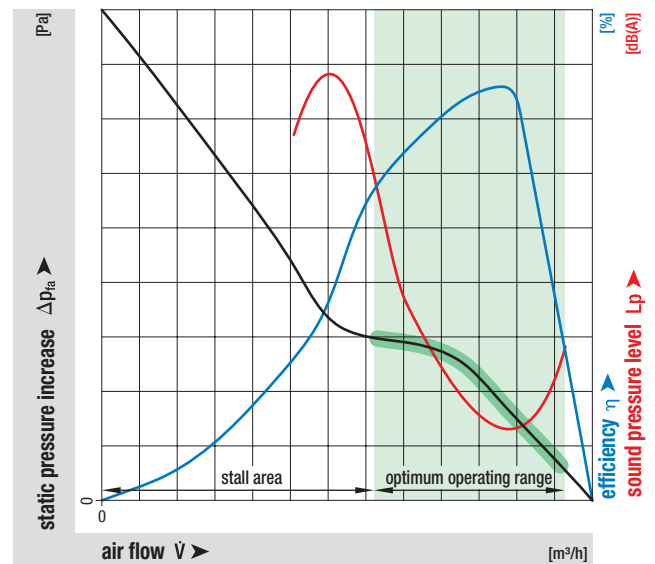

Diameter D	Correction factor ϵ_{SG}
400	90
450	55
500	35

Centrifugal fan operating range:

Middle section of the air performance curve:

- Maximum efficiency
- Minimum noise

To the left and right of the middle section of the air performance curve:

- Reduced efficiency
- Increasing noise

The fan's optimal range of use is highlighted in green in the adjoining performance curve.

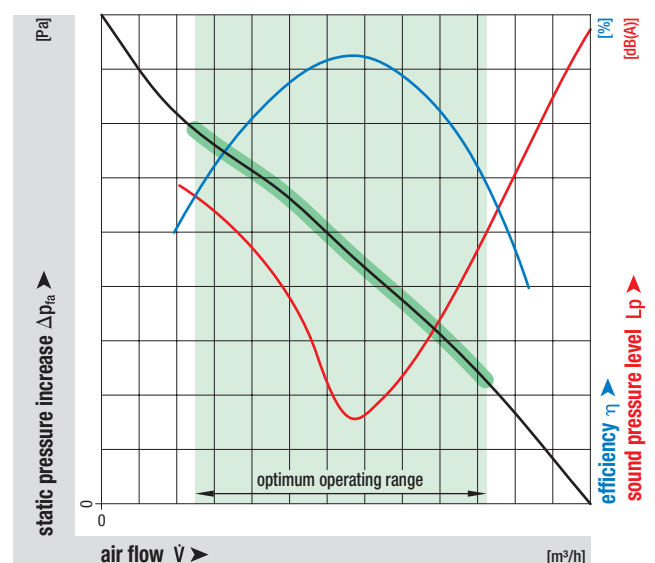

Effects of installation space

Installation in a square box may cause a reduction of the air performance.

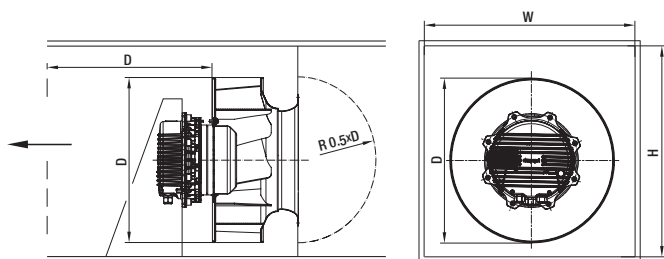

- d_h = hydraulic diameter
Formula: $d_h = 2 \times W \times H / (W + H)$
- W = Width of the box
- H = Height of the box
- D = Outside diameter of the fan

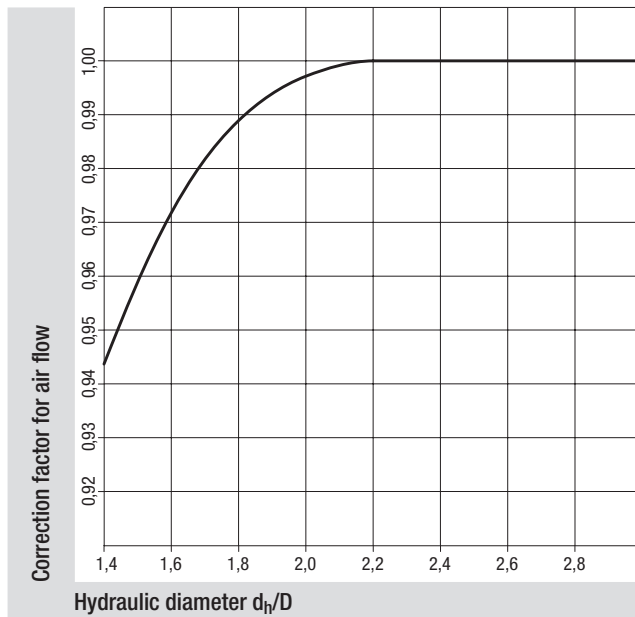

Airflow determination for inlet rings with pressure tap:

The differential pressure method compares the static pressure upstream of the inlet ring with the static pressure in the inlet ring. The airflow can be calculated from the differential pressure (between the static pressures) according to the following equation:

$$q_v = k \cdot \sqrt{\Delta p} \quad q_v \text{ in [m}^3/\text{h] and } \Delta p \text{ in [Pa]}$$

If the airflow is to be regulated to remain constant, the inlet pressure must be kept constant:

$$\Delta p = q_v^2 : k^2$$

k takes the specific properties of the inlet ring into account.

The pressure is tapped at 1 (4) point(s) on the circumference of the inlet ring. The customer connection consists of a built-in T-shaped hose fitting. The hose fitting is suitable for pneumatic hoses with an inside diameter of 4 mm.

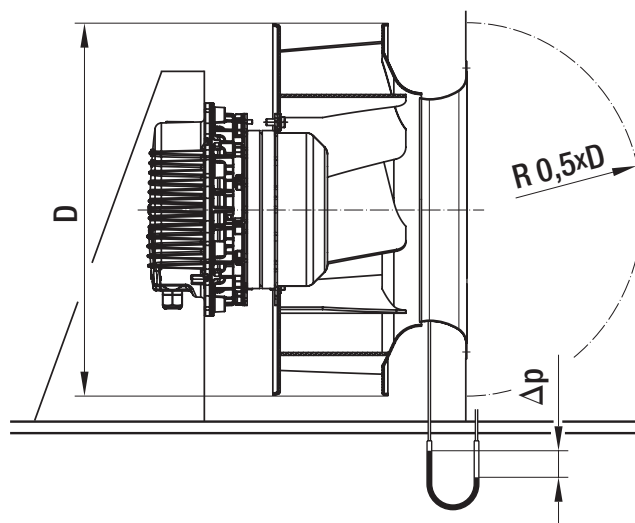

Influence of speed n on the sound power level Lw:

The sound power level for changes in speed can be approximately determined based on the adjoining diagram and the following formula:

$$Lw_2 - Lw_1 = 50 \text{ dB} \cdot \log (n_2 : n_1)$$

- Lw_1 = Sound power level after speed change
- Lw_2 = Sound power level before speed change
- n_1 = Changed speed
- n_2 = Initial speed

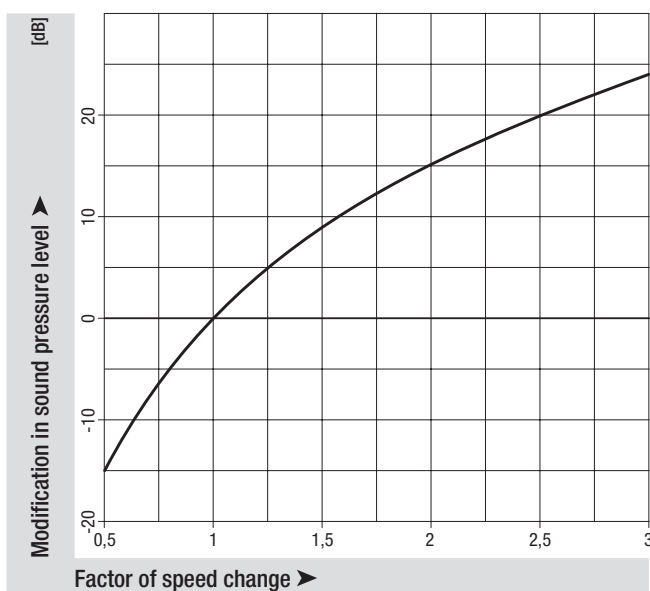

ebm-papst Mulfingen GmbH & Co. KG

Bachmühle 2
74673 Mulfingen
GERMANY
Phone +49 7938 81-0
Fax +49 7938 81-110
info1@de.ebmpapst.com



ebm-papst St. Georgen GmbH & Co. KG

Hermann-Papst-Straße 1
78112 St. Georgen
GERMANY
Phone +49 7724 81-0
Fax +49 7724 81-1309
info2@de.ebmpapst.com



ebm-papst Landshut GmbH

Hofmark-Aich-Straße 25
84030 Landshut
GERMANY
Phone +49 871 707-0
Fax +49 871 707-465
info3@de.ebmpapst.com



Agents

Worldwide

ebmpapst

the engineer's choice

	Page
ebm-papst in Germany	128
ebm-papst in Europe	129
ebm-papst in America and Africa	131
ebm-papst in Asia	132
ebm-papst in Oceania	133

ebm-papst in Germany



Berlin

Dipl.-Ing. (TH) Jens Duchow
Händelstraße 7
16341 Panketal
GERMANY
Phone +49 30 944149-62
Fax +49 30 944149-63
Jens.Duchow@de.ebmpapst.com



Bielefeld

Dipl.-Ing. (FH) Wolf-Jürgen Weber
Niehausweg 13
33739 Bielefeld
GERMANY
Phone +49 5206 91732-31
Fax +49 5206 91732-35
Wolf-Juergen.Weber@de.ebmpapst.com



Dortmund

Dipl.-Ing. (FH) Hans-Joachim Pundt
Auf den Steinern 3
59519 Möhnensee-Völlinghausen
GERMANY
Phone +49 2925 800-407
Fax +49 2925 800-408
Hans-Joachim.Pundt@de.ebmpapst.com



Frankfurt

Dipl.-Ing. Christian Kleffmann
Dr.-Hermann-Krause-Straße 23
63452 Hanau
GERMANY
Phone +49 6181 1898-12
Fax +49 6181 1898-13
Christian.Kleffmann@de.ebmpapst.com



Halle

Dipl.-Ing. (TU) Michael Hanning
Lercheneck 4
06198 Salztal / OT Lieskau
GERMANY
Phone +49 345 55124-56
Fax +49 345 55124-57
Michael.Hanning@de.ebmpapst.com



Hamburg

Ingenieurbüro Breuell GmbH
Ing. Dirk Kahl
Elektroingenieur
Oststraße 96
22844 Norderstedt
GERMANY
Phone +49 40 538092-19
Fax +49 40 538092-84
Kahl@breuell-hilgenfeldt.de



Heilbronn / Heidelberg

Wolfgang Richter
Büttelsbergweg 18
97980 Bad Mergentheim-Rengershausen
GERMANY
Phone +49 7937 32200-33
Fax +49 7938 81-110
Wolfgang.Richter@de.ebmpapst.com



Kassel

Dipl.-Ing. (FH) Ralph Brück
Hoherainstraße 3 b
35075 Gladenbach
GERMANY
Phone +49 6462 4071-10
Fax +49 6462 4071-11
Ralph.Brueck@de.ebmpapst.com



Koblenz

Winfried Schaefer
Hinter der Kirch 10
56767 Uersfeld
GERMANY
Phone +49 2657 16-96
Fax +49 2657 16-76
Winfried.Schaefer@de.ebmpapst.com



Munich

Dipl.-Wirt.-Ing. (FH) Jens Peter
Landsbergerstraße 14
86932 Pürgen
GERMANY
Phone +49 7971 91909-49
Fax +49 8196 99877-55
Jens.Peter@de.ebmpapst.com



Nuremberg

Dipl.-Wirt.-Ing. (FH) Axel Resch
Dr.-August-Koch-Str. 1
91639 Wolframs-Eschenbach
GERMANY
Phone +49 9875 9783-170
Fax +49 9875 9783-171
Axel.Resch@de.ebmpapst.com



Offenburg

Dipl.-Ing. (FH) Ralf Braun
Hubeneck 21
77704 Oberkirch
GERMANY
Phone +49 7802 9822-52
Fax +49 7802 9822-53
Ralf.Braun@de.ebmpapst.com



Stuttgart

Dipl.-Ing. (FH) Rudi Weinmann
Hindenburgstraße 100/1
73207 Plochingen
GERMANY
Phone +49 7153 9289-80
Fax +49 7153 9289-81
Rudi.Weinmann@de.ebmpapst.com



Ulm

M.Sc. Reinhard Sommerreißer
Einsteinstraße 7a
86674 Baar / Schwaben
GERMANY
Phone +49 8276 5899-775
Fax +49 7938 81-110
Reinhard.Sommerreisser@de.ebmpapst.com

Distributors



Frankfurt

R.E.D. Handelsgesellschaft mbH
Gutenbergstraße 3
63110 Rodgau - Jügesheim
GERMANY
Phone +49 6106 841-0
Fax +49 6106 841-111
info@red-elektromechnik.de
www.red-elektromechnik.de



Hamburg

Breuell + Hilgenfeldt GmbH
Oststraße 96
22844 Norderstedt
GERMANY
Phone +49 40 538092-20
Fax +49 40 538092-84
info@breuell-hilgenfeldt.de



Munich

A. Schweiger GmbH
Ohmstraße 1
82054 Sauerlach
GERMANY
Phone +49 8104 897-0
Fax +49 8104 897-90
info@schweiger-gmbh.de
www.schweiger-gmbh.com

● Express Service-Center (1 to 5 pieces)



North

Breuell + Hilgenfeldt GmbH
Oststraße 96
22844 Norderstedt
GERMANY
Phone +49 40 538092-20
Fax +49 40 538092-84
info@breuell-hilgenfeldt.de



South

HDS Ventilatoren Vertriebs GmbH
Glaswiesenstraße 1
74677 Dörzbach
GERMANY
Phone +49 7937 80355-20
Fax +49 7937 80355-25
info@hds-gmbh.net
www.hds-gmbh.net





ebm-papst in Europe



Europe

 **Austria**
ebm-papst Motoren & Ventilatoren GmbH
 Straubingstraße 17
 4030 Linz
AUSTRIA
Phone +43 732 321150-0
Fax +43 732 321150-20
info@at.ebmpapst.com
www.ebmpapst.at

Belarus
ebm-papst Bel AgmbH
 4th Montazhnikov side street
 House 6, Office 332
 BY-220019 Minsk
BELARUS
Phone +375 17 2015216
Fax +375 17 2015216
info@by.ebmpapst.com
www.ebmpapst.by

 **Belgium**
ebm-papst Benelux B.V.
 Sales office Belgium-Luxemburg
 Romeinsestraat 6/0101
Research Park Haasrode
3001 Heverlee-Leuven
BELGIUM
Phone +32 16 396-200
Fax +32 16 396-220
info@be.ebmpapst.com
www.ebmpapst.be

 **Bulgaria**
ebm-papst Romania S.R.L.
 Str. Tarnavei No. 20
 500327 Brasov
ROMANIA
Phone +40 268 331859
Fax +40 268 312805
dudasludovic@xnet.ro

 **Croatia**
ebm-papst Industries Kft.
 Ezred u. 2.
 1044 Budapest
HUNGARY
Phone +36 1 8722-190
Fax +36 1 8722-194
office@hu.ebmpapst.com

 **Cyprus**
Helcoma
 E. Rota and Co. OE
 Davaki 65
17672 Kallithea-Attiki
GREECE
Phone +30 210 9513-705
Fax +30 210 9513-490
contact@helcoma.gr
www.helcoma.gr



 **Czech Republic / Slovakia**
ebm-papst CZ s.r.o.
 Kaštanová 34a
 620 00 Brno
CZECH REPUBLIC
Phone +420 544 502-411
Fax +420 547 232-622
info@ebmpapst.cz
www.ebmpapst.cz



 **Denmark**
ebm-papst Denmark ApS
 Vallensbækvej 21
 2605 Brøndby
DENMARK
Phone +45 43 631111
Fax +45 43 630505
mail@dk.ebmpapst.com
www.ebmpapst.dk

 **Estonia**
ebm-papst Oy, Eesti Filiaal
 Kesk tee 21
 Aaviku küla, Jüri Tehnopark
75301 Rae Vald, Harjumaa
ESTONIA
Phone +372 65569-78
www.ebmpapst.ee



 **Finland**
ebm-papst Oy
 Puistotie 1
 02760 Espoo
FINLAND
Phone +358 9 887022-0
Fax +358 9 887022-13
mailbox@ebmpapst.fi
www.ebmpapst.fi



 **France**
ebm-papst sarl
 Parc d'Activités Nord
 1 rue Mohler – BP 62
67212 Obernai Cedex
FRANCE
Phone +33 3 88 66 88 03
info@ebmpapst.fr
www.ebmpapst.fr

 **Greece**
HELCOMA
 HELLAS IKE
 65, Davaki street
17672 Kallithea-Attiki
GREECE
Phone +30 210 9513-705
Fax +30 210 9513-490
contact@helcoma.gr
www.helcoma.gr

 **Hungary**
ebm-papst Industries Kft.
 Ezred u. 2.
 1044 Budapest
HUNGARY
Phone +36 1 8722-190
Fax +36 1 8722-194
office@hu.ebmpapst.com

 **Iceland**
RJ Engineers
 Stangarhyl 1a
 110 Reykjavik
ICELAND
Phone +354 567 8030
Fax +354 567 8015
rj@rj.is
www.rj.is

 **Ireland**
ebm-papst UK Ltd.
 Chelmsford Business Park
 Chelmsford Essex CM2 5EZ
UNITED KINGDOM
Phone +44 1245 468555
Fax +44 1245 466336
sales@uk.ebmpapst.com
www.ebmpapst.co.uk

 **AuBren Limited**
 Portlaoise Business & Technology Park
 Mountrath Road
Portlaoise, Co. Laois
IRELAND
Phone +353 57 8664343
Fax +353 57 8664346
sales@ie.aubren.com
www.aubren.com

Italy
ebm-papst Srl
Via Cornaggia 108
22076 Mozzate (Co)
ITALY
Phone +39 0331 836201
Fax +39 0331 821510
info@it.ebmpapst.com
www.ebmpapst.it

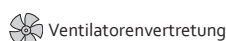

ebm-papst in Europe



Macedonia

ebm-papst Industries Kft.
Ezred u. 2.
1044 Budapest
HUNGARY
Phone +36 1 8722-190
Fax +36 1 8722-194
office@hu.ebmpapst.com



Netherlands

ebm-papst Benelux B.V.
Polbeemd 7 - 5741 TP Beek en Donk
P.O. Box 140 - 5740 AC Beek en Donk
NETHERLANDS
Phone +31 492 502-900
Fax +31 492 502-950
verkoop@nl.ebmpapst.com
www.ebmpapst.nl



ebm-papst Heating Systems B.V.
Van Veldekekade 360
5216 KT 's-Hertogenbosch
NETHERLANDS
Phone +31 73 648 89 00
Fax +31 73 648 89 11
info@ebmpapst-hs.nl
www.ebmpapst-hs.nl



Norway

ebm-papst AS
P.B. 173 Holmlia
1203 Oslo
NORWAY
Phone +47 22 763340
Fax +47 22 619173
mailbox@ebmpapst.no
www.ebmpapst.no



Poland

ebm-papst Polska Sp. z o.o.
ul. Annopol 4A
03236 Warszawa
POLAND
Phone +48 22 6757819
Fax +48 22 6769587
office@ebmpapst.pl
www.ebmpapst.pl



Portugal

ebm-papst (Portugal), Lda.
Centro Empresarial de Alverca
Rua de Adarse, Vale D'Ervas
Corpo D / Fracção 3
2615-178 Alverca do Ribatejo
PORTUGAL
Phone +351 218 394 880
Fax +351 218 394 759
info@pt.ebmpapst.com
www.ebmpapst.pt



Romania

ebm-papst Romania S.R.L.
Str. Tarnavei Nr. 20
500327 Brasov
ROMANIA
Phone +40 268 331859
Fax +40 268 312805
dudasludovic@xnet.ro



Russia

ebm-papst Rus GmbH
Olimpiyskiy prospect 29A, office 418
141006 Mytistschi, Oblast Moskau
RUSSIA
Phone +7 495 9807524
Fax +7 495 5140924
info@ebmpapst.ru
www.ebmpapst.ru



ebm-papst Ural GmbH

Posadskaja-Strasse, 23(E), 3
620102 Ekaterinburg
RUSSIA
Phone +7 343 2338000
Fax +7 343 2337788
Konstantin.Molokov@ru.ebmpapst.com
www.ebmpapst.us



Serbia & Montenegro

ebm-papst Industries Kft.
Ezred u. 2.
1044 Budapest
HUNGARY
Phone +36 1 8722-190
Fax +36 1 8722-194
office@hu.ebmpapst.com



Spain

ebm-papst Ibérica S.L.
Avda. del Sistema Solar, 29
28830 San Fernando de Henares (Madrid)
SPAIN
Phone +34 91 6780894
Fax +34 91 6781530
ventas@ebmpapst.es
www.ebmpapst.es



Sweden

ebm-papst AB
Aggelundavägen 2
17562 Järfälla
SWEDEN
Phone +46 10 4544400
Fax +46 8 362306
info@ebmpapst.se
www.ebmpapst.se



Switzerland

ebm-papst AG
Rütisbergstrasse 1
8156 Oberhasli
SWITZERLAND
Phone +41 44 73220-70
Fax +41 44 73220-77
verkauf@ebmpapst.ch
www.ebmpapst.ch



Turkey

Akantel Elektronik San. Tic. LTD. Sti.
Atatürk Organize Sanayi
Bölgesi 10007 SK. No.:6
35620 Cigli-Izmir
TURKEY
Phone +90 232 3282090
Fax +90 232 3280270
akantel@akantel.com.tr
www.ebmpapst.com.tr



Ukraine

ebm-papst Ukraine LLC
Lepse Boulevard, 4, Building 21
03067 Kiev
UKRAINE
Phone +38 044 2063091
Fax +38 044 2063091
mail@ebmpapst.ua
www.ebmpapst.ua



United Kingdom

ebm-papst UK Ltd.
Chelmsford Business Park
Chelmsford Essex CM2 5EZ
UNITED KINGDOM
Phone +44 1245 468555
Fax +44 1245 466336
sales@uk.ebmpapst.com
www.ebmpapst.co.uk



ebm-papst Automotive & Drives (UK) Ltd.

The Smithy
Fidlers Lane
East Ilsley, Berkshire RG20 7LG
UNITED KINGDOM
Phone +44 1635 2811-11
Fax +44 1635 2811-61
A&Dsales@uk.ebmpapst.com
www.ebmpapst-ad.com



Ventilatorenvertretung



Kompaktlüftervertretung



Motorenspezialist



Motorenvertretung

ebm-papst in America and Africa

America



Argentina

ebm-papst Argentina S.A.
Parque Industrial Canning Etapa II - Nave
61A, Perito Moreno 845, Canning (1804),
Buenos Aires
ARGENTINA
Phone +54 11 46576135
Fax +54 11 46572092
ventas@ar.ebmpapst.com
www.ebmpapst.com.ar



Brazil

ebm-papst Motores Ventiladores Ltda.
Av. José Giorgi, 301 Galpões B6+B7
Condominio Logical Center
06707-100 Cotia - São Paulo
BRAZIL
Phone +55 11 4613-8700
Fax +55 11 4777-1456
vendas@br.ebmpapst.com
www.ebmpapst.com.br



Canada

ebm-papst Canada Inc.
419 King Street West, Suite 603A
Oshawa, ON, L1J2K5
CANADA
Phone +1 905 420-3533
Fax +1 905 420-3772
sales@ca.ebmpapst.com
www.ebmpapst.ca



Mexico

ebm Industrial S. de R.L. de C.V.
Paseo de Tamarindos 400-A-5to Piso
Col. Bosques de las Lomas
Mexico 05120, D.F.
MEXICO
Phone +52 55 3300-5144
Fax +52 55 3300-5243
sales@mx.ebmpapst.com
www.ebmpapst.com.mx

USA



ebm-papst Inc.
P.O. Box 4009
100 Hyde Road
Farmington, CT 06034
UNITED STATES
Phone +1 860 674-1515
Fax +1 860 674-8536
sales@us.ebmpapst.com
www.ebmpapst.us



ebm-papst Inc.
Automotive & Drives Business Unit
3200 Greenfield Road, Suite 130
Dearborn, MI 48120
UNITED STATES
Phone +1 313 406-8080
Fax +1 313 406-8081
automotive@us.ebmpapst.com
www.ebmpapst-automotive.us

Africa



South Africa

ebm-papst South Africa (Pty) Ltd.
P.O. Box 3124
1119 Yacht Avenue
2040 Honeydew
SOUTH AFRICA
Phone +27 11 794-3434
Fax +27 11 794-5020
info@za.ebmpapst.com
www.ebmpapst.co.za



ebm-papst in Asia

Asia



China

ebm-papst Ventilator (Shanghai) Co., Ltd.
No. 418, Huajing Road
WaiGaoQiao Free Trade Zone
No. 2001, Yang Gao (N) Road
200131 Shanghai
P.R. of CHINA
Phone +86 21 5046-0183
Fax +86 21 5046-1119
sales@cn.ebmpapst.com
www.ebmpapst.com.cn



Hong Kong

ebm-papst Hong Kong Ltd.
Room 17E, MG Tower
133 Hoi Bun Road, Kwun Tong
Hong Kong
P.R. of CHINA
Phone +852 2145-8678
Fax +852 2145-7678
info@hk.ebmpapst.com



India

ebm-papst India Pvt. Ltd.
26/3, G.N.T. Road, Erukkencherry
Chennai-600118
INDIA
Phone +91 44 25372556
Fax +91 44 25371149
sales@in.ebmpapst.com
www.ebmpapst.in



Indonesia

ebm-papst SEA Pte. Ltd.
Representative Office - Indonesia
Graha Telkomsigma, 4th Floor, Suite 4470
Jl. Kapt. Subijono Dj. Bumi Serpong Damai
15321 Tangerang
INDONESIA
Phone +62 21 5376250-52
Fax +62 21 5388305
sales@id.ebmpapst.com



Israel

Polak Bros. Import Agencies Ltd.
9 Hamefalsim Street
Kiryat Arie, Petach-Tikva 49514
ISRAEL
Phone +972 3 9100300
Fax +972 3 5796679
polak@polak.co.il
www.polak.co.il



Japan

ebm-papst Japan K.K.
Attend on Tower 13F
Shinyokohama 2-8-12, Kohoku-ku
222-0033 Yokohama-City, Kanagawa
JAPAN
Phone +81 45 47057-51
Fax +81 45 47057-52
info@jp.ebmpapst.com
www.ebmpapst.jp



Korea

ebm-papst Korea Co. Ltd.
A-13F, Doosan The Land Tower
152, Magokseo-ro
Gangseo-gu
Seoul 07788
KOREA
Phone +82 2 366213-24
Fax +82 2 366213-26
info@kr.ebmpapst.com
www.ebmpapst.co.kr



Malaysia

ebm-papst SEA Pte. Ltd.
Representative Office - Malaysia
No. 16-1, Jalan Putra Mahkota 7/5A
Putra Heights
Selangor Darul Ehsan
47650 Subang Jaya
MALAYSIA
Phone +60 3 5192-7688
Fax +60 3 5614-3078
sales@my.ebmpapst.com



Philippines

ebm-papst SEA Pte. Ltd.
Representative Office - Philippines
Coherco Financial Tower
Trade Street Corner Investment Drive
Unit 1101 Madrigal Business Park
Ayala Alabang / Muntinlupa City
Phone: +63 02 8042747
Fax: +63 02 8042757
sales@ph.ebmpapst.com



Singapore

ebm-papst SEA Pte. Ltd.
10 Changi South Street 2
#01-01/02
Singapore 486596
SINGAPORE
Phone +65 65513789
Fax +65 68428439
sales@sg.ebmpapst.com



Taiwan

ETECO Engineering & Trading Corp.
10F-I, No. 92, Teh-Wei Str.
Tso-wann District, Kaohsiung
TAIWAN
Phone +886 7 557-4268
Fax +886 7 557-2788
eteco@ms22.hinet.net
www.ebmpapst.com.tw



Thailand

ebm-papst Thailand Co., Ltd.
99/9 Moo 2, Central Chaengwattana Tower
8th Floor, Room 801-802
Chaengwattana Road Bangtarad, Pakkret
11120 Nonthaburi
THAILAND
Phone +66 2 8353785-7
Fax +66 2 8353788
sales@th.ebmpapst.com



United Arab Emirates

ebm-papst Middle East FZE
PO Box 17755
Jebel Ali Free Zone / FZS1 / AP05
Dubai
UNITED ARAB EMIRATES
Phone +971 4 88608-26
Fax +971 4 88608-27
info@ae.ebmpapst.com
www.ebmpapst.ae



Vietnam

ebm-papst SEA Pte. Ltd.
Representative Office - Vietnam
Floor M, Phuong Long Building,
506 Nguyen Dinh Chieu Street,
Ward 4, District 3,
Ho Chi Minh City
VIETNAM
Phone +84 28 3929 0699
Fax +84 28 3929 0669
sales@vn.ebmpapst.com



Ventilatorenvertretung



Kompaktlüftervertretung



Motorenspezialist



Motorenvertretung

ebm-papst in Oceania

Oceania



Australia

ebm-papst A&NZ Pty Ltd.
10 Oxford Road
Laverton North, Victoria, 3026
AUSTRALIA
Phone +61 3 9360-6400
Fax +61 3 9360-6464
sales@ebmpapst.com.au
www.ebmpapst.com.au



New Zealand

ebm-papst A&NZ Pty Ltd.
61 Hugo Johnston Drive, Unit H
Penrose 1061, Auckland
NEW ZEALAND
PO Box 112278,
Penrose 1642, Auckland
Phone +64 9 525-0245
Fax +64 9 525-0246
sales@ebmpapst.com.au
www.ebmpapst.com.au



Ventilatorenvertretung



Kompaktlüftervertretung



Motorenspezialist



Motorenvertretung

Notes

Notes

ebmpapst

the engineer's choice



ebm-papst
Mulfingen GmbH & Co. KG

Bachmühle 2
74673 Mulfingen
Germany
Phone +49 7938 81-0
Fax +49 7938 81-110
info1@de.ebmpapst.com

ebm-papst
St. Georgen GmbH & Co. KG

Hermann-Papst-Straße 1
78112 St. Georgen
Germany
Phone +49 7724 81-0
Fax +49 7724 81-1309
info2@de.ebmpapst.com

ebm-papst
Landshut GmbH

Hofmark-Aich-Straße 25
84030 Landshut
Germany
Phone +49 871 707-0
Fax +49 871 707-465
info3@de.ebmpapst.com

Mouser Electronics

Authorized Distributor

Click to View Pricing, Inventory, Delivery & Lifecycle Information:

[ebm-papst:](#)

[4312NMU](#) [4314NMU](#)